



SiUS39 - 601

# Service Manual



## RXYQ72, 96, 144, 168, 192MTJU R-410A Heat Pump 60Hz



RXYQ72MTJU RXYQ96MTJU

RXYQ144MTJU

RXYQ168MTJU

RXYQ192MTJU

# **VRV<sup>®</sup> R-410A Heat Pump 60Hz**

|  |           |
|--|-----------|
| 1. Introduction .....                            | vi        |
| 1.1 Safety Cautions .....                        | vi        |
| 1.2 PREFACE .....                                | x         |
| <b>Part 1 General Information .....</b>          | <b>1</b>  |
| 1. Model Names of Indoor/Outdoor Units.....      | 2         |
| 2. External Appearance.....                      | 3         |
| 2.1 Indoor Units .....                           | 3         |
| 2.2 Outdoor Units .....                          | 3         |
| 3. Model Selection.....                          | 4         |
| <b>Part 2 Specifications .....</b>               | <b>5</b>  |
| 1. Specifications .....                          | 6         |
| 1.1 Outdoor Units .....                          | 6         |
| 1.2 Indoor Units .....                           | 11        |
| <b>Part 3 Refrigerant Circuit .....</b>          | <b>23</b> |
| 1. Refrigerant Circuit .....                     | 24        |
| 1.1 RXYQ72M, 96M .....                           | 24        |
| 2. Functional Parts Layout .....                 | 26        |
| 2.1 RXYQ72M, 96M .....                           | 26        |
| 3. Refrigerant Flow for Each Operation Mode..... | 27        |
| <b>Part 4 Function.....</b>                      | <b>31</b> |
| 1. Operation Mode .....                          | 32        |
| 2. Basic Control.....                            | 33        |
| 2.1 Normal Operation .....                       | 33        |
| 2.2 Compressor PI Control.....                   | 34        |
| 2.3 Electronic Expansion Valve PI Control.....   | 38        |
| 2.4 Cooling Operation Fan Control.....           | 39        |
| 3. Special Control.....                          | 40        |
| 3.1 Startup Control .....                        | 40        |
| 3.2 Oil Return Operation .....                   | 41        |
| 3.3 Defrosting Operation .....                   | 43        |
| 3.4 Pump-down Residual Operation .....           | 44        |
| 3.5 Restart Standby.....                         | 45        |
| 3.6 Stopping Operation .....                     | 46        |

|     |  |    |
|-----|--|----|
| 3.7 | Pressure Equalization prior to Startup | 48 |
| 4.  | Protection Control                     | 49 |
| 4.1 | High Pressure Protection Control       | 49 |
| 4.2 | Low Pressure Protection Control        | 50 |
| 4.3 | Discharge Pipe Protection Control      | 51 |
| 4.4 | Inverter Protection Control            | 52 |
| 4.5 | STD Compressor Overload Protection     | 53 |
| 5.  | Other Control                          | 54 |
| 5.1 | Outdoor Unit Rotation                  | 54 |
| 5.2 | Emergency Operation                    | 55 |
| 5.3 | Demand Operation                       | 57 |
| 5.4 | Heating Operation Prohibition          | 57 |
| 6.  | Outline of Control (Indoor Unit)       | 58 |
| 6.1 | Drain Pump Control                     | 58 |
| 6.2 | Thermostat Sensor in Remote Controller | 60 |
| 6.3 | Freeze Prevention                      | 62 |

## **Part 5 Test Operation ..... 63**

|     |                                      |    |
|-----|--------------------------------------|----|
| 1.  | Test Operation                       | 64 |
| 1.1 | Procedure and Outline                | 64 |
| 1.2 | Operation When Power is Turned On    | 67 |
| 2.  | Outdoor Unit PC Board Layout         | 68 |
| 3.  | Field Setting                        | 69 |
| 3.1 | Field Setting from Remote Controller | 69 |
| 3.2 | Field Setting from Outdoor Unit      | 81 |

## **Part 6 Troubleshooting ..... 105**

|     |   |     |
|-----|---|-----|
| 1.  | Troubleshooting by Remote Controller  | 108 |
| 1.1 | The INSPECTION / TEST Button  | 108 |
| 1.2 | Self-diagnosis by Wired Remote Controller   | 109 |
| 1.3 | Self-diagnosis by Wireless Remote Controller  | 110 |
| 1.4 | Operation of The Remote Controller's Inspection /<br>Test Operation Button          | 112 |
| 1.5 | Remote Controller Service Mode  | 113 |
| 1.6 | Remote Controller Self-Diagnosis Function   | 115 |
| 2.  | Troubleshooting by Indication on the Remote Controller                              | 120 |
| 2.1 | "R0" Indoor Unit: Error of External Protection Device                               | 120 |
| 2.2 | "R1" Indoor Unit: PC Board Defect   | 121 |
| 2.3 | "R3" Indoor Unit: Malfunction of Drain Level Control System (S1L)                   | 122 |
| 2.4 | "R5" Indoor Unit: Fan Motor (M1F) Lock, Overload                                    | 124 |
| 2.5 | "R7" Indoor Unit: Malfunction of Swing Flap Motor (MA)                              | 125 |
| 2.6 | "R9" Indoor Unit: Malfunction of Moving Part of<br>Electronic Expansion Valve (20E) | 127 |
| 2.7 | "RF" Indoor Unit: Drain Level above Limit   | 129 |
| 2.8 | "RU" Indoor Unit: Malfunction of Capacity Determination Device                      | 130 |
| 2.9 | "C4" Indoor Unit: Malfunction of Thermistor (R2T) for Heat Exchanger                | 131 |

|      |  |     |
|------|--|-----|
| 2.10 | “C5” Indoor Unit: Malfunction of Thermistor (R3T) for Gas Pipes.....   | 132 |
| 2.11 | “C9” Indoor Unit: Malfunction of Thermistor (R1T) for Suction Air.....   | 133 |
| 2.12 | “CU” Indoor Unit: Malfunction of Thermostat Sensor<br>in Remote Controller .....                                 | 134 |
| 2.13 | “E1” Outdoor Unit: PC Board Defect .....   | 135 |
| 2.14 | “E3” Outdoor Unit: Actuation of High Pressure Switch .....   | 136 |
| 2.15 | “E4” Outdoor Unit: Actuation of Low Pressure Sensor .....  | 137 |
| 2.16 | “E5” Compressor Motor Lock .....   | 139 |
| 2.17 | “E6” Compressor Motor Overcurrent/Lock .....   | 141 |
| 2.18 | “E7” Malfunction of Outdoor Unit Fan Motor .....   | 142 |
| 2.19 | “E9” Outdoor Unit: Malfunction of Moving Part<br>of Electronic Expansion Valve (Y1E, Y2E).....                   | 144 |
| 2.20 | “F3” Outdoor Unit: Abnormal Discharge Pipe Temperature .....   | 146 |
| 2.21 | “F6” Refrigerant Overcharged .....   | 147 |
| 2.22 | “H7” Abnormal Outdoor Fan Motor Signal .....   | 148 |
| 2.23 | “H9” Outdoor Unit: Malfunction of Thermistor (R1T) for Outdoor Air.....  | 150 |
| 2.24 | “J2” Current Sensor Malfunction .....  | 151 |
| 2.25 | “J3” Outdoor Unit: Malfunction of Discharge<br>Pipe Thermistor (R31~33T).....                                    | 152 |
| 2.26 | “J5” Outdoor Unit: Malfunction of Thermistor (R2T) for Suction Pipe .....  | 153 |
| 2.27 | “J6” Outdoor Unit: Malfunction of Thermistor (R4T)<br>for Outdoor Unit Heat Exchanger Deicer.....                | 154 |
| 2.28 | “J7” Malfunction of Receiver Outlet Liquid Pipe<br>Thermistor (R6T) .....  | 155 |
| 2.29 | “J8” Malfunction of Oil Equalizing Pipe Thermistor (R7T).....  | 156 |
| 2.30 | “J9” Malfunction of Sub-Cooling Gas Pipe Thermistor (R5T) .....  | 157 |
| 2.31 | “JR” Outdoor Unit: Malfunction of Discharge Pipe Pressure Sensor.....  | 158 |
| 2.32 | “JL” Outdoor Unit: Malfunction of Suction Pipe Pressure Sensor .....   | 160 |
| 2.33 | “L4” Outdoor Unit: Malfunction of Inverter Radiating<br>Fin Temperature Rise.....                                | 161 |
| 2.34 | “L5” Outdoor Unit: Inverter Compressor Abnormal .....  | 162 |
| 2.35 | “LB” Outdoor Unit: Inverter Current Abnormal.....  | 163 |
| 2.36 | “L9” Outdoor Unit: Inverter Start up Error.....  | 165 |
| 2.37 | “LC” Outdoor Unit: Malfunction of Transmission Between Inverter<br>and Control PC Board .....                    | 166 |
| 2.38 | “PP” Outdoor Unit: Inverter Over-Ripple Protection .....   | 168 |
| 2.39 | “P4” Outdoor Unit: Malfunction of Inverter Radiating<br>Fin Temperature Rise Sensor .....                        | 170 |
| 2.40 | “PJ” Outdoor Unit: Faulty Field Setting after Replacing Main<br>PC Board or Faulty Combination of PC Board ..... | 171 |
| 2.41 | “UD” Outdoor Unit: Low Pressure Drop Due to Refrigerant Shortage<br>or Electronic Expansion Valve Failure.....   | 172 |
| 2.42 | “U7” Outdoor Unit: Reverse Phase, Open Phase .....   | 174 |
| 2.43 | “U2” Outdoor Unit: Power Supply Insufficient<br>or Instantaneous Failure.....                                    | 175 |
| 2.44 | “U3” Outdoor Unit: Check Operation not executed.....   | 177 |
| 2.45 | “U4” Malfunction of Transmission Between Indoor Units<br>and Outdoor Units .....                                 | 178 |

|      |   |     |
|------|---|-----|
| 2.46 | “U5” Indoor Unit: Malfunction of Transmission Between Remote Controller and Indoor Unit.....                  | 180 |
| 2.47 | “U7” Indoor Unit: Malfunction of Transmission Between Outdoor Units .....                                     | 181 |
| 2.48 | “U8” Indoor Unit: Malfunction of Transmission Between Main and Sub Remote Controllers .....                   | 183 |
| 2.49 | “U9” Indoor Unit: Malfunction of Transmission Between Indoor Units and Outdoor Units in the Same System ..... | 184 |
| 2.50 | “UR” Improper Combination of Indoor Units and Outdoor Units/Indoor Units and Remote Controller.....           | 186 |
| 2.51 | “UC” Address Duplication of Central Remote Controller.....  | 188 |
| 2.52 | “UE” Malfunction of Transmission Between Centralized Controller and Indoor Unit.....                          | 189 |
| 2.53 | “UF” System is not Set yet.....   | 191 |
| 2.54 | “UH” Malfunction of System, Refrigerant System Address Undefined.....   | 192 |
| 3.   | Troubleshooting (OP: Central Remote Controller) .....   | 194 |
| 3.1  | “M1” PC Board Defect .....  | 194 |
| 3.2  | “M8” Malfunction of Transmission Between Optional Controllers for Centralized Control .....                   | 195 |
| 3.3  | “MR” Improper Combination of Optional Controllers for Centralized Control .....                               | 197 |
| 3.4  | “MC” Address Duplication, Improper Setting .....  | 199 |
| 4.   | Troubleshooting (OP: Schedule Timer).....   | 200 |
| 4.1  | “UE” Malfunction of Transmission Between Central Remote Controller and Indoor Unit.....                       | 200 |
| 4.2  | “M1” PC Board Defect .....  | 202 |
| 4.3  | “M8” Malfunction of Transmission Between Optional Controllers for Centralized Control .....                   | 203 |
| 4.4  | “MR” Improper Combination of Optional Controllers for Centralized Control .....                               | 205 |
| 4.5  | “MC” Address Duplication, Improper Setting .....  | 207 |
| 5.   | Troubleshooting (OP: Unified ON/OFF Controller) .....   | 208 |
| 5.1  | Operation Lamp Blinks.....  | 208 |
| 5.2  | Display “Under Centralized Control” Blinks (Repeats Single Blink) .....                                       | 210 |
| 5.3  | Display “Under Centralized Control” Blinks (Repeats Double Blink) .....                                       | 213 |

## **Part 7 Replacement Procedure for INV Compressor, VRV ..... 217**

|     |  |     |
|-----|--|-----|
| 1.  | Replacement Procedure for INV Compressor, VRV (RXYQ72M, 96M) ..... | 218 |
| 1.1 | Replacement Procedure.....   | 218 |

## **Part 8 Appendix..... 219**







|     |                      |     |
|-----|----------------------|-----|
| 1.  | Piping Diagrams..... | 220 |
| 1.1 | Outdoor Unit.....    | 220 |
| 1.2 | Indoor Unit.....     | 221 |

|   |            |
|---|------------|
| 2. Wiring Diagrams for Reference .....  | 223        |
| 2.1 Outdoor Unit .....  | 223        |
| 2.2 Field Wiring .....  | 224        |
| 2.3 Indoor Unit .....   | 226        |
| 3. List of Electrical and Functional Parts .....                                    | 230        |
| 3.1 Outdoor Unit .....  | 230        |
| 3.2 Indoor Side .....   | 231        |
| 4. Option List .....  | 235        |
| 4.1 Option List of Controllers .....  | 235        |
| 4.2 Option Lists (Outdoor Unit) .....   | 236        |
| 5. Example of Connection .....  | 237        |
| 6. Thermistor Resistance / Temperature Characteristics .....                        | 239        |
| 7. Pressure Sensor .....  | 241        |
| 8. Method of Replacing The Inverter's Power Transistors<br>and Diode Modules .....  | 242        |
| 8.1 Method of Replacing The Inverter's Power Transistors<br>and Diode Modules ..... | 242        |
| <b>Part 9 Precautions for New Refrigerant (R-410A) .....</b>                        | <b>245</b> |
| 1. Precautions for New Refrigerant (R-410A) .....                                   | 246        |
| 1.1 Outline .....   | 246        |
| 1.2 Service Tools .....   | 248        |
| <b>Index .....</b>  | <b>i</b>   |
| <b>Drawings &amp; Flow Charts .....</b>   | <b>v</b>   |







# 1. Introduction







## 1.1 Safety Cautions

### Cautions and Warnings

- Be sure to read the following safety cautions before conducting repair work.
- The caution items are classified into “ **Warning**” and “ **Caution**”. The “ **Warning**” items are especially important since they can lead to death or serious injury if they are not followed closely. The “ **Caution**” items can also lead to serious accidents under some conditions if they are not followed. Therefore, be sure to observe all the safety caution items described below.
- About the pictograms
  -  This symbol indicates an item for which caution must be exercised.  
The pictogram shows the item to which attention must be paid.
  -  This symbol indicates a prohibited action.  
The prohibited item or action is shown inside or near the symbol.
  -  This symbol indicates an action that must be taken, or an instruction.  
The instruction is shown inside or near the symbol.
- After the repair work is complete, be sure to conduct a test operation to ensure that the equipment operates normally, and explain the cautions for operating the product to the customer

### 1.1.1 Caution in Repair



|  <b>Warning</b>  |   |
|---|---|
| Be sure to disconnect the power cable plug from the plug socket before disassembling the equipment for a repair.<br>Working on the equipment that is connected to a power supply can cause an electrical shock.<br>If it is necessary to supply power to the equipment to conduct the repair or inspecting the circuits, do not touch any electrically charged sections of the equipment. |   |
| If the refrigerant gas discharges during the repair work, do not touch the discharging refrigerant gas.<br>The refrigerant gas can cause frostbite.   |  |
| When disconnecting the suction or discharge pipe of the compressor at the welded section, release the refrigerant gas completely at a well-ventilated place first.<br>If there is a gas remaining inside the compressor, the refrigerant gas or refrigerating machine oil discharges when the pipe is disconnected, and it can cause injury.  |   |
| If the refrigerant gas leaks during the repair work, ventilate the area. The refrigerant gas can generate toxic gases when it contacts flames.  |  |
| The step-up capacitor supplies high-voltage electricity to the electrical components of the outdoor unit.<br>Be sure to discharge the capacitor completely before conducting repair work.<br>A charged capacitor can cause an electrical shock.   |  |
| Do not start or stop the air conditioner operation by plugging or unplugging the power cable plug.<br>Plugging or unplugging the power cable plug to operate the equipment can cause an electrical shock or fire.   |  |



|  <b>Caution</b>  |   |
|---|---|
| Do not repair the electrical components with wet hands.<br>Working on the equipment with wet hands can cause an electrical shock.   |    |
| Do not clean the air conditioner by splashing water.<br>Washing the unit with water can cause an electrical shock.  |    |
| Be sure to provide the grounding when repairing the equipment in a humid or wet place, to avoid electrical shocks.  |    |
| Be sure to turn off the power switch and unplug the power cable when cleaning the equipment.<br>The internal fan rotates at a high speed, and cause injury.   |    |
| Do not tilt the unit when removing it.<br>The water inside the unit can spill and wet the furniture and floor.  |  |
| Be sure to check that the refrigerating cycle section has cooled down sufficiently before conducting repair work.<br>Working on the unit when the refrigerating cycle section is hot can cause burns. |   |
| Use the welder in a well-ventilated place.<br>Using the welder in an enclosed room can cause oxygen deficiency.   |  |

### 1.1.2 Cautions Regarding Products after Repair



|  <b>Warning</b>   |                         |
|--|-------------------------|
| Be sure to use parts listed in the service parts list of the applicable model and appropriate tools to conduct repair work. Never attempt to modify the equipment. The use of inappropriate parts or tools can cause an electrical shock, excessive heat generation or fire.                             |                         |
| When relocating the equipment, make sure that the new installation site has sufficient strength to withstand the weight of the equipment.<br>If the installation site does not have sufficient strength and if the installation work is not conducted securely, the equipment can fall and cause injury. |                         |
| Be sure to install the product correctly by using the provided standard installation frame.<br>Incorrect use of the installation frame and improper installation can cause the equipment to fall, resulting in injury.   | For integral units only |
| Be sure to install the product securely in the installation frame mounted on a window frame.<br>If the unit is not securely mounted, it can fall and cause injury.   | For integral units only |







|  <b>Warning</b>   |  |
|--|--|
| Be sure to use an exclusive power circuit for the equipment, and follow the technical standards related to the electrical equipment, the internal wiring regulations and the instruction manual for installation when conducting electrical work.<br>Insufficient power circuit capacity and improper electrical work can cause an electrical shock or fire.   |  |
| Be sure to use the specified cable to connect between the indoor and outdoor units. Make the connections securely and route the cable properly so that there is no force pulling the cable at the connection terminals.<br>Improper connections can cause excessive heat generation or fire.   |  |
| When connecting the cable between the indoor and outdoor units, make sure that the terminal cover does not lift off or dismount because of the cable.<br>If the cover is not mounted properly, the terminal connection section can cause an electrical shock, excessive heat generation or fire.   |  |
| Do not damage or modify the power cable.<br>Damaged or modified power cable can cause an electrical shock or fire.<br>Placing heavy items on the power cable, and heating or pulling the power cable can damage the cable.   |   |
| Do not mix air or gas other than the specified refrigerant (R-410A) in the refrigerant system.<br>If air enters the refrigerating system, an excessively high pressure results, causing equipment damage and injury.   |  |
| If the refrigerant gas leaks, be sure to locate the leak and repair it before charging the refrigerant. After charging refrigerant, make sure that there is no refrigerant leak.<br>If the leak cannot be located and the repair work must be stopped, be sure to perform pump-down and close the service valve, to prevent the refrigerant gas from leaking into the room. The refrigerant gas itself is harmless, but it can generate toxic gases when it contacts flames, such as fan and other heaters, stoves and ranges. |  |
| When replacing the coin battery in the remote controller, be sure to disposed of the old battery to prevent children from swallowing it.<br>If a child swallows the coin battery, see a doctor immediately.  |  |

|  <b>Caution</b>   |   |
|--|---|
| Installation of a leakage breaker is necessary in some cases depending on the conditions of the installation site, to prevent electrical shocks.   |   |
| Do not install the equipment in a place where there is a possibility of combustible gas leaks.<br>If a combustible gas leaks and remains around the unit, it can cause a fire.               |  |
| Be sure to install the packing and seal on the installation frame properly.<br>If the packing and seal are not installed properly, water can enter the room and wet the furniture and floor. | For integral units only   |

### 1.1.3 Inspection after Repair

|  <b>Warning</b>   |   |
|--|---|
| Check to make sure that the power cable plug is not dirty or loose, then insert the plug into a power outlet all the way.<br>If the plug has dust or loose connection, it can cause an electrical shock or fire. |  |





|  <b>Warning</b>  |   |
|---|---|
| If the power cable and lead wires have scratches or deteriorated, be sure to replace them.<br>Damaged cable and wires can cause an electrical shock, excessive heat generation or fire.         |  |
| Do not use a joined power cable or extension cable, or share the same power outlet with other electrical appliances, since it can cause an electrical shock, excessive heat generation or fire. |  |

|  <b>Caution</b>   |  |
|--|--|
| Check to see if the parts and wires are mounted and connected properly, and if the connections at the soldered or crimped terminals are secure.<br>Improper installation and connections can cause excessive heat generation, fire or an electrical shock. |  |
| If the installation platform or frame has corroded, replace it.<br>Corroded installation platform or frame can cause the unit to fall, resulting in injury.  |  |
| Check the grounding, and repair it if the equipment is not properly grounded.<br>Improper grounding can cause an electrical shock.   |  |
| Be sure to measure the insulation resistance after the repair, and make sure that the resistance is 1 Mohm or higher.<br>Faulty insulation can cause an electrical shock.  |  |
| Be sure to check the drainage of the indoor unit after the repair.<br>Faulty drainage can cause the water to enter the room and wet the furniture and floor.   |  |

### 1.1.4 Using Icons

Icons are used to attract the attention of the reader to specific information. The meaning of each icon is described in the table below:

### 1.1.5 Using Icons List

| Icon  | Type of Information | Description  |
|---|---------------------|--|
|  Note:   | Note                | A “note” provides information that is not indispensable, but may nevertheless be valuable to the reader, such as tips and tricks.  |
|  Caution | Caution             | A “caution” is used when there is danger that the reader, through incorrect manipulation, may damage equipment, lose data, get an unexpected result or has to restart (part of) a procedure. |
|  Warning | Warning             | A “warning” is used when there is danger of personal injury.   |
|          | Reference           | A “reference” guides the reader to other places in this binder or in this manual, where he/she will find additional information on a specific topic.   |

## 1.2 PREFACE

Thank you for your continued patronage of Daikin products.

This is the new service manual for Daikin's Year 2006 VRV series Heat Pump System. Daikin offers a wide range of models to respond to building and office air conditioning needs. We are confident that customers will be able to find the models that best suit their needs.

This service manual contains information regarding the servicing of VRV series Heat Pump System.

Oct., 2006

After Sales Service Division

# Part 1

# General Information

|  |   |
|--|---|
| 1. Model Names of Indoor/Outdoor Units.....  | 2 |
| 2. <a href="#">External Appearance</a> ..... | 3 |
| 2.1 Indoor Units .....                       | 3 |
| 2.2 Outdoor Units .....                      | 3 |
| 3. Model Selection.....                      | 4 |

# 1. Model Names of Indoor/Outdoor Units

## Indoor Units

| Type                                       |      | Model Name |     |     |     |     |     |     |     | Power Supply |
|--|------|------------|-----|-----|-----|-----|-----|-----|-----|--------------|
| Ceiling Mounted Cassette Type (Multi Flow) | FXFQ | —          | —   | 12M | 18M | 24M | 30M | 36M | —   | VJU          |
| Slim Ceiling Mounted Duct Type             | FXDQ | 07M        | 09M | 12M | 18M | 24M | —   | —   | —   |              |
| Ceiling Mounted Built-In Type              | FXSQ | —          | —   | 12M | 18M | 24M | 30M | 36M | 48M |              |
| Ceiling Mounted Duct Type                  | FXMQ | —          | —   | —   | —   | —   | 30M | 36M | 48M |              |
| Ceiling Suspended Type                     | FXHQ | —          | —   | 12M | —   | 24M | —   | 36M | —   |              |
| Wall Mounted Type                          | FXAQ | 07M        | 09M | 12M | 18M | 24M | —   | —   | —   |              |
| Floor Standing Type                        | FXLQ | —          | —   | 12M | 18M | 24M | —   | —   | —   |              |
| Concealed Floor Standing Type              | FXNQ | —          | —   | 12M | 18M | 24M | —   | —   | —   |              |

## Outdoor Units (Inverter Series)

| Series   |           | Model Name |     |     |      |      |      | Power Supply |
|----------|-----------|------------|-----|-----|------|------|------|--------------|
| Inverter | Heat Pump | RXYQ       | 72M | 96M | 144M | 168M | 192M | TJU          |





VJU: 1 $\phi$ , 208~230V, 60Hz

TJU: 3 $\phi$ , 208~230V, 60Hz

This time we publish SiUS39-601 (New information: RXYQ 72, 144, 168MTJU) Wall Mounted Type FXAQ07, 09MVJU) as shown by .

## 2. External Appearance

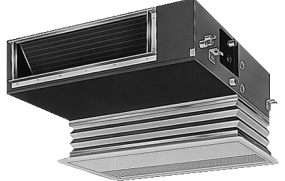
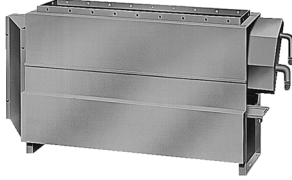
### 2.1 Indoor Units

|  |  |
|--|--|
| <p>Ceiling mounted cassette type (Multi flow)</p> <p>FXFQ12MVJU<br/>FXFQ18MVJU<br/>FXFQ24MVJU<br/>FXFQ30MVJU<br/>FXFQ36MVJU</p>     | <p>Wall mounted type</p> <p><b>FXAQ07MVJU</b><br/><b>FXAQ09MVJU</b><br/>FXAQ12MVJU<br/>FXAQ18MVJU<br/>FXAQ24MVJU</p>  |
| <p>Slim ceiling mounted duct type</p> <p>FXDQ07MVJU<br/>FXDQ09MVJU<br/>FXDQ12MVJU<br/>FXDQ18MVJU<br/>FXDQ24MVJU</p>                 | <p>Floor standing type</p> <p>FXLQ12MVJU<br/>FXLQ18MVJU<br/>FXLQ24MVJU</p>    |
| <p>Ceiling mounted built-in type</p> <p>FXSQ12MVJU<br/>FXSQ18MVJU<br/>FXSQ24MVJU<br/>FXSQ30MVJU<br/>FXSQ36MVJU<br/>FXSQ48MVJU</p>  | <p>Concealed floor standing type</p> <p>FXNQ12MVJU<br/>FXNQ18MVJU<br/>FXNQ24MVJU</p>                                  |
| <p>Ceiling mounted duct type</p> <p>FXMQ30MVJU<br/>FXMQ36MVJU<br/>FXMQ48MVJU</p>    | <p>BS Units</p> <p>BSVQ36MVJU<br/>BSVQ60MVJU</p>    |
| <p>Ceiling suspended type</p> <p>FXHQ12MVJU<br/>FXHQ24MVJU<br/>FXHQ36MVJU</p>   |  |

### 2.2 Outdoor Units

RXYQ72MTJU

RXYQ96MTJU

RXYQ144MTJU

RXYQ168MTJU

RXYQ192MTJU



# 3. Model Selection

## VRV Heat Pump Series

### Connectable Indoor Units Number and Capacity

| Ton  | 6 ton     | 8 ton      | 12 ton   | 14 ton   | 16 ton      |
|--|-----------|------------|----------|----------|-------------|
| System name  | RXYQ72M   | RXYQ96M    | RXYQ144M | RXYQ168M | RXYQ192M    |
| Outdoor unit 1                                       | RXYQ72M   | RXYQ96M    | RXYQ72M  | RXYQ72M  | RXYQ96M     |
| Outdoor unit 2                                       | —         | —          | RXYQ72M  | RXYQ96M  | RXYQ96M     |
| Total number of connectable indoor units             | 12        | 16         | 20       | 20       | 20          |
| Total Capacity Index of Indoor Units to be Connected | 50.5~93.5 | 67.5~124.5 | 101~187  | 118~218  | 134.5~249.5 |

### Connectable Indoor Unit

| Type                                       |      | Model Name |        |      |        |      |        |      |      | Power Supply |
|--|------|------------|--------|------|--------|------|--------|------|------|--------------|
| Capacity Range                             |      | 0.6ton     | 0.8ton | 1ton | 1.5ton | 2ton | 2.5ton | 3ton | 4ton | VJU          |
| Capacity Index                             |      | 7.5        | 9.5    | 12   | 18     | 24   | 30     | 36   | 48   |              |
| Ceiling Mounted Cassette Type (Multi Flow) | FXFQ | —          | —      | 12M  | 18M    | 24M  | 30M    | 36M  | —    |              |
| Slim Ceiling Mounted Duct Type             | FXDQ | 07M        | 09M    | 12M  | 18M    | 24M  | —      | —    | —    |              |
| Ceiling Mounted Built-In Type              | FXSQ | —          | —      | 12M  | 18M    | 24M  | 30M    | 36M  | 48M  |              |
| Ceiling Mounted Duct Type                  | FXMQ | —          | —      | —    | —      | —    | 30M    | 36M  | 48M  |              |
| Ceiling Suspended Type                     | FXHQ | —          | —      | 12M  | —      | 24M  | —      | 36M  | —    |              |
| Wall Mounted Type                          | FXAQ | 07M        | 09M    | 12M  | 18M    | 24M  | —      | —    | —    |              |
| Floor Standing Type                        | FXLQ | —          | —      | 12M  | 18M    | 24M  | —      | —    | —    |              |
| Concealed Floor Standing Type              | FXNQ | —          | —      | 12M  | 18M    | 24M  | —      | —    | —    |              |

### Indoor Unit Capacity

| New refrigerant model code | 07 type     | 09 type     | 12 type      | 18 type      | 24 type      | 30 type      | 36 type      | 48 type      |
|----------------------------|-------------|-------------|--------------|--------------|--------------|--------------|--------------|--------------|
| Selecting model capacity   | 7,500 Btu/h | 9,500 Btu/h | 12,000 Btu/h | 18,000 Btu/h | 24,000 Btu/h | 30,000 Btu/h | 36,000 Btu/h | 48,000 Btu/h |
| Equivalent output          | 0.6 ton     | 0.8 ton     | 1 ton        | 1.5 ton      | 2 ton        | 2.5 ton      | 3 ton        | 4 ton        |

Use the above tables to determine the capacities of indoor units to be connected. Make sure the total capacity of indoor units connected to each outdoor unit is within the specified value (Btu/h).

- The total capacity of connected indoor units must be within a range of 70 to 130% of the rated capacity of the outdoor unit.
- In some models, it is not possible to connect the maximum number of connectable indoor units. Select models so the total capacity of connected indoor units conforms to the specification.

# Part 2

# Specifications

|                         |    |
|-------------------------|----|
| 1. Specifications ..... | 6  |
| 1.1 Outdoor Units ..... | 6  |
| 1.2 Indoor Units .....  | 11 |



# 1. Specifications

## 1.1 Outdoor Units

| Model Name                       |                                | RXYQ72MTJU  |                                    |
|----------------------------------|--------------------------------|---|------------------------------------|
| ★1 Cooling Capacity              | Btu / h                        | 72,000  |                                    |
| ★2 Heating Capacity              | Btu / h                        | 81,000  |                                    |
| Casing Color                     |                                | Ivory White (5Y7.5/1)   |                                    |
| Dimensions: (HxWxD)              |                                | in 64 × 48-7/8 × 30-1/8   |                                    |
| Heat Exchanger                   |                                | Cross Fin Coil  |                                    |
| Comp.                            | Type                           | Hermetically Sealed Scroll Type   |                                    |
|                                  | Piston Displacement            | m <sup>3</sup> /h   | 13.72+10.47                        |
|                                  | Number of Revolutions          | r.p.m   | 6480, 2900                         |
|                                  | Motor Output × Number of Units | kW  | (2.7+4.5) × 1                      |
|                                  | Starting Method                | Direct on line  |                                    |
| Fan                              | Type                           | Propeller Fan   |                                    |
|                                  | Motor Output                   | kW  | 0.75 × 1                           |
|                                  | Air Flow Rate                  | cfm   | 7,400                              |
|                                  | Drive                          | Direct Drive  |                                    |
| Connecting Pipes                 | Liquid Pipe                    | in  | 3/8 in C1220T (Flare Connection)   |
|                                  | Gas Pipe                       | in  | 3/4 in C1220T (Brazing Connection) |
|                                  | Discharge Gas Pipe             | in  | —                                  |
| Machine Weight (Mass)            | Lbs                            | 666   |                                    |
| ★3 Sound Level (Reference Value) | dBA                            | 60  |                                    |
| Safety Devices                   |                                | High Pressure Switch, Fan Driver Overload Protector, Over Current Relay, Inverter Overload Protector, Fusible Plugs, Ground fault circuit interrupter |                                    |
| Defrost Method                   |                                | Deicer  |                                    |
| Capacity Control                 |                                | %   | 14~100                             |
| Refrigerant                      | Refrigerant Name               |   | R-410A                             |
|                                  | Charge                         | Lbs   | 25.1                               |
|                                  | Control                        |   | Electronic Expansion Valve         |
| Refrigerator Oil                 |                                |   | Synthetic (ether) oil              |
|                                  | Charge Volume                  | L   | 1.9+1.6                            |
| Standard Accessories             |                                | Installation Manual, Operation Manual, Connection Pipes, Clamps   |                                    |
| Drawing No.                      |                                | 4D053300A   |                                    |

**Notes:**

- ★1 Indoor temp. : 80°FDB or 67°FWB / outdoor temp. : 95°FDB / Equivalent piping length : 25 ft, level difference: 0.
- ★2 Indoor temp. : 70°FDB / outdoor temp. : 47°FDB or 43°FWB / Equivalent piping length : 25 ft, level difference: 0.
- ★3 Anechoic chamber conversion value, measured under JISB8616 conditions. During actual operation, these values are normally somewhat higher as a result of ambient conditions.

| Model Name                       |                                |                   | RXYQ96MTJU  |
|----------------------------------|--------------------------------|-------------------|---|
| ★1 Cooling Capacity              | Btu / h                        |                   | 96,000  |
| ★2 Heating Capacity              | Btu / h                        |                   | 108,000   |
| Casing Color                     |                                |                   | Ivory White (5Y7.5/1)   |
| Dimensions: (HxWxD)              |                                | in                | 64 × 48-7/8 × 30-1/8  |
| Heat Exchanger                   |                                |                   | Cross Fin Coil  |
| Comp.                            | Type                           |                   | Hermetically Sealed Scroll Type   |
|                                  | Piston Displacement            | m <sup>3</sup> /h | 13.72+10.47   |
|                                  | Number of Revolutions          | r.p.m             | 6480, 2900  |
|                                  | Motor Output × Number of Units | kW                | (2.7+4.5) × 1   |
|                                  | Starting Method                |                   | Direct on line  |
| Fan                              | Type                           |                   | Propeller Fan   |
|                                  | Motor Output                   | kW                | 0.75 × 1  |
|                                  | Air Flow Rate                  | cfm               | 7,400   |
|                                  | Drive                          |                   | Direct Drive  |
| Connecting Pipes                 | Liquid Pipe                    | in                | 3/8 in C1220T (Flare Connection)  |
|                                  | Gas Pipe                       | in                | 7/8 in C1220T (Brazing Connection)  |
|                                  | Discharge Gas Pipe             | in                | —   |
| Machine Weight (Mass)            |                                | Lbs               | 666   |
| ★3 Sound Level (Reference Value) |                                | dBA               | 60  |
| Safety Devices                   |                                |                   | High Pressure Switch, Fan Driver Overload Protector, Over Current Relay, Inverter Overload Protector, Fusible Plugs |
| Defrost Method                   |                                |                   | Deicer  |
| Capacity Control                 |                                | %                 | 14~100  |
| Refrigerant                      | Refrigerant Name               |                   | R-410A  |
|                                  | Charge                         | Lbs               | 25.1  |
|                                  | Control                        |                   | Electronic Expansion Valve  |
| Refrigerator Oil                 |                                |                   | Synthetic (ether) oil   |
|                                  | Charge Volume                  | L                 | 1.9+1.6   |
| Standard Accessories             |                                |                   | Installation Manual, Operation Manual, Connection Pipes, Clamps   |
| Drawing No.                      |                                |                   | 4D042657B   |

- Notes:**
- ★1 Indoor temp. : 80°FDB or 67°FWB / outdoor temp. : 95°FDB / Equivalent piping length : 25 ft, level difference: 0.
  - ★2 Indoor temp. : 70°FDB / outdoor temp. : 47°FDB or 43°FWB / Equivalent piping length : 25 ft, level difference: 0.
  - ★3 Anechoic chamber conversion value, measured under JISB8616 conditions. During actual operation, these values are normally somewhat higher as a result of ambient conditions.

|                                      |                                |   |  |
|--------------------------------------|--------------------------------|---|--|
| <b>Model Name (Combination Unit)</b> |                                | <b>RXYQ144MTJU</b>  |  |
| <b>Model Name (Independent Unit)</b> |                                | <b>RXYQ72MTJU+RXYQ72MTJU</b>  |  |
| ★1 Cooling Capacity                  | Btu / h                        | 144,000   |  |
| ★2 Heating Capacity                  | Btu / h                        | 162,000   |  |
| Casing Color                         |                                | Ivory White (5Y7.5/1)   |  |
| Dimensions: (HxWxD)                  |                                | in (64 × 48-7/8 × 30-1/8) + (64 × 48-7/8 × 30-1/8)  |  |
| Heat Exchanger                       |                                | Cross Fin Coil  |  |
| Comp.                                | Type                           | Hermetically Sealed Scroll Type   |  |
|                                      | Piston Displacement            | m <sup>3</sup> /h   | (13.72+10.47) × 2                                  |
|                                      | Number of Revolutions          | r.p.m   | (6480, 2900) × 2                                   |
|                                      | Motor Output × Number of Units | kW  | (2.7+4.5) × 2                                      |
|                                      | Starting Method                | Direct on line  |  |
| Fan                                  | Type                           | Propeller Fan   |  |
|                                      | Motor Output                   | kW  | 0.75 × 2   |
|                                      | Air Flow Rate                  | cfm   | 7,400+7,400  |
|                                      | Drive                          | Direct Drive  |  |
| Connecting Pipes                     | Liquid Pipe ★3                 | in  | 5/8 in C1220T (Brazing Connection) — Main line —   |
|                                      | Gas Pipe ★3                    | in  | 1-1/8 in C1220T (Brazing Connection) — Main line — |
|                                      | Oil Equalizing Pipe            | in  | φ 1/4 in C1220T (Flare Connection)                 |
| Machine Weight (Mass)                | Lbs                            | 666+666   |  |
| Safety Devices                       |                                | High Pressure Switch, Fan Driver Overload Protector, Over Current Relay, Inverter Overload Protector, Fusible Plugs, Ground fault circuit interrupter |  |
| Defrost Method                       |                                | Deicer  |  |
| Capacity Control                     | %                              | 10~100  |  |
| Refrigerant                          | Refrigerant Name               | R-410A  |  |
|                                      | Charge                         | Lbs   | 25.1+25.1  |
|                                      | Control                        | Electronic Expansion Valve  |  |
| Refrigerator Oil                     |                                |   | Synthetic (ether) oil                              |
|                                      | Charge Volume                  | L   | (1.9+1.6) + (1.9+1.6)                              |
| Standard Accessories                 |                                | Installation Manual, Operation Manual, Connection Pipes, Clamps   |  |
| Drawing No.                          |                                | 4D053301  |  |

**Notes:**

- ★1 Indoor temp. : 80°FDB or 67°FWB / outdoor temp. : 95°FDB / Equivalent piping length : 25 ft, level difference: 0.
- ★2 Indoor temp. : 70°FDB / outdoor temp. : 47°FDB or 43°FWB / Equivalent piping length : 25 ft, level difference: 0.
- ★3 BHFP22M90V is necessary for the connection.  
Concerning about the piping connection for each outdoor unit to the main line as shown above, use REFNET.

|                                      |                                |   |  |
|--------------------------------------|--------------------------------|---|--|
| <b>Model Name (Combination Unit)</b> |                                | <b>RXYQ168MTJU</b>  |  |
| <b>Model Name (Independent Unit)</b> |                                | <b>RXYQ72MTJU+RXYQ96MTJU</b>  |  |
| ★1 Cooling Capacity                  | Btu / h                        | 168,000   |  |
| ★2 Heating Capacity                  | Btu / h                        | 189,000   |  |
| Casing Color                         |                                | Ivory White (5Y7.5/1)   |  |
| Dimensions: (HxWxD)                  |                                | in (64 × 48-7/8 × 30-1/8) + (64 × 48-7/8 × 30-1/8)  |  |
| Heat Exchanger                       |                                | Cross Fin Coil  |  |
| Comp.                                | Type                           | Hermetically Sealed Scroll Type   |  |
|                                      | Piston Displacement            | m <sup>3</sup> /h   | (13.72+10.47) × 2                                  |
|                                      | Number of Revolutions          | r.p.m   | (6480, 2900) × 2                                   |
|                                      | Motor Output × Number of Units | kW  | (2.7+4.5) × 2                                      |
|                                      | Starting Method                | Direct on line  |  |
| Fan                                  | Type                           | Propeller Fan   |  |
|                                      | Motor Output                   | kW  | 0.75 × 2   |
|                                      | Air Flow Rate                  | cfm   | 7,400+7,400  |
|                                      | Drive                          | Direct Drive  |  |
| Connecting Pipes                     | Liquid Pipe ★3                 | in  | 5/8 in C1220T (Brazing Connection) — Main line —   |
|                                      | Gas Pipe ★3                    | in  | 1-1/8 in C1220T (Brazing Connection) — Main line — |
|                                      | Oil Equalizing Pipe            | in  | φ 1/4 in C1220T (Flare Connection)                 |
| Machine Weight (Mass)                | Lbs                            | 666+666   |  |
| Safety Devices                       |                                | High Pressure Switch, Fan Driver Overload Protector, Over Current Relay, Inverter Overload Protector, Fusible Plugs, Ground fault circuit interrupter |  |
| Defrost Method                       |                                | Deicer  |  |
| Capacity Control                     | %                              | 7~100   |  |
| Refrigerant                          | Refrigerant Name               | R-410A  |  |
|                                      | Charge                         | Lbs   | 25.1+25.1  |
|                                      | Control                        | Electronic Expansion Valve  |  |
| Refrigerator Oil                     |                                |   | Synthetic (ether) oil                              |
|                                      | Charge Volume                  | L   | (1.9+1.6) + (1.9+1.6)                              |
| Standard Accessories                 |                                | Installation Manual, Operation Manual, Connection Pipes, Clamps   |  |
| Drawing No.                          |                                | 4D053302  |  |

**Notes:**

- ★1 Indoor temp. : 80°FDB or 67°FWB / outdoor temp. : 95°FDB / Equivalent piping length : 25 ft, level difference: 0.
- ★2 Indoor temp. : 70°FDB / outdoor temp. : 47°FDB or 43°FWB / Equivalent piping length : 25 ft, level difference: 0.
- ★3 BHFP22M90V is necessary for the connection.  
Concerning about the piping connection for each outdoor unit to the main line as shown above, use REFNET.

|                                      |                                |   |  |
|--------------------------------------|--------------------------------|---|--|
| <b>Model Name (Combination Unit)</b> |                                | <b>RXYQ192MTJU</b>  |  |
| <b>Model Name (Independent Unit)</b> |                                | <b>RXYQ96MTJU+RXYQ96MTJU</b>  |  |
| ★1 Cooling Capacity                  | Btu / h                        | 192,000   |  |
| ★2 Heating Capacity                  | Btu / h                        | 216,000   |  |
| Casing Color                         |                                | Ivory White (5Y7.5/1)   |  |
| Dimensions: (HxWxD)                  |                                | in (64 × 48-7/8 × 30-1/8) + (64 × 48-7/8 × 30-1/8)  |  |
| Heat Exchanger                       |                                | Cross Fin Coil  |  |
| Comp.                                | Type                           | Hermetically Sealed Scroll Type   |  |
|                                      | Piston Displacement            | m <sup>3</sup> /h   | (13.72+10.47) × 2                                  |
|                                      | Number of Revolutions          | r.p.m   | (6480, 2900) × 2                                   |
|                                      | Motor Output × Number of Units | kW  | (2.7+4.5) × 2                                      |
|                                      | Starting Method                | Direct on line  |  |
| Fan                                  | Type                           | Propeller Fan   |  |
|                                      | Motor Output                   | kW  | 0.75 × 2   |
|                                      | Air Flow Rate                  | cfm   | 7,400+7,400  |
|                                      | Drive                          | Direct Drive  |  |
| Connecting Pipes                     | Liquid Pipe ★3                 | in  | 5/8 in C1220T (Brazing Connection) — Main line —   |
|                                      | Gas Pipe ★3                    | in  | 1-1/8 in C1220T (Brazing Connection) — Main line — |
|                                      | Oil Equalizing Pipe            | in  | φ 1/4 in C1220T (Flare Connection)                 |
| Machine Weight (Mass)                |                                | Lbs   | 666+666  |
| Safety Devices                       |                                | High Pressure Switch, Fan Driver Overload Protector, Over Current Relay, Inverter Overload Protector, Fusible Plugs |  |
| Defrost Method                       |                                | Deicer  |  |
| Capacity Control                     |                                | %   | 7~100  |
| Refrigerant                          | Refrigerant Name               |   | R-410A   |
|                                      | Charge                         | Lbs   | 25.1+25.1  |
|                                      | Control                        |   | Electronic Expansion Valve                         |
| Refrigerator Oil                     |                                |   | Synthetic (ether) oil                              |
|                                      | Charge Volume                  | L   | (1.9+1.6) + (1.9+1.6)                              |
| Standard Accessories                 |                                | Installation Manual, Operation Manual, Connection Pipes, Clamps   |  |
| Drawing No.                          |                                | 4D050355  |  |

- Notes:**
- ★1 Indoor temp. : 80°FDB or 67°FWB / outdoor temp. : 95°FDB / Equivalent piping length : 25 ft, level difference: 0.
  - ★2 Indoor temp. : 70°FDB / outdoor temp. : 47°FDB or 43°FWB / Equivalent piping length : 25 ft, level difference: 0.
  - ★3 BHFP22M90V is necessary for the connection.  
Concerning about the piping connection for each outdoor unit to the main line as shown above, use REFNET.

# 1.2 Indoor Units

## Ceiling Mounted Cassette Type (Multi-flow)

| Model                                       |                     |                 | FXFQ12MVJU   | FXFQ18MVJU   | FXFQ24MVJU   |
|---|---------------------|-----------------|--|--|--|
| ★1 Cooling Capacity                         | Btu/h               |                 | 12,000   | 18,000   | 24,000   |
| ★2 Heating Capacity                         | Btu/h               |                 | 13,500   | 20,000   | 27,000   |
| Casing / Color                              |                     |                 | Galvanized Steel Plate   | Galvanized Steel Plate   | Galvanized Steel Plate   |
| Dimensions: (H×W×D)                         |                     | in              | 9-1/8×33-1/8×33-1/8  | 9-1/8×33-1/8×33-1/8  | 9-1/8×33-1/8×33-1/8  |
| Coil (Cross Fin Coil)                       | Rows × Stages × FPI |                 | 2×8×17   | 2×8×17   | 2×8×17   |
|   | Face Area           | ft <sup>2</sup> | 3.56   | 3.56   | 3.56   |
| Fan   | Model               |                 | QTS45B14M  | QTS45B14M  | QTS45B14M  |
|   | Type                |                 | Turbo Fan  | Turbo Fan  | Turbo Fan  |
|   | Motor Output        | HP              | 0.06   | 0.06   | 0.06   |
|   | Air Flow Rate (H/L) | cfm             | 460/350  | 570/390  | 670/490  |
| Drive                                       |                     |                 | Direct Drive   | Direct Drive   | Direct Drive   |
| Temperature Control                         |                     |                 | Microprocessor Thermostat for Cooling and Heating  | Microprocessor Thermostat for Cooling and Heating  | Microprocessor Thermostat for Cooling and Heating  |
| Sound Absorbing Thermal Insulation Material |                     |                 | Foamed Polystyrene / Foamed Polyethylene   | Foamed Polystyrene / Foamed Polyethylene   | Foamed Polystyrene / Foamed Polyethylene   |
| Piping Connections                          | Liquid Pipes        | in              | φ1/4 (Flare Connection)  | φ1/4 (Flare Connection)  | φ3/8 (Flare Connection)  |
|   | Gas Pipes           | in              | φ1/2 (Flare Connection)  | φ1/2 (Flare Connection)  | φ5/8 (Flare Connection)  |
|   | Drain Pipe          | in              | VP25<br>( External Dia. 1-1/4<br>Internal Dia. 1 )   | VP25<br>( External Dia. 1-1/4<br>Internal Dia. 1 )   | VP25<br>( External Dia. 1-1/4<br>Internal Dia. 1 )   |
| Machine Weight (Mass)                       | Lbs                 |                 | 55   | 55   | 55   |
| ★4 Sound Level (H/L)                        | dBA                 |                 | 31/28  | 33/28  | 34/29  |
| Safety Devices                              |                     |                 | Fuse, Thermal Protector for Fan Motor  | Fuse, Thermal Protector for Fan Motor  | Fuse, Thermal Protector for Fan Motor  |
| Refrigerant Control                         |                     |                 | Electronic Expansion Valve   | Electronic Expansion Valve   | Electronic Expansion Valve   |
| Connectable outdoor unit                    |                     |                 | R-410A Series  | R-410A Series  | R-410A Series  |
| Decoration Panels (Option)                  | Model               |                 | BYC125K-W1   | BYC125K-W1   | BYC125K-W1   |
|   | Color               |                 | White (10Y9/0.5)   | White (10Y9/0.5)   | White (10Y9/0.5)   |
|   | Dimensions: (H×W×D) | in              | 1-5/8×37-3/8×37-3/8  | 1-5/8×37-3/8×37-3/8  | 1-5/8×37-3/8×37-3/8  |
|   | Air Filter          |                 | Resin Net<br>(with Mold Resistant)   | Resin Net<br>(with Mold Resistant)   | Resin Net<br>(with Mold Resistant)   |
| Weight                                      | Lbs                 |                 | 11   | 11   | 11   |
| Standard Accessories                        |                     |                 | Operation manual, Installation manual, Paper pattern for installation, Drain hose, Clamp metal, Washers, Sealing pads, Clamps, Screws, Insulation for fitting. | Operation manual, Installation manual, Paper pattern for installation, Drain hose, Clamp metal, Washers, Sealing pads, Clamps, Screws, Insulation for fitting. | Operation manual, Installation manual, Paper pattern for installation, Drain hose, Clamp metal, Washers, Sealing pads, Clamps, Screws, Insulation for fitting. |
| Drawing No.                                 |                     |                 | C:3D042686   |  |  |

- Notes:**
- ★1 Nominal cooling capacities are based on the following conditions:  
Return air temperature: 80°FDB, 67°FWB  
Outdoor temperature: 95°FDB  
Equivalent ref. piping length: 25ft (Horizontal)
  - ★2 Nominal heating capacities are based on the following conditions:  
Return air temperature: 70°FDB  
Outdoor temperature: 47°FDB, 43°FWB  
Equivalent ref. piping length: 25ft (Horizontal)
  - 3 Capacities are net, including a deduction for cooling (an addition for heating) for indoor fan motor heat.
  - ★4 Anechoic chamber conversion value, measured under JISB8616 conditions. During actual operation, these values are normally somewhat higher as a result of installation conditions.

## Ceiling Mounted Cassette Type (Multi-flow)

| Model                                       |                     | FXFQ30MVJU   |  | FXFQ36MVJU   |  |  |
|---|---------------------|--|--|--|--|--|
| ★1 Cooling Capacity                         | Btu/h               | 30,000   |  | 36,000   |  |  |
| ★2 Heating Capacity                         | Btu/h               | 34,000   |  | 40,000   |  |  |
| Casing / Color                              |                     | Galvanized Steel Plate   |  | Galvanized Steel Plate   |  |  |
| Dimensions: (HxWxD)                         |                     | in 11-3/8 x 33-1/8 x 33-1/8  |  | 11-3/8 x 33-1/8 x 33-1/8   |  |  |
| Coil (Cross Fin Coil)                       | Rows x Stages x FPI | 2 x 12 x 17  |  | 2x12x17  |  |  |
|   | Face Area           | ft <sup>2</sup>  | 5.35   |  | 5.35   |  |
| Fan   | Model               | QTS45A17M  |  | QTS45A17M  |  |  |
|   | Type                | Turbo Fan  |  | Turbo Fan  |  |  |
|   | Motor Output        | HP   | 0.12   |  | 0.12   |  |
|   | Air Flow Rate (H/L) | cfm  | 990/710  |  | 990/740  |  |
|   | Drive               | Direct Drive   |  | Direct Drive   |  |  |
| Temperature Control                         |                     | Microprocessor Thermostat for Cooling and Heating  |  | Microprocessor Thermostat for Cooling and Heating  |  |  |
| Sound Absorbing Thermal Insulation Material |                     | Foamed Polystyrene / Foamed Polyethylene   |  | Foamed Polystyrene / Foamed Polyethylene   |  |  |
| Piping Connections                          | Liquid Pipes        | in   | φ3/8 (Flare Connection)                            |  | φ3/8 (Flare Connection)                            |  |
|   | Gas Pipes           | in   | φ5/8 (Flare Connection)                            |  | φ5/8 (Flare Connection)                            |  |
|   | Drain Pipe          | in   | VP25<br>( External Dia. 1-1/4<br>Internal Dia. 1 ) |  | VP25<br>( External Dia. 1-1/4<br>Internal Dia. 1 ) |  |
| Machine Weight (Mass)                       | Lbs                 | 66   |  | 66   |  |  |
| ★4 Sound Level (H/L)                        | dBA                 | 38/32  |  | 40/33  |  |  |
| Safety Devices                              |                     | Fuse, Thermal Protector for Fan Motor  |  | Fuse, Thermal Protector for Fan Motor  |  |  |
| Refrigerant Control                         |                     | Electronic Expansion Valve   |  | Electronic Expansion Valve   |  |  |
| Connectable outdoor unit                    |                     | R-410A Series  |  | R-410A Series  |  |  |
| Decoration Panels (Option)                  | Model               | BYC125K-W1   |  | BYC125K-W1   |  |  |
|   | Color               | White (10Y9/0.5)   |  | White (10Y9/0.5)   |  |  |
|   | Dimensions: (HxWxD) | in   | 1-5/8 x 37-3/8 x 37-3/8                            |  | 1-5/8 x 37-3/8 x 37-3/8                            |  |
|   | Air Filter          | Resin Net<br>(with Mold Resistant)   |  | Resin Net<br>(with Mold Resistant)   |  |  |
|   | Weight              | Lbs  | 11   |  | 11   |  |
| Standard Accessories                        |                     | Operation manual, Installation manual, Paper pattern for installation, Drain hose, Clamp metal, Washers, Sealing pads, Clamps, Screws, Insulation for fitting. |  | Operation manual, Installation manual, Paper pattern for installation, Drain hose, Clamp metal, Washers, Sealing pads, Clamps, Screws, Insulation for fitting. |  |  |
| Drawing No.                                 |                     | C:3D042686   |  |  |  |  |

**Notes:**

- ★1 Nominal cooling capacities are based on the following conditions:  
Return air temperature: 80°FDB, 67°FWB  
Outdoor temperature: 95°FDB  
Equivalent ref. piping length : 25ft (Horizontal)
- ★2 Nominal heating capacities are based on the following conditions:  
Return air temperature: 70°FDB.  
Outdoor temperature: 47°FDB, 43°FWB  
Equivalent ref. piping length: 25ft (Horizontal)
- 3 Capacities are net, including a deduction for cooling (an addition for heating) for indoor fan motor heat.
- ★4 Anechoic chamber conversion value, measured under JISB8616 conditions. During actual operation, these values are normally somewhat higher as a result of installation conditions.

## Slim Ceiling Mounted Duct Type

| Model                                       |                             |                 | FXDQ07MVJU  | FXDQ09MVJU  | FXDQ12MVJU  |
|---|-----------------------------|-----------------|---|---|---|
| ★1 Cooling Capacity                         | Btu/h                       |                 | 7,500   | 9,500   | 12,000  |
| ★2 Heating Capacity                         | Btu/h                       |                 | 8,500   | 10,500  | 13,500  |
| Casing / Color                              |                             |                 | Galvanized Steel Plate  | Galvanized Steel Plate  | Galvanized Steel Plate  |
| Dimensions: (HxWxD)                         |                             | in              | 7-7/8 x 27-9/16 x 24-7/16   | 7-7/8 x 27-9/16 x 24-7/16   | 7-7/8 x 27-9/16 x 24-7/16   |
| Coil (Cross Fin Coil)                       | Rows x Stages x FPI         |                 | 2 x 12 x 17   | 2 x 12 x 17   | 3 x 12 x 17   |
|   | Face Area                   | ft <sup>2</sup> | 1.36  | 1.36  | 1.36  |
| Fan   | Model                       |                 | —   | —   | —   |
|   | Type                        |                 | Sirocco Fan   | Sirocco Fan   | Sirocco Fan   |
|   | Motor Output                | HP              | 0.08  | 0.08  | 0.08  |
|   | Air Flow Rate (H/L)         | cfm             | 280/226 (H/L)   | 280/226 (H/L)   | 280/226 (H/L)   |
|   | External Static Pressure ★4 | Pa              | 30-10   | 30-10   | 30-10   |
|   | Drive                       |                 | Direct Drive  | Direct Drive  | Direct Drive  |
| Temperature Control                         |                             |                 | Microprocessor Thermostat for Cooling and Heating   | Microprocessor Thermostat for Cooling and Heating   | Microprocessor Thermostat for Cooling and Heating   |
| Sound Absorbing Thermal Insulation Material |                             |                 | Foamed Polyethylene   | Foamed Polyethylene   | Foamed Polyethylene   |
| Air Filter                                  |                             |                 | Removal, Washable, Mildew Proof   | Removal, Washable, Mildew Proof   | Removal, Washable, Mildew Proof   |
| Piping Connections                          | Liquid Pipes                | in              | φ1/4 (Flare Connection)   | φ1/4 (Flare Connection)   | φ1/4 (Flare Connection)   |
|   | Gas Pipes                   | in              | φ1/2 (Flare Connection)   | φ1/2 (Flare Connection)   | φ1/2 (Flare Connection)   |
|   | Drain Pipe                  | in              | VP20<br>(External Dia. 1-1/32 Internal Dia. 25/32)  | VP20<br>(External Dia. 1-1/32 Internal Dia. 25/32)  | VP20<br>(External Dia. 1-1/32 Internal Dia. 25/32)  |
| Machine Weight (Mass)                       | Lbs                         | 51              | 51  | 51  |   |
| ★5 Sound Level (H/L)                        | dBA                         | 33/29           | 33/29   | 33/29   |   |
| Safety Devices                              |                             |                 | Fuse,<br>Thermal Protector for Fan Motor  | Fuse,<br>Thermal Protector for Fan Motor  | Fuse,<br>Thermal Protector for Fan Motor  |
| Refrigerant Control                         |                             |                 | Electronic Expansion Valve  | Electronic Expansion Valve  | Electronic Expansion Valve  |
| Connectable outdoor unit                    |                             |                 | R-410A Series   | R-410A Series   | R-410A Series   |
| Standard Accessories                        |                             |                 | Operation Manual, Installation Manual, Paper Pattern for Installation, Drain Hose, Clamp Metal, Insulation for Fitting, Sealing Pads, Clamps, Screws, Washers, Conduit Mounting Plate, Insulation Tube. | Operation Manual, Installation Manual, Paper Pattern for Installation, Drain Hose, Clamp Metal, Insulation for Fitting, Sealing Pads, Clamps, Screws, Washers, Conduit Mounting Plate, Insulation Tube. | Operation Manual, Installation Manual, Paper Pattern for Installation, Drain Hose, Clamp Metal, Insulation for Fitting, Sealing Pads, Clamps, Screws, Washers, Conduit Mounting Plate, Insulation Tube. |
| Drawing No.                                 |                             |                 | C:3D051780A   |   |   |

**Notes:**

- ★1 Nominal cooling capacities are based on the following conditions:  
Return air temperature: 80°FDB, 67°FWB  
Outdoor temperature: 95°FDB  
Equivalent ref. piping length: 25ft (Horizontal)
- ★2 Nominal heating capacities are based on the following conditions:  
Return air temperature: 70°FDB.  
Outdoor temperature: 47°FDB, 43°FWB  
Equivalent ref. piping length: 25ft (Horizontal)
- 3 Capacities are net, including a deduction for cooling (an addition for heating) for indoor fan motor heat.
- ★4 External static pressure is changeable to change over the connectors inside electrical box, this pressure means "High static pressure – Standard – Low static pressure".
- ★5 Anechoic chamber conversion value, measured under JISB8616 conditions. During actual operation, these values are normally somewhat higher as a result of installation conditions.



**Slim Ceiling Mounted Duct Type**

| Model                                       |                             |                 | FXDQ18MVJU  | FXDQ24MVJU  |
|---|-----------------------------|-----------------|---|---|
| ★1 Cooling Capacity                         |                             | Btu/h           | 18,000  | 24,000  |
| ★2 Heating Capacity                         |                             | Btu/h           | 20,000  | 27,000  |
| Casing / Color                              |                             |                 | Galvanized Steel Plate  | Galvanized Steel Plate  |
| Dimensions: (HxWxD)                         |                             | in              | 7-7/8 x 35-7/16 x 24-7/16   | 7-7/8 x 43-5/16 x 24-7/16   |
| Coil (Cross Fin Coil)                       | Rows x Stages x FPI         |                 | 3 x 12 x 17   | 3 x 12 x 17   |
|   | Face Area                   | ft <sup>2</sup> | 1.89  | 2.44  |
| Fan   | Model                       |                 | —   | —   |
|   | Type                        |                 | Sirocco Fan   | Sirocco Fan   |
|   | Motor Output                | HP              | 0.17  | 0.17  |
|   | Air Flow Rate (H/L)         | cfm             | 440/350 (H/L)   | 580/460 (H/L)   |
|   | External Static Pressure ★4 | Pa              | 44-15   | 44-15   |
| Drive                                       |                             |                 | Direct Drive  | Direct Drive  |
| Temperature Control                         |                             |                 | Microprocessor Thermostat for Cooling and Heating   | Microprocessor Thermostat for Cooling and Heating   |
| Sound Absorbing Thermal Insulation Material |                             |                 | Foamed Polyethylene   | Foamed Polyethylene   |
| Air Filter                                  |                             |                 | Removal, Washable, Mildew Proof   | Removal, Washable, Mildew Proof   |
| Piping Connections                          | Liquid Pipes                | in              | φ1/4 (Flare Connection)   | φ3/8 (Flare Connection)   |
|   | Gas Pipes                   | in              | φ1/2 (Flare Connection)   | φ5/8 (Flare Connection)   |
|   | Drain Pipe                  | in              | VP20<br>(External Dia. 1-1/32 Internal Dia. 25/32)  | VP20<br>(External Dia. 1-1/32 Internal Dia. 25/32)  |
| Machine Weight (Mass)                       | Lbs                         | 63              | 71  |   |
| ★5 Sound Level (H/L)                        | dBA                         | 35/31           | 36/32   |   |
| Safety Devices                              |                             |                 | Fuse, Thermal Protector for Fan Motor   | Fuse, Thermal Protector for Fan Motor   |
| Refrigerant Control                         |                             |                 | Electronic Expansion Valve  | Electronic Expansion Valve  |
| Connectable outdoor unit                    |                             |                 | R-410A Series   | R-410A Series   |
| Standard Accessories                        |                             |                 | Operation Manual, Installation Manual, Paper Pattern for Installation, Drain Hose, Clamp Metal, Insulation for Fitting, Sealing Pads, Clamps, Screws, Washers, Conduit Mounting Plate, Insulation Tube. | Operation Manual, Installation Manual, Paper Pattern for Installation, Drain Hose, Clamp Metal, Insulation for Fitting, Sealing Pads, Clamps, Screws, Washers, Conduit Mounting Plate, Insulation Tube. |
| Drawing No.                                 |                             |                 | C:3D051780A   |   |

- Notes:**
- ★1 Nominal cooling capacities are based on the following conditions:  
Return air temperature: 80°FDB, 67°FWB  
Outdoor temperature: 95°FDB  
Equivalent ref. piping length: 25ft (Horizontal)
  - ★2 Nominal heating capacities are based on the following conditions:  
Return air temperature: 70°FDB.  
Outdoor temperature: 47°FDB, 43°FWB  
Equivalent ref. piping length: 25ft (Horizontal)
  - 3 Capacities are net, including a deduction for cooling (an addition for heating) for indoor fan motor heat.
  - ★4 External static pressure is changeable to change over the connectors inside electrical box, this pressure means "High static pressure – Standard – Low static pressure".
  - ★5 Anechoic chamber conversion value, measured under JISB8616 conditions. During actual operation, these values are normally somewhat higher as a result of installation conditions.

## Ceiling Mounted Built-in Type

| Model                                       |                             |                 | FXSQ12MVJU   | FXSQ18MVJU   | FXSQ24MVJU   |
|---|-----------------------------|-----------------|--|--|--|
| ★1 Cooling Capacity                         | Btu/h                       |                 | 12,000   | 18,000   | 24,000   |
| ★2 Heating Capacity                         | Btu/h                       |                 | 13,500   | 20,000   | 27,000   |
| Casing / Color                              |                             |                 | Galvanized Steel Plate   | Galvanized Steel Plate   | Galvanized Steel Plate   |
| Dimensions: (HxWxD)                         |                             | in              | 11-7/8 x 21-5/8 x 31-1/2   | 11-7/8 x 27-1/2 x 31-1/2   | 11-7/8 x 39-3/8 x 31-1/2   |
| Coil (Cross Fin Coil)                       | Rows x Stages x FPI         |                 | 3 x 14 x 14  | 3 x 14 x 14  | 3 x 14 x 14  |
|   | Face Area                   | ft <sup>2</sup> | 0.95   | 1.42   | 2.38   |
| Fan   | Model                       |                 | D18H3A   | D18H2A   | 2D18H2A  |
|   | Type                        |                 | Sirocco Fan  | Sirocco Fan  | Sirocco Fan  |
|   | Motor Output                | HP              | 0.07   | 0.11   | 0.17   |
|   | Air Flow Rate (H/L)         | cfm             | 340/230  | 530/390  | 740/490  |
|   | External Static Pressure ★4 | in. Aq          | 0.37-0.19-0.06   | 0.38-0.19-0.06   | 0.51-0.29-0.06   |
| Drive                                       |                             | Direct Drive    | Direct Drive   | Direct Drive   |  |
| Temperature Control                         |                             |                 | Microprocessor Thermostat for Cooling and Heating  | Microprocessor Thermostat for Cooling and Heating  | Microprocessor Thermostat for Cooling and Heating  |
| Sound Absorbing Thermal Insulation Material |                             |                 | Glass Fiber  | Glass Fiber  | Glass Fiber  |
| Air Filter                                  |                             |                 | Resin Net (with Mold Resistant)  | Resin Net (with Mold Resistant)  | Resin Net (with Mold Resistant)  |
| Piping Connections                          | Liquid Pipes                | in              | φ1/4 (Flare Connection)  | φ1/4 (Flare Connection)  | φ3/8 (Flare Connection)  |
|   | Gas Pipes                   | in              | φ1/2 (Flare Connection)  | φ1/2 (Flare Connection)  | φ5/8 (Flare Connection)  |
|   | Drain Pipe                  | in              | VP25<br>(External Dia. 1-1/4 Internal Dia. 1)  | VP25<br>(External Dia. 1-1/4 Internal Dia. 1)  | VP25<br>(External Dia. 1-1/4 Internal Dia. 1)  |
| Machine Weight (Mass)                       | Lbs                         |                 | 69   | 73   | 95   |
| ★5 Sound Level (H/L)                        | dBA                         |                 | 41/35  | 44/38  | 44/38  |
| Safety Devices                              |                             |                 | Fuse,<br>Thermal Protector for Fan Motor   | Fuse,<br>Thermal Protector for Fan Motor   | Fuse,<br>Thermal Protector for Fan Motor   |
| Refrigerant Control                         |                             |                 | Electronic Expansion Valve   | Electronic Expansion Valve   | Electronic Expansion Valve   |
| Connectable outdoor unit                    |                             |                 | R-410A Series  | R-410A Series  | R-410A Series  |
| Decoration Panel (Option)                   | Model                       |                 | BYBS32DJW1   | BYBS45DJW1   | BYBS71DJW1   |
|   | Panel Color                 |                 | White (10Y9/0.5)   | White (10Y9/0.5)   | White (10Y9/0.5)   |
|   | Dimensions: (HxWxD)         | in              | 2-1/8 x 25-5/8 x 19-5/8  | 2-1/8 x 31-1/2 x 19-5/8  | 2-1/8 x 43-1/4 x 19-5/8  |
| Weight                                      | Lbs                         |                 | 6.6  | 7.7  | 9.9  |
| Standard Accessories                        |                             |                 | Operation Manual, Installation Manual, Paper Pattern for Installation, Drain Hose, Clamp Metal, Insulation for Fitting, Sealing Pads, Clamps, Screws, Washers. | Operation Manual, Installation Manual, Paper Pattern for Installation, Drain Hose, Clamp Metal, Insulation for Fitting, Sealing Pads, Clamps, Screws, Washers. | Operation Manual, Installation Manual, Paper Pattern for Installation, Drain Hose, Clamp Metal, Insulation for Fitting, Sealing Pads, Clamps, Screws, Washers. |
| Drawing No.                                 |                             |                 | C:3D042684   |  |  |

**Notes:**

- ★1 Nominal cooling capacities are based on the following conditions:  
Return air temperature: 80°FDB, 67°FWB  
Outdoor temperature: 95°FDB  
Equivalent ref. piping length: 25ft (Horizontal)
- ★2 Nominal heating capacities are based on the following conditions:  
Return air temperature: 70°FDB.  
Outdoor temperature: 47°FDB, 43°FWB  
Equivalent ref. piping length: 25ft (Horizontal)
- 3 Capacities are net, including a deduction for cooling (an addition for heating) for indoor fan motor heat.
- ★4 External static pressure is changeable to change over the connectors inside electrical box, this pressure means "High static pressure – Standard – Low static pressure".
- ★5 Anechoic chamber conversion value, measured under JISB8616 conditions. During actual operation, these values are normally somewhat higher as a result of installation conditions.

**Ceiling Mounted Built-in Type**

| Model                                       |                             |                 | FXSQ30MVJU   | FXSQ36MVJU   | FXSQ48MVJU   |
|---|-----------------------------|-----------------|--|--|--|
| ★1 Cooling Capacity                         | Btu/h                       |                 | 30,000   | 36,000   | 48,000   |
| ★2 Heating Capacity                         | Btu/h                       |                 | 34,000   | 40,000   | 54,000   |
| Casing / Color                              |                             |                 | Galvanized Steel Plate   | Galvanized Steel Plate   | Galvanized Steel Plate   |
| Dimensions: (HxWxD)                         |                             | in              | 11-7/8×55-1/8×31-1/2   | 11-7/8×55-1/8×31-1/2   | 11-7/8×55-1/8×31-1/2   |
| Coil (Cross Fin Coil)                       | Rows × Stages × FPI         |                 | 3 × 14 × 14  | 3 × 14 × 14  | 3 × 14 × 14  |
|   | Face Area                   | ft <sup>2</sup> | 3.64   | 3.64   | 3.64   |
| Fan   | Model                       |                 | 3D18H2A  | 3D18H2A  | 3D18H2A  |
|   | Type                        |                 | Sirocco Fan  | Sirocco Fan  | Sirocco Fan  |
|   | Motor Output                | HP              | 0.30   | 0.30   | 0.30   |
|   | Air Flow Rate (H/L)         | cfm             | 950/720  | 990/740  | 1,300/950  |
|   | External Static Pressure ★4 | in. Aq          | 0.57-0.39  | 0.57-0.35  | 0.34-0.10  |
|   | Drive                       |                 | Direct Drive   | Direct Drive   | Direct Drive   |
| Temperature Control                         |                             |                 | Microprocessor Thermostat for Cooling and Heating  | Microprocessor Thermostat for Cooling and Heating  | Microprocessor Thermostat for Cooling and Heating  |
| Sound Absorbing Thermal Insulation Material |                             |                 | Glass Fiber  | Glass Fiber  | Glass Fiber  |
| Air Filter                                  |                             |                 | Resin Net (with Mold Resistant)  | Resin Net (with Mold Resistant)  | Resin Net (with Mold Resistant)  |
| Piping Connections                          | Liquid Pipes                | in              | φ3/8 (Flare Connection)  | φ3/8 (Flare Connection)  | φ3/8 (Flare Connection)  |
|   | Gas Pipes                   | in              | φ5/8 (Flare Connection)  | φ5/8 (Flare Connection)  | φ5/8 (Flare Connection)  |
|   | Drain Pipe                  | in              | VP25 (External Dia. 1-1/4 Internal Dia. 1)   | VP25 (External Dia. 1-1/4 Internal Dia. 1)   | VP25 (External Dia. 1-1/4 Internal Dia. 1)   |
| Machine Weight (Mass)                       | Lbs                         |                 | 119  | 119  | 122  |
| ★5 Sound Level (H/L)                        | dBA                         |                 | 45/39  | 45/39  | 48/43  |
| Safety Devices                              |                             |                 | Fuse, Thermal Protector for Fan Motor  | Fuse, Thermal Protector for Fan Motor  | Fuse, Thermal Protector for Fan Motor  |
| Refrigerant Control                         |                             |                 | Electronic Expansion Valve   | Electronic Expansion Valve   | Electronic Expansion Valve   |
| Connectable outdoor unit                    |                             |                 | R-410A Series  | R-410A Series  | R-410A Series  |
| Decoration Panel (Option)                   | Model                       |                 | BYBS125DJW1  | BYBS125DJW1  | BYBS125DJW1  |
|   | Panel Color                 |                 | White (10Y9/0.5)   | White (10Y9/0.5)   | White (10Y9/0.5)   |
|   | Dimensions: (HxWxD)         | in              | 2-1/8 × 59 × 19-5/8  | 2-1/8 × 59 × 19-5/8  | 2-1/8 × 59 × 19-5/8  |
|   | Weight                      | Lbs             | 14   | 14   | 14   |
| Standard Accessories                        |                             |                 | Operation Manual, Installation Manual, Paper Pattern for Installation, Drain Hose, Clamp Metal, Insulation for Fitting, Sealing Pads, Clamps, Screws, Washers. | Operation Manual, Installation Manual, Paper Pattern for Installation, Drain Hose, Clamp Metal, Insulation for Fitting, Sealing Pads, Clamps, Screws, Washers. | Operation Manual, Installation Manual, Paper Pattern for Installation, Drain Hose, Clamp Metal, Insulation for Fitting, Sealing Pads, Clamps, Screws, Washers. |
| Drawing No.                                 |                             |                 | C:3D042684   |  |  |

**Notes:**

- ★1 Nominal cooling capacities are based on the following conditions:  
Return air temperature: 80°FDB, 67°FWB  
Outdoor temperature: 95°FDB  
Equivalent ref. piping length: 25ft (Horizontal)
- ★2 Nominal heating capacities are based on the following conditions:  
Return air temperature: 70°FDB.  
Outdoor temperature: 47°FDB, 43°FWB  
Equivalent ref. piping length: 25ft (Horizontal)
- 3 Capacities are net, including a deduction for cooling (an addition for heating) for indoor fan motor heat.
- ★4 External static pressure is changeable to change over the connectors inside electrical box, this pressure means "High static pressure – Standard".
- ★5 Anechoic chamber conversion value, measured under JISB8616 conditions. During actual operation, these values are normally somewhat higher as a result of installation conditions.

**Ceiling Mounted Duct Type**

| Model                                       |                             | FXMQ30MVJU  | FXMQ36MVJU  | FXMQ48MVJU  |
|---|-----------------------------|---|---|---|
| ★1 Cooling Capacity                         | Btu/h                       | 30,000  | 36,000  | 48,000  |
| ★2 Heating Capacity                         | Btu/h                       | 34,000  | 40,000  | 54,000  |
| Casing / Color                              |                             | Galvanized Steel Plate  | Galvanized Steel Plate  | Galvanized Steel Plate  |
| Dimensions: (HxWxD)                         |                             | in 15-3/8x28-3/8x27-1/8   | 15-3/8x43-3/4x27-1/8  | 15-3/8x43-3/4x27-1/8  |
| Coil (Cross Fin Coil)                       | Rows x Stages x FPI         | 3x16x13   | 3x16x13   | 3x16x13   |
|   | Face Area                   | ft <sup>2</sup> 1.95  | 3.43  | 3.43  |
| Fan   | Model                       | D11/2D3AA1VE  | 2D11/2D3AG1VE   | 2D11/2D3AF1VE   |
|   | Type                        | Sirocco Fan   | Sirocco Fan   | Sirocco Fan   |
|   | Motor Output                | HP 0.21   | 0.36  | 0.58  |
|   | Air Flow Rate (H/L)         | cfm 690/565   | 1,020/810   | 1,270/1,020   |
|   | External Static Pressure ★4 | in. Aq 0.66-0.43  | 0.71-0.43   | 1.0-0.72  |
|   | Drive                       | Direct Drive  | Direct Drive  | Direct Drive  |
| Temperature Control                         |                             | Microprocessor Thermostat for Cooling and Heating   | Microprocessor Thermostat for Cooling and Heating   | Microprocessor Thermostat for Cooling and Heating   |
| Sound Absorbing Thermal Insulation Material |                             | Glass Fiber   | Glass Fiber   | Glass Fiber   |
| Air Filter                                  |                             | ★5  | ★5  | ★5  |
| Piping Connections                          | Liquid Pipes                | in $\phi$ 3/8 (Flare Connection)  | $\phi$ 3/8 (Flare Connection)   | $\phi$ 3/8 (Flare Connection)   |
|   | Gas Pipes                   | in $\phi$ 5/8 (Flare Connection)  | $\phi$ 5/8 (Flare Connection)   | $\phi$ 5/8 (Flare Connection)   |
|   | Drain Pipe                  | in VP25 ( External Dia. 1-1/4 ) Internal Dia. 1   | VP25 ( External Dia. 1-1/4 ) Internal Dia. 1  | VP25 ( External Dia. 1-1/4 ) Internal Dia. 1  |
| Machine Weight (Mass)                       | Lbs                         | 99  | 139   | 144   |
| ★6 Sound Level (H/L)                        | dBA                         | 45/41   | 45/41   | 48/45   |
| Safety Devices                              |                             | Fuse, Thermal Fuse for Fan Motor  | Fuse, Thermal Fuse for Fan Motor  | Fuse, Thermal Fuse for Fan Motor  |
| Refrigerant Control                         |                             | Electronic Expansion Valve  | Electronic Expansion Valve  | Electronic Expansion Valve  |
| Connectable outdoor unit                    |                             | R-410A Series   | R-410A Series   | R-410A Series   |
| Standard Accessories                        |                             | Operation Manual, Installation Manual, Drain Hose, Clamp Metal, Insulation for Fitting, Sealing Pads, Clamps, Screws. | Operation Manual, Installation Manual, Drain Hose, Clamp Metal, Insulation for Fitting, Sealing Pads, Clamps, Screws. | Operation Manual, Installation Manual, Drain Hose, Clamp Metal, Insulation for Fitting, Sealing Pads, Clamps, Screws. |
| Drawing No.                                 |                             | C:3D042685  |   |   |

**Notes:**

- ★1 Nominal cooling capacities are based on the following conditions:  
Return air temperature: 80°FDB, 67°FWB  
Outdoor temperature: 95°FDB  
Equivalent ref. piping length: 25ft (Horizontal)
- ★2 Nominal heating capacities are based on the following conditions:  
Return air temperature: 70°FDB.  
Outdoor temperature: 47°FDB, 43°FWB  
Equivalent ref. piping length: 25ft (Horizontal)
- 3 Capacities are net, including a deduction for cooling (an addition for heating) for indoor fan motor heat.
- ★4 External static pressure is changeable to change over the connectors inside electrical box, this pressure means "High static pressure – Standard".
- ★5 Air filter is not standard accessory, but please mount it in the duct system of the suction side.  
Select its colorimetric method (gravity method) 50% or more.
- ★6 Anechoic chamber conversion value, measured under JISB8616 conditions. During actual operation, these values are normally somewhat higher as a result of installation conditions.

**Ceiling Suspended Type**

| Model                                       |                     |                 | FXHQ12MVJU   | FXHQ24MVJU   | FXHQ36MVJU   |
|---|---------------------|-----------------|--|--|--|
| ★1 Cooling Capacity                         | Btu/h               |                 | 12,000   | 24,000   | 36,000   |
| ★2 Heating Capacity                         | Btu/h               |                 | 13,500   | 27,000   | 40,000   |
| Casing / Color                              |                     |                 | White(10Y9/0.5)  | White(10Y9/0.5)  | White(10Y9/0.5)  |
| Dimensions: (HxWxD)                         |                     | in              | 7-11/16 x 37-13/16 x 26-3/4  | 7-11/16 x 55-1/8 x 26-3/4  | 7-11/16 x 62-5/8 x 26-3/4  |
| Coil (Cross Fin Coil)                       | Rows x Stages x FPI |                 | 2x12x15  | 3x12x15  | 2x12x15+2x10x15  |
|   | Face Area           | ft <sup>2</sup> | 1.96   | 3.15   | 3.66+2.95  |
| Fan   | Model               |                 | 3D12K1AA1  | 3D12K2AA1  | —  |
|   | Type                |                 | Sirocco Fan  | Sirocco Fan  | Sirocco Fan  |
|   | Motor Output        | W               | 62   | 130  | 130  |
|   | Air Flow Rate (H/L) | cfm             | 410/340  | 710/600  | 830/670  |
|   | Drive               |                 | Direct Drive   | Direct Drive   | Direct Drive   |
| Temperature Control                         |                     |                 | Microprocessor Thermostat for Cooling and Heating  | Microprocessor Thermostat for Cooling and Heating  | Microprocessor Thermostat for Cooling and Heating  |
| Sound Absorbing Thermal Insulation Material |                     |                 | Glass Wool   | Glass Wool   | Glass Wool   |
| Air Filter                                  |                     |                 | Resin Net (with Mold Resistant)  |  |  |
| Piping Connections                          | Liquid Pipes        | in              | φ1/4 (Flare Connection)  | φ3/8 (Flare Connection)  | φ3/8 (Flare Connection)  |
|   | Gas Pipes           | in              | φ1/2 (Flare Connection)  | φ5/8 (Flare Connection)  | φ5/8 (Flare Connection)  |
|   | Drain Pipes         | in              | VP20<br>(External Dia. 1<br>Internal Dia. 3/4)   | VP20<br>(External Dia. 1<br>Internal Dia. 3/4)   | VP20<br>(External Dia. 1<br>Internal Dia. 3/4)   |
| Machine Weight (Mass)                       | Lbs                 |                 | 55   | 80   | 90   |
| ★4 Sound Level (H/L)                        | dBA                 |                 | 42   | 44   | 46   |
| Safety Devices                              |                     |                 | Fuse,<br>Thermal Protector for Fan Motor   | Fuse,<br>Thermal Protector for Fan Motor   | Fuse,<br>Thermal Protector for Fan Motor   |
| Refrigerant Control                         |                     |                 | Electronic Expansion Valve   | Electronic Expansion Valve   | Electronic Expansion Valve   |
| Connectable Outdoor Unit                    |                     |                 | R-410A Series  | R-410A Series  | R-410A Series  |
| Standard Accessories                        |                     |                 | Operation Manual, Installation Manual, Drain Hose, Paper Pattern for Installation, Clamp Metal, Insulation for Fitting, Clamps, Washers. | Operation Manual, Installation Manual, Drain Hose, Paper Pattern for Installation, Clamp Metal, Insulation for Fitting, Clamps, Washers. | Operation Manual, Installation Manual, Drain Hose, Paper Pattern for Installation, Clamp Metal, Insulation for Fitting, Clamps, Washers. |
| Drawing No.                                 |                     |                 | C:4D049326   |  |  |

- Notes:**
- ★1 Nominal cooling capacities are based on the following conditions:  
 Return air temperature: 80°FDB, 67°FWB  
 Outdoor temperature: 95°FDB  
 Equivalent ref. piping length: 25ft (Horizontal)
  - ★2 Nominal heating capacities are based on the following conditions:  
 Return air temperature: 70°FDB.  
 Outdoor temperature: 47°FDB, 43°FWB  
 Equivalent ref. piping length: 25ft (Horizontal)
  - 3 Capacities are net, including a deduction for cooling (an addition for heating) for indoor fan motor heat.
  - ★4 Anechoic chamber conversion value, measured under JISB8616 conditions. During actual operation, these values are normally somewhat higher as a result of installation conditions.

## Wall Mounted Type

| Model                                       |                     |                 | FXAQ07MVJU  | FXAQ09MVJU  | FXAQ12MVJU  |
|---|---------------------|-----------------|---|---|---|
| ★1 Cooling Capacity                         | Btu/h               |                 | 7,500   | 9,500   | 12,000  |
| ★2 Heating Capacity                         | Btu/h               |                 | 8,500   | 10,500  | 13,500  |
| Casing Color                                |                     |                 | White (3.0Y8.5/0.5)   | White (3.0Y8.5/0.5)   | White (3.0Y8.5/0.5)   |
| Dimensions: (HxWxD)                         |                     | in              | 11-3/8x31-1/4x9   | 11-3/8x31-1/4x9   | 11-3/8x31-1/4x9   |
| Coil (Cross Fin Coil)                       | Rows x Stages x FPI |                 | 2x14x17   | 2x14x17   | 2x14x17   |
|   | Face Area           | ft <sup>2</sup> | 1.73  | 1.73  | 1.73  |
| Fan   | Model               |                 | QCL9661M  | QCL9661M  | QCL9661M  |
|   | Type                |                 | Cross Flow Fan  | Cross Flow Fan  | Cross Flow Fan  |
|   | Motor Output        | HP              | 0.054   | 0.054   | 0.054   |
|   | Air Flow Rate (H/L) | cfm             | 260/160   | 280/175   | 300/180   |
|   | Drive               |                 | Direct Drive  | Direct Drive  | Direct Drive  |
| Temperature Control                         |                     |                 | Microprocessor Thermostat for Cooling and Heating   | Microprocessor Thermostat for Cooling and Heating   | Microprocessor Thermostat for Cooling and Heating   |
| Sound Absorbing Thermal Insulation Material |                     |                 | Foamed Polystyrene / Foamed Polyethylene  | Foamed Polystyrene / Foamed Polyethylene  | Foamed Polystyrene / Foamed Polyethylene  |
| Air Filter                                  |                     |                 | Resin Net (Washable)  | Resin Net (Washable)  | Resin Net (Washable)  |
| Piping Connections                          | Liquid Pipes        | in              | φ1/4 (Flare Connection)   | φ1/4 (Flare Connection)   | φ1/4 (Flare Connection)   |
|   | Gas Pipes           | in              | φ1/2 (Flare Connection)   | φ1/2 (Flare Connection)   | φ1/2 (Flare Connection)   |
|   | Drain Pipe          | in              | VP13<br>(External Dia. 11/16 Internal Dia. 1/2)   | VP13<br>(External Dia. 11/16 Internal Dia. 1/2)   | VP13<br>(External Dia. 11/16 Internal Dia. 1/2)   |
| Machine Weight (Mass)                       | Lbs                 |                 | 25  | 25  | 25  |
| ★4 Sound Level (H)                          | dBA                 |                 | 36  | 37  | 38  |
| Safety Devices                              |                     |                 | Fuse  | Fuse  | Fuse  |
| Refrigerant Control                         |                     |                 | Electronic Expansion Valve  | Electronic Expansion Valve  | Electronic Expansion Valve  |
| Connectable outdoor unit                    |                     |                 | R-410A Series   | R-410A Series   | R-410A Series   |
| Standard Accessories                        |                     |                 | Operation Manual, Installation Manual, Installation Panel, Paper Pattern for Installation, Insulation Tube, Clamps, Screws. | Operation Manual, Installation Manual, Installation Panel, Paper Pattern for Installation, Insulation Tube, Clamps, Screws. | Operation Manual, Installation Manual, Installation Panel, Paper Pattern for Installation, Insulation Tube, Clamps, Screws. |
| Drawing No.                                 |                     |                 | C:3D046038A   |   |   |

**Notes:**

- ★1 Nominal cooling capacities are based on the following conditions:  
Return air temperature: 80°FDB, 67°FWB  
Outdoor temperature: 95°FDB  
Equivalent ref. piping length: 25ft (Horizontal)
- ★2 Nominal heating capacities are based on the following conditions:  
Return air temperature: 70°FDB.  
Outdoor temperature: 47°FDB, 43°FWB  
Equivalent ref. piping length: 25ft (Horizontal)
- 3 Capacities are net, including a deduction for cooling (an addition for heating) for indoor fan motor heat.
- ★4 Anechoic chamber conversion value, measured under JISB8616 conditions. During actual operation, these values are normally somewhat higher as a result of installation conditions.

Wall Mounted Type

| Model                                       |                     |                 | FXAQ18MVJU  | FXAQ24MVJU  |
|---|---------------------|-----------------|---|---|
| ★1 Cooling Capacity                         | Btu/h               |                 | 18,000  | 24,000  |
| ★2 Heating Capacity                         | Btu/h               |                 | 20,000  | 27,000  |
| Casing Color                                |                     |                 | White (3.0Y8.5/0.5)   | White (3.0Y8.5/0.5)   |
| Dimensions: (HxWxD)                         |                     | in              | 11-3/8x41-3/8x9   | 11-3/8x41-3/8x9   |
| Coil (Cross Fin Coil)                       | Rows x Stages x FPI |                 | 2x14x17   | 2x14x17   |
|   | Face Area           | ft <sup>2</sup> | 2.29  | 2.29  |
| Fan   | Model               |                 | QCL9686   | QCL9686   |
|   | Type                |                 | Cross Flow Fan  | Cross Flow Fan  |
|   | Motor Output        | HP              | 0.058   | 0.058   |
|   | Air Flow Rate (H/L) | cfm             | 500/400   | 635/470   |
| Drive                                       |                     |                 | Direct Drive  | Direct Drive  |
| Temperature Control                         |                     |                 | Microprocessor Thermostat for Cooling and Heating   | Microprocessor Thermostat for Cooling and Heating   |
| Sound Absorbing Thermal Insulation Material |                     |                 | Foamed Polystyrene / Foamed Polyethylene  | Foamed Polystyrene / Foamed Polyethylene  |
| Air Filter                                  |                     |                 | Resin Net (Washable)  | Resin Net (Washable)  |
| Piping Connections                          | Liquid Pipes        | in              | ϕ1/4 (Flare Connection)   | ϕ3/8 (Flare Connection)   |
|   | Gas Pipes           | in              | ϕ1/2 (Flare Connection)   | ϕ5/8 (Flare Connection)   |
|   | Drain Pipe          | in              | VP13<br>(External Dia. 11/16 Internal Dia. 1/2)   | VP13<br>(External Dia. 11/16 Internal Dia. 1/2)   |
| Machine Weight (Mass)                       | Lbs                 |                 | 31  | 31  |
| ★4 Sound Level (H)                          | dBA                 |                 | 43  | 47  |
| Safety Devices                              |                     |                 | Fuse  | Fuse  |
| Refrigerant Control                         |                     |                 | Electronic Expansion Valve  | Electronic Expansion Valve  |
| Connectable outdoor unit                    |                     |                 | R-410A Series   | R-410A Series   |
| Standard Accessories                        |                     |                 | Operation Manual, Installation Manual, Installation Panel, Paper Pattern for Installation, Insulation Tube, Clamps, Screws. | Operation Manual, Installation Manual, Installation Panel, Paper Pattern for Installation, Insulation Tube, Clamps, Screws. |
| Drawing No.                                 |                     |                 | C:3D046038A   |   |

Notes:

- ★1 Nominal cooling capacities are based on the following conditions:  
Return air temperature: 80°FDB, 67°FWB  
Outdoor temperature: 95°FDB  
Equivalent ref. piping length: 25ft (Horizontal)
- ★2 Nominal heating capacities are based on the following conditions:  
Return air temperature: 70°FDB.  
Outdoor temperature: 47°FDB, 43°FWB  
Equivalent ref. piping length: 25ft (Horizontal)
- 3 Capacities are net, including a deduction for cooling (an addition for heating) for indoor fan motor heat.
- ★4 Anechoic chamber conversion value, measured under JISB8616 conditions. During actual operation, these values are normally somewhat higher as a result of installation conditions.

## Floor Standing Type

| Model                                       |                     | FXLQ12MVJU  | FXLQ18MVJU  | FXLQ24MVJU  |
|---|---------------------|---|---|---|
| ★1 Cooling Capacity                         | Btu/h               | 12,000  | 18,000  | 24,000  |
| ★2 Heating Capacity                         | Btu/h               | 13,500  | 20,000  | 27,000  |
| Casing Color                                |                     | Ivory White (5Y7.5/1)   | Ivory White (5Y7.5/1)   | Ivory White (5Y7.5/1)   |
| Dimensions: (HxWxD)                         |                     | 23-5/8x44-7/8x8-3/4   | 23-5/8x55-7/8x8-3/4   | 23-5/8x55-7/8x8-3/4   |
| Coil (Cross Fin Coil)                       | Rows x Stages x FPI | 3x14x17   | 3x14x17   | 3x14x17   |
|   | Face Area           | ft <sup>2</sup>   | 2.15  | 3.04  |
| Fan   | Model               | 2D14B13   | 2D14B20   | 2D14B20   |
|   | Type                | Sirocco Fan   | Sirocco Fan   | Sirocco Fan   |
|   | Motor Output        | HP  | 0.034   | 0.047   |
|   | Air Flow Rate (H/L) | cfm   | 280/210   | 490/380   |
|   | Drive               | Direct Drive  | Direct Drive  | Direct Drive  |
| Temperature Control                         |                     | Microprocessor Thermostat for Cooling and Heating   | Microprocessor Thermostat for Cooling and Heating   | Microprocessor Thermostat for Cooling and Heating   |
| Sound Absorbing Thermal Insulation Material |                     | Glass Fiber/ Urethane Foam  | Glass Fiber/ Urethane Foam  | Glass Fiber/ Urethane Foam  |
| Air Filter                                  |                     | Resin Net (with Mold Resistant)   | Resin Net (with Mold Resistant)   | Resin Net (with Mold Resistant)   |
| Piping Connections                          | Liquid Pipes        | in  | φ1/4 (Flare Connection)   | φ3/8 (Flare Connection)   |
|   | Gas Pipes           | in  | φ1/2 (Flare Connection)   | φ5/8 (Flare Connection)   |
|   | Drain Pipe          | in  | φ27/32 O.D (Vinyl Chloride)   | φ27/32 O.D (Vinyl Chloride)   |
| Machine Weight (Mass)                       | Lbs                 | 66  | 80  | 80  |
| ★4 Sound Level (H/L)                        | dBA                 | 36  | 40  | 41  |
| Safety Devices                              |                     | Fuse, Thermal Protector for Fan Motor   | Fuse, Thermal Protector for Fan Motor   | Fuse, Thermal Protector for Fan Motor   |
| Refrigerant Control                         |                     | Electronic Expansion Valve  | Electronic Expansion Valve  | Electronic Expansion Valve  |
| Connectable Outdoor Unit                    |                     | R-410A Series   | R-410A Series   | R-410A Series   |
| Standard Accessories                        |                     | Operation Manual, Installation Manual, Insulation for Fitting, Drain Hose, Clamps, Screws, Washers, Level Adjustment Screw. | Operation Manual, Installation Manual, Insulation for Fitting, Drain Hose, Clamps, Screws, Washers, Level Adjustment Screw. | Operation Manual, Installation Manual, Insulation for Fitting, Drain Hose, Clamps, Screws, Washers, Level Adjustment Screw. |
| Drawing No.                                 |                     | 3D045640  |   |   |

### Notes:

- ★1 Nominal cooling capacities are based on the following conditions:  
Return air temperature: 80°FDB, 67°FWB  
Outdoor temperature: 95°FDB  
Equivalent ref. piping length: 25ft (Horizontal)
- ★2 Nominal heating capacities are based on the following conditions:  
Return air temperature: 70°FDB.  
Outdoor temperature: 47°FDB, 43°FWB  
Equivalent ref. piping length: 25ft (Horizontal)
- 3 Capacities are net, including a deduction for cooling (an addition for heating) for indoor fan motor heat.
- ★4 Anechoic chamber conversion value, measured under JISB8616 conditions. During actual operation, these values are normally somewhat higher as a result of installation conditions.



## Concealed Floor Standing Type

| Model                                       |                     | FXNQ12MVJU  | FXNQ18MVJU  | FXNQ24MVJU  |
|---|---------------------|---|---|---|
| ★1 Cooling Capacity                         | Btu/h               | 12,000  | 18,000  | 24,000  |
| ★2 Heating Capacity                         | Btu/h               | 13,500  | 20,000  | 27,000  |
| Casing Color                                |                     | Galvanized Steel Plate  | Galvanized Steel Plate  | Galvanized Steel Plate  |
| Dimensions: (HxWxD)                         |                     | in  | 24x42-1/8x8-5/8   | 24x53-1/8x8-5/8   |
| Coil (Cross Fin Coil)                       | Rows x Stages x FPI | 3x14x17   | 3x14x17   | 3x14x17   |
|   | Face Area           | ft <sup>2</sup>   | 2.15  | 3.04  |
| Fan   | Model               | 2D14B13   | 2D14B20   | 2D14B20   |
|   | Type                | Sirocco Fan   | Sirocco Fan   | Sirocco Fan   |
|   | Motor Output        | HP  | 0.034   | 0.047   |
|   | Air Flow Rate (H/L) | cfm   | 280/210   | 490/380   |
|   | Drive               | Direct Drive  | Direct Drive  | Direct Drive  |
| Temperature Control                         |                     | Microprocessor Thermostat for Cooling and Heating   | Microprocessor Thermostat for Cooling and Heating   | Microprocessor Thermostat for Cooling and Heating   |
| Sound Absorbing Thermal Insulation Material |                     | Glass Fiber/ Urethane Foam  | Glass Fiber/ Urethane Foam  | Glass Fiber/ Urethane Foam  |
| Air Filter                                  |                     | Resin Net (with Mold Resistant)   | Resin Net (with Mold Resistant)   | Resin Net (with Mold Resistant)   |
| Piping Connections                          | Liquid Pipes        | in  | φ1/4 (Flare Connection)   | φ3/8 (Flare Connection)   |
|   | Gas Pipes           | in  | φ1/2 (Flare Connection)   | φ5/8 (Flare Connection)   |
|   | Drain Pipe          | in  | φ27/32 O.D (Vinyl Chloride)   | φ27/32 O.D (Vinyl Chloride)   |
| Machine Weight (Mass)                       | Lbs                 | 66  | 80  | 80  |
| ★4 Sound Level (H/L)                        | dBA                 | 36  | 40  | 41  |
| Safety Devices                              |                     | Fuse, Thermal Protector for Fan Motor   | Fuse, Thermal Protector for Fan Motor   | Fuse, Thermal Protector for Fan Motor   |
| Refrigerant Control                         |                     | Electronic Expansion Valve  | Electronic Expansion Valve  | Electronic Expansion Valve  |
| Connectable Outdoor Unit                    |                     | R-410A Series   | R-410A Series   | R-410A Series   |
| Standard Accessories                        |                     | Operation Manual, Installation Manual, Insulation for Fitting, Drain Hose, Clamps, Screws, Washers, Level Adjustment Screw. | Operation Manual, Installation Manual, Insulation for Fitting, Drain Hose, Clamps, Screws, Washers, Level Adjustment Screw. | Operation Manual, Installation Manual, Insulation for Fitting, Drain Hose, Clamps, Screws, Washers, Level Adjustment Screw. |
| Drawing No.                                 |                     | 3D045640  |   |   |

**Notes:**

- ★1 Nominal cooling capacities are based on the following conditions:  
Return air temperature: 80°FDB, 67°FWB  
Outdoor temperature: 95°FDB  
Equivalent ref. piping length: 25ft (Horizontal)
- ★2 Nominal heating capacities are based on the following conditions:  
Return air temperature: 70°FDB.  
Outdoor temperature: 47°FDB, 43°FWB  
Equivalent ref. piping length: 25ft (Horizontal)
- 3 Capacities are net, including a deduction for cooling (an addition for heating) for indoor fan motor heat.
- ★4 Anechoic chamber conversion value, measured under JISB8616 conditions. During actual operation, these values are normally somewhat higher as a result of installation conditions.

# Part 3

# Refrigerant Circuit

|  |    |
|--|----|
| 1. Refrigerant Circuit .....                     | 24 |
| 1.1 RXYQ72M, 96M .....                           | 24 |
| 2. Functional Parts Layout .....                 | 26 |
| 2.1 RXYQ72M, 96M .....                           | 26 |
| 3. Refrigerant Flow for Each Operation Mode..... | 27 |

# 1. Refrigerant Circuit

## 1.1 RXYQ72M, 96M

| No. in refrigerant system diagram | Symbol | Name  | Major Function  |
|-----------------------------------|--------|---|---|
| A                                 | M1C    | Inverter compressor (INV)                                       | Inverter compressor is operated on frequencies between 52 Hz and 210 Hz by using the inverter, while Standard compressor is operated with commercial power supply only. The number of operating steps is as follows when Inverter compressor is operated in combination with Standard compressor. |
| B                                 | M2C    | Standard compressor 1 (STD1)                                    |   |
| D                                 | M1F    | Inverter fan  | Since the system is of air heat exchanging type, the fan is operated at 8-step rotation speed by using the inverter.  |
| E                                 | Y1E    | Electronic expansion valve (Main: EV1)                          | While in heating operation, PI control is applied to keep the outlet superheated degree of air heat exchanger constant.   |
| F                                 | Y2E    | Electronic expansion valve (Subcool: EV2)                       | PI control is applied to keep the outlet superheated degree of subcooling heat exchanger constant.  |
| G                                 | Y1S    | Solenoid valve (Hot gas: SVP)                                   | Used to prevent the low pressure from transient falling.  |
| H                                 | Y2S    | Solenoid valve (Oil equalization: SVO)                          | Used for oil equalizing among outdoor units in multiple-outdoor-unit system.  |
| I                                 | Y3S    | Solenoid valve (Receiver gas charging: SVL)                     | Used to maintain high pressure while in cooling operation at low outdoor temperature. And also used to prevent the accumulation of refrigerant in non-operating outdoor units in the case of multiple-outdoor-unit system.  |
| J                                 | Y4S    | Solenoid valve (Receiver gas discharging: SV)                   | Used to collect refrigerant to receiver.  |
| K                                 | Y5S    | Solenoid valve (Non-operating unit gas discharging SVSG)        | Used to prevent the accumulation of refrigerant in non-operating outdoor units in the case of multiple-outdoor-unit system.   |
| L                                 | Y6S    | Solenoid valve (Non-operating unit liquid pipe closing: SVSL)   | Used to prevent the accumulation of refrigerant in non-operating outdoor units in the case of multi-outdoor unit system.  |
| M                                 | Y7S    | 4-way valve   | Used to switch the operation mode between cooling and heating.  |
| N                                 | S1NPH  | High pressure sensor  | Used to detect high pressure.   |
| O                                 | S1NPL  | Low pressure sensor   | Used to detect low pressure.  |
| P                                 | S1PH   | HP pressure switch (For INV compressor)                         | In order to prevent the increase of high pressure when a malfunction occurs, this switch is activated at high pressure of 550 psi or more to stop the compressor operation.   |
| Q                                 | S2PH   | HP pressure switch (For STD compressor 2)                       |   |
| S                                 | —      | Fusible plug  | In order to prevent the increase of pressure when abnormal heating is caused by fire or others, the fusible part of the plug is molten at a temperature of 158 to 167°F to release the pressure into the atmosphere.  |
| T                                 | —      | Pressure regulating valve 1 (Receiver to discharge pipe)        | This valve opens at a pressure of 290 to 390 psi for prevention of pressure increase, thus resulting in no damage of functional parts due to the increase of pressure in transportation or storage.   |
| U                                 | —      | Pressure regulating valve 2 (Liquid pipe to receiver)           |   |
| V                                 | —      | Pressure regulating valve 3 (Equalizing pipe to discharge pipe) |   |
| 1                                 | R1T    | Thermistor (Outdoor air: Ta)                                    | Used to detect outdoor temperature, correct discharge pipe temperature, and others.   |
| 2                                 | R2T    | Thermistor (Suction pipe: Ts)                                   | used to detect suction pipe temperature, keep the suction superheated degree constant in heating operation, and others.   |
| 3                                 | R31T   | Thermistor (INV discharge pipe: Tdi)                            | used to detect discharge pipe temperature, make the temperature protection control of compressor, and others.   |
| 4                                 | R32T   | Thermistor (STD1 discharge pipe: Tds1)                          |   |
| 6                                 | R4T    | Thermistor (Heat exchanger deicer: Tb)                          | Used to detect liquid pipe temperature of air heat exchanger, determine defrosting operation, and others.   |
| 7                                 | R5T    | Thermistor (Subcooling heat exchanger gas pipe: Tsh)            | Used to detect gas pipe temperature on the evaporation side of subcooling heat exchanger, keep the superheated degree at the outlet of subcooling heat exchanger constant, and others.  |
| 8                                 | R6T    | Thermistor (Receiver outlet liquid pipe: TI)                    | Used to detect receiver outlet liquid pipe temperature, prevent the drift between outdoor units while in heating operation in the case of multiple-outdoor-unit system, and others.   |
| 9                                 | R7T    | Thermistor (Oil equalizing pipe: To)                            | Used to detect equalizing pipe temperature, opening/closing of the equalizing pipe stop valve, and others.  |

RXYQ72M, 96M

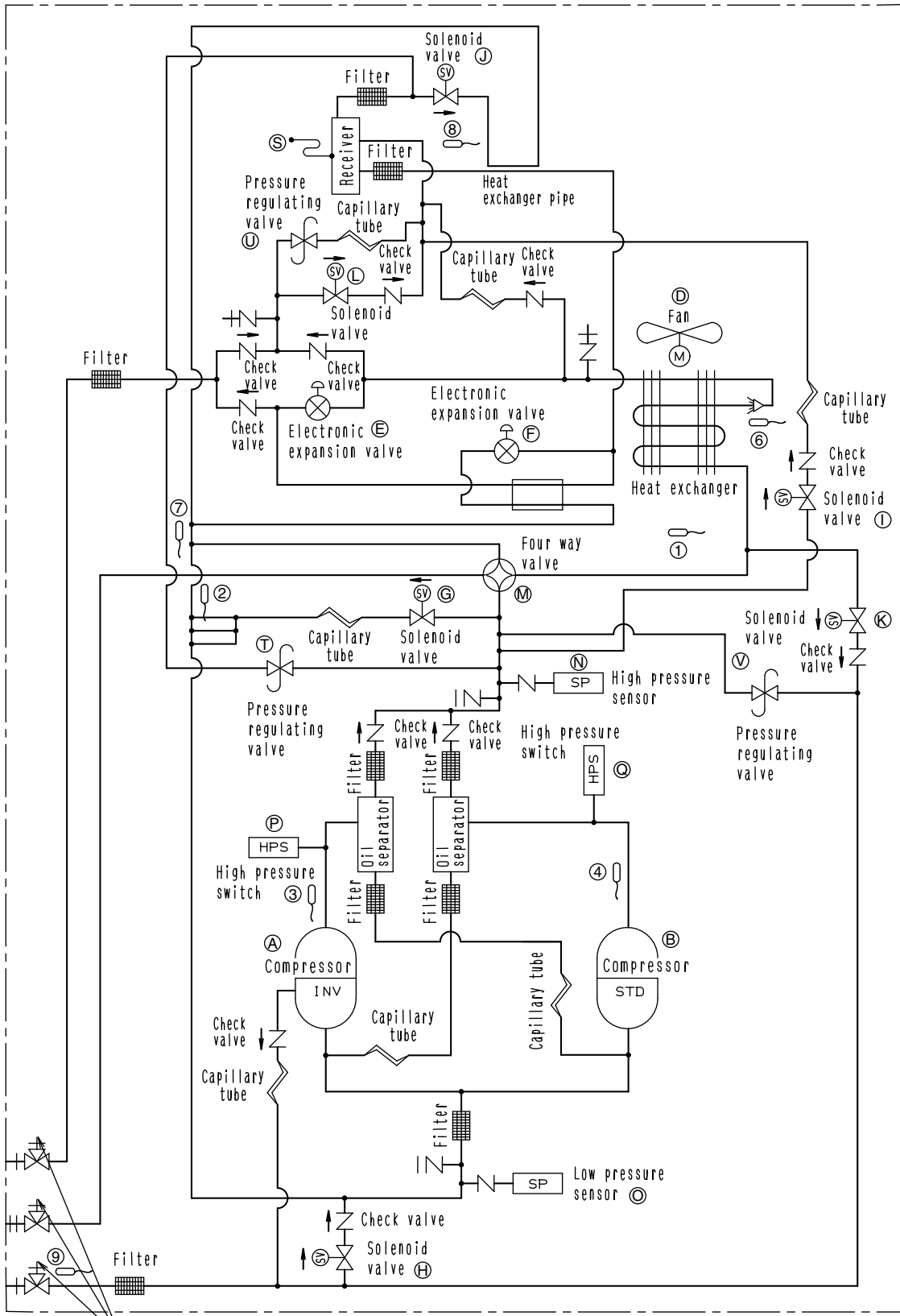

Stop valve (With service port on on-site piping side  $\phi 5/16$  flare connection)

4D042651A

## 2. Functional Parts Layout

### 2.1 RXYQ72M, 96M

#### Plan

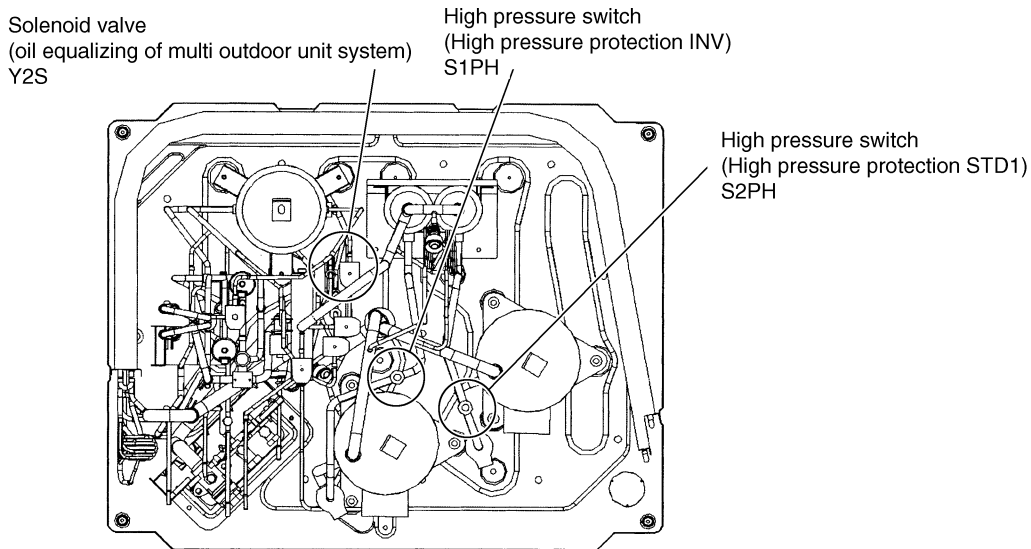

#### Front View

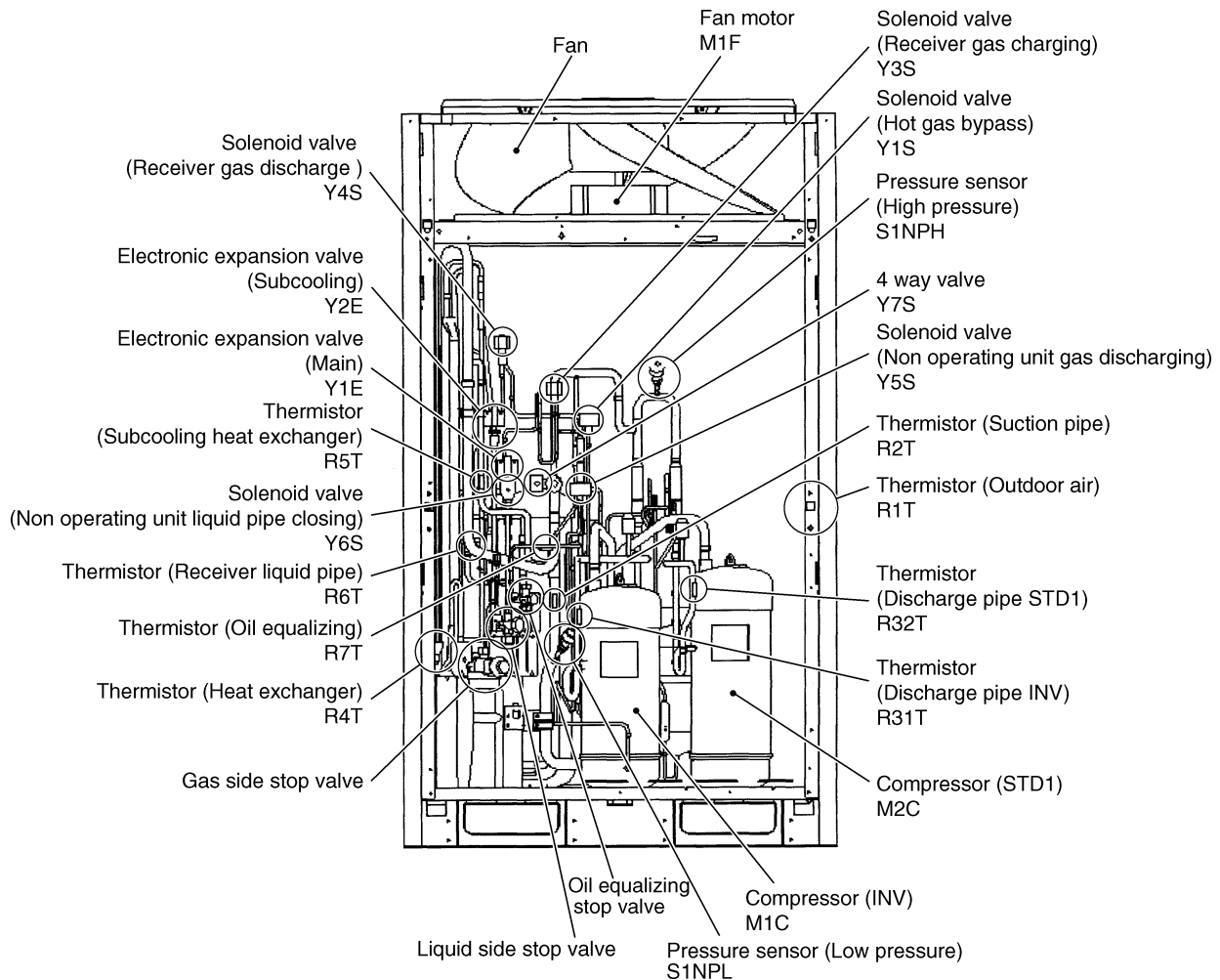

# 3. Refrigerant Flow for Each Operation Mode

**RXYQ72M, 96M**  
**Cooling Operation**

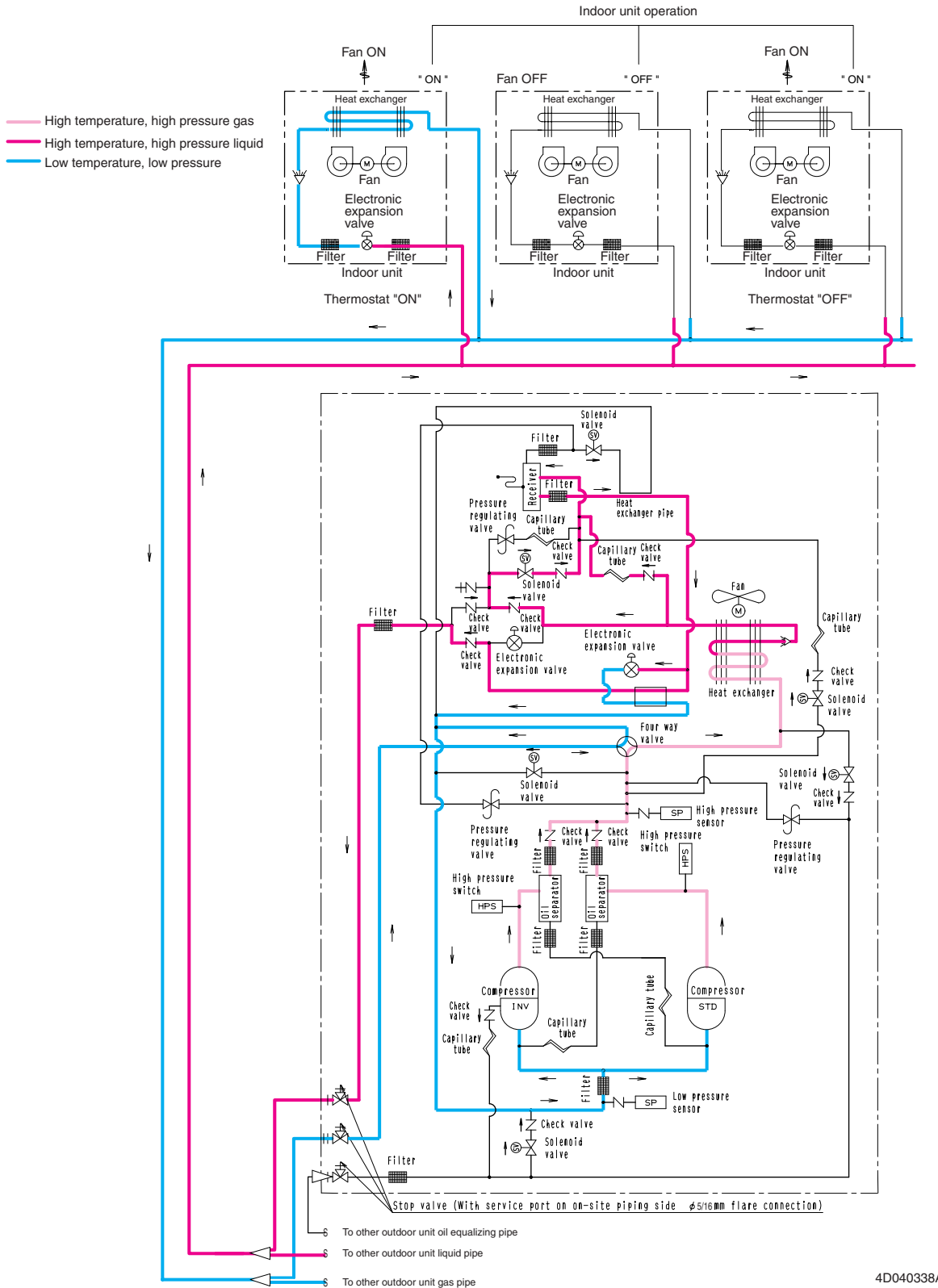

Cooling Oil Return

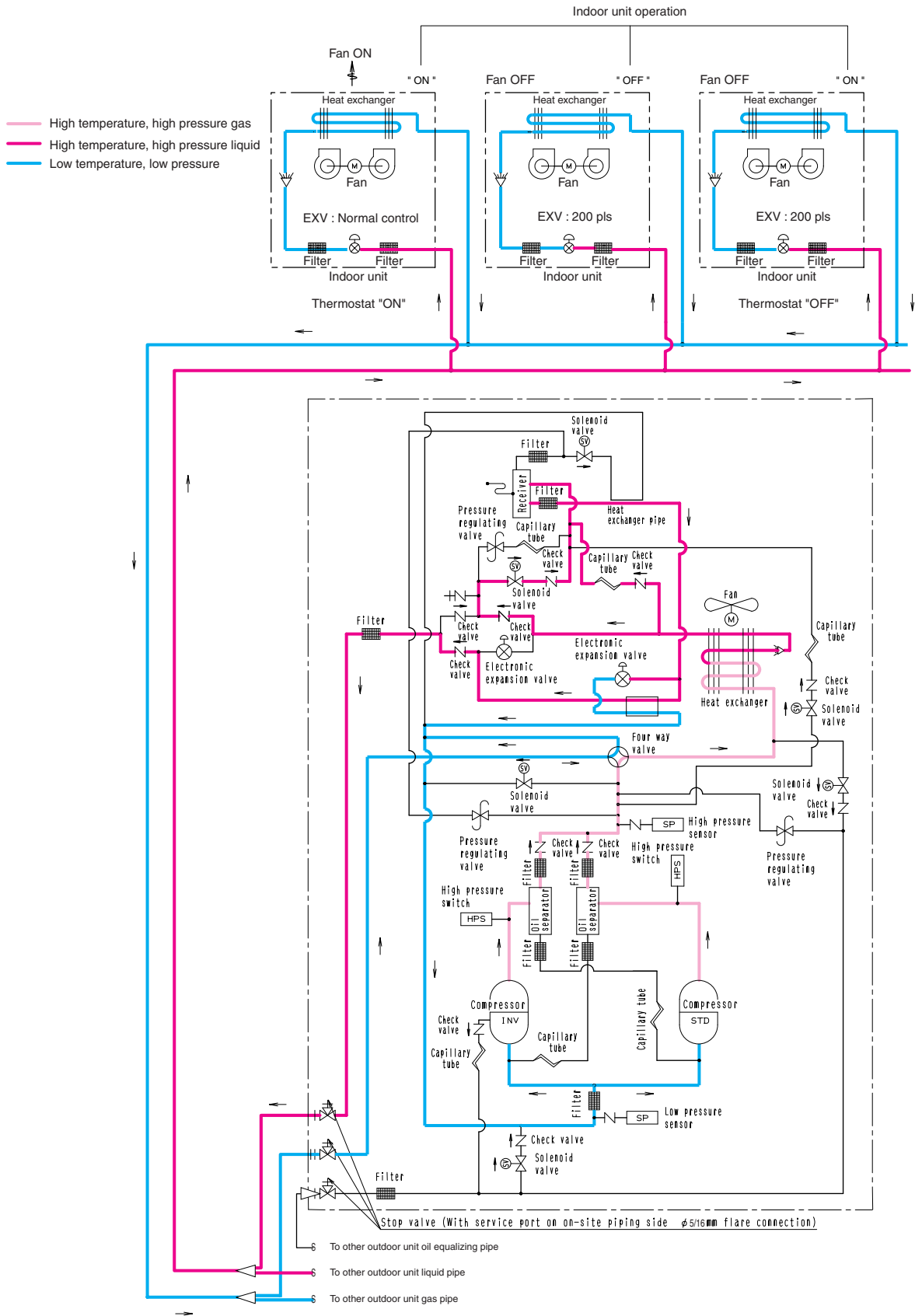

4D040338A

### Heating Oil Return & Defrost

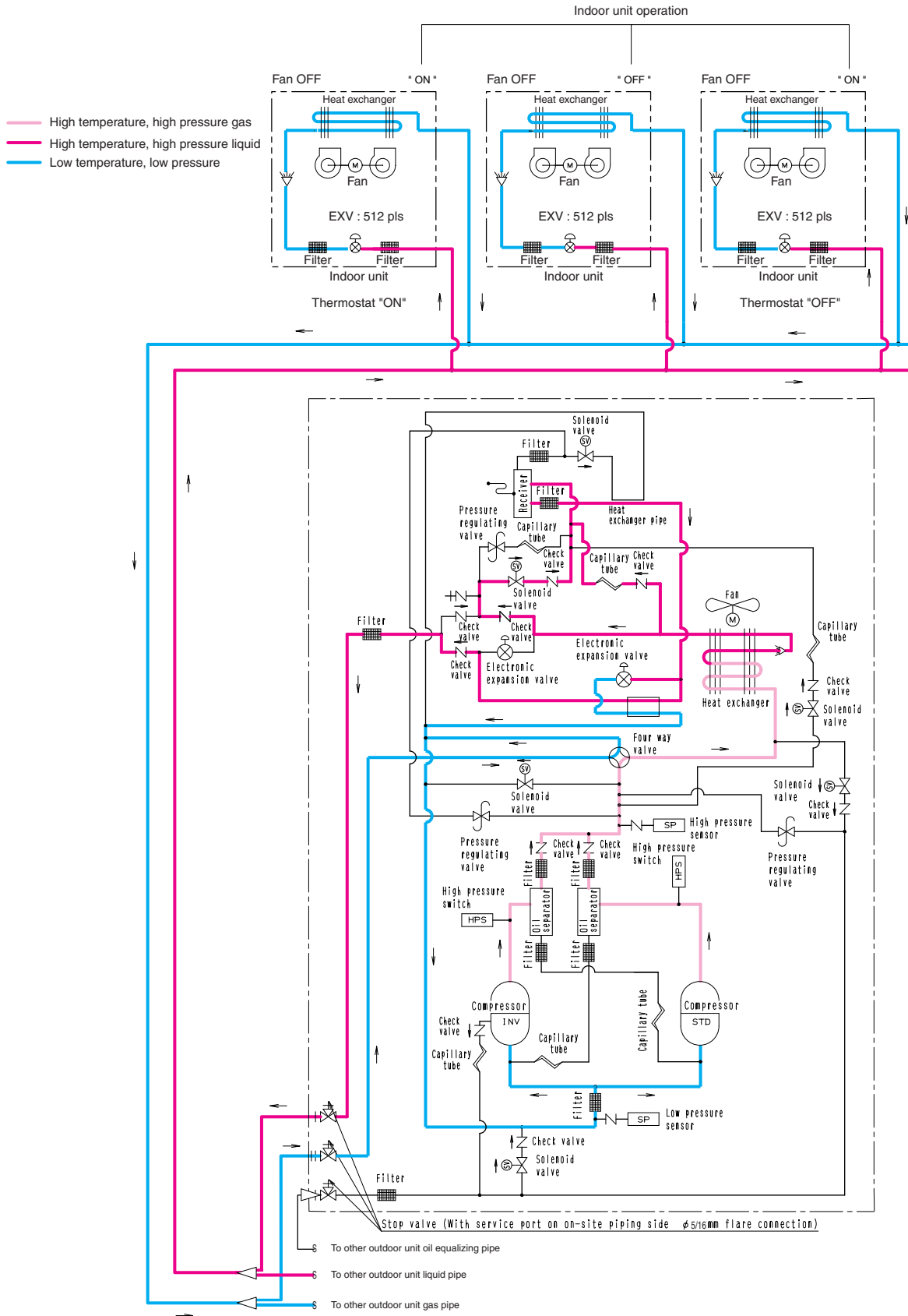

4D040338A



Heating Operation

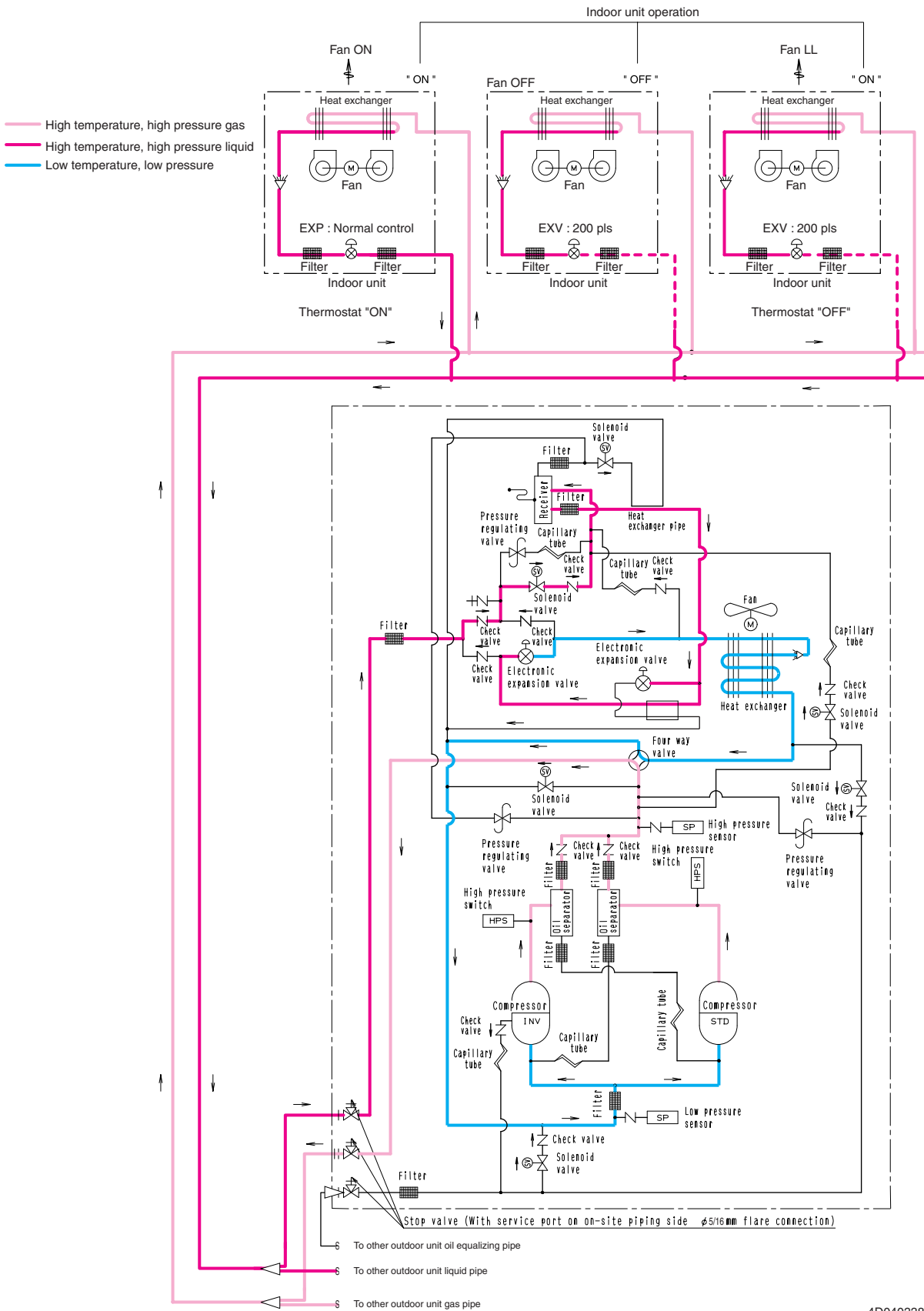

4D040338A

# Part 4

## Function

|   |    |
|---|----|
| 1. Operation Mode .....                         | 32 |
| 2. Basic Control.....                           | 33 |
| 2.1 Normal Operation .....                      | 33 |
| 2.2 Compressor PI Control.....                  | 34 |
| 2.3 Electronic Expansion Valve PI Control.....  | 38 |
| 2.4 Cooling Operation Fan Control.....          | 39 |
| 3. Special Control.....                         | 40 |
| 3.1 Startup Control .....                       | 40 |
| 3.2 Oil Return Operation .....                  | 41 |
| 3.3 Defrosting Operation .....                  | 43 |
| 3.4 Pump-down Residual Operation .....          | 44 |
| 3.5 Restart Standby.....                        | 45 |
| 3.6 Stopping Operation .....                    | 46 |
| 3.7 Pressure Equalization prior to Startup..... | 48 |
| 4. Protection Control .....                     | 49 |
| 4.1 High Pressure Protection Control.....       | 49 |
| 4.2 Low Pressure Protection Control.....        | 50 |
| 4.3 Discharge Pipe Protection Control .....     | 51 |
| 4.4 Inverter Protection Control .....           | 52 |
| 4.5 STD Compressor Overload Protection.....     | 53 |
| 5. Other Control.....                           | 54 |
| 5.1 Outdoor Unit Rotation.....                  | 54 |
| 5.2 Emergency Operation .....                   | 55 |
| 5.3 Demand Operation .....                      | 57 |
| 5.4 Heating Operation Prohibition .....         | 57 |
| 6. Outline of Control (Indoor Unit) .....       | 58 |
| 6.1 Drain Pump Control.....                     | 58 |
| 6.2 Thermostat Sensor in Remote Controller..... | 60 |
| 6.3 Freeze Prevention .....                     | 62 |

# 1. Operation Mode

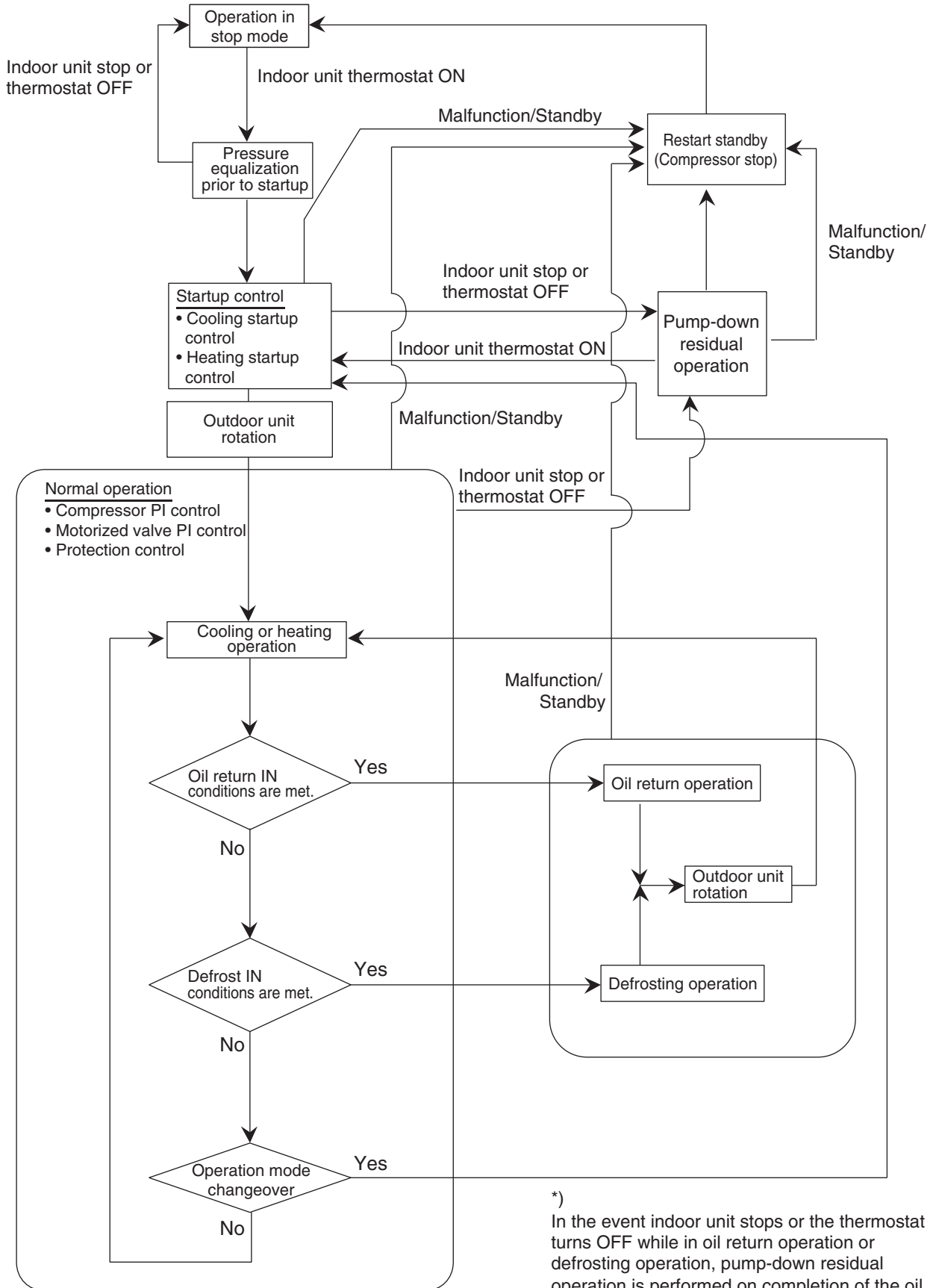

\*) In the event indoor unit stops or the thermostat turns OFF while in oil return operation or defrosting operation, pump-down residual operation is performed on completion of the oil return operation or defrosting operation.

## 2. Basic Control

### 2.1 Normal Operation

#### ■ Cooling Operation

| Actuator   | Operation             | Remarks   |
|--|-----------------------|---|
| Compressor                                       | Compressor PI control | Used for high pressure protection control, low pressure protection control, discharge pipe temperature protection control, and compressor operating frequency upper limit control with inverter protection control. |
| Outdoor unit fan                                 | Cooling fan control   | —   |
| Four way valve                                   | OFF                   | —   |
| Main motorized valve (EV1)                       | 0 pls                 | —   |
| Subcooling motorized valve (EV2)                 | PI control            | —   |
| Hot gas bypass valve (SVP)                       | OFF                   | This valve turns on with low pressure protection control.   |
| Oil equalization valve (SVO)                     | ON                    | In the case of multi-outdoor-unit system, this valve repeats ON/OFF operation at regular intervals of time.   |
| Receiver gas charging valve (SVL)                | OFF                   | This valve turns on when outdoor temperature is low.  |
| Receiver gas discharging valve (SVG)             | OFF                   | —   |
| Non-operating unit gas discharging valve (SVSG)  | OFF                   | —   |
| Non-operating unit liquid pipe stop valve (SVSL) | ON                    | —   |

#### ■ Heating Operation

| Actuator   | Operation             | Remarks   |
|--|-----------------------|---|
| Compressor                                       | Compressor PI control | Used for high pressure protection control, low pressure protection control, discharge pipe temperature protection control, and compressor operating frequency upper limit control with inverter protection control. |
| Outdoor unit fan                                 | STEP8 or 9            | —   |
| Four way valve                                   | ON                    | —   |
| Main motorized valve (EV1)                       | PI control            | —   |
| Subcooling motorized valve (EV2)                 | 0 pls                 | —   |
| Hot gas bypass valve (SVP)                       | OFF                   | This valve turns on with low pressure protection control.   |
| Oil equalization valve (SVO)                     | ON                    | In the case of multi-outdoor-unit system, this valve repeats ON/OFF operation at regular intervals of time.   |
| Receiver gas charging valve (SVL)                | OFF                   | —   |
| Receiver gas discharging valve (SVG)             | OFF                   | —   |
| Non-operating unit gas discharging valve (SVSG)  | OFF                   | —   |
| Non-operating unit liquid pipe stop valve (SVSL) | ON                    | —   |

★Heating operation is not functional at an outdoor air temperature of 75°F or more.

## 2.2 Compressor PI Control

### Compressor PI Control

Carries out the compressor capacity PI control to maintain  $T_e$  at constant during cooling operation and  $T_c$  at constant during heating operation to ensure stable unit performance.

#### [Cooling operation]

Controls compressor capacity to adjust  $T_e$  to achieve target value ( $T_eS$ ).

##### Te setting

| L    | M (Normal)<br>(factory setting) | H  |
|------|---------------------------------|----|
| 37.5 | 43                              | 48 |

$T_e$  : Low pressure equivalent saturation temperature (°F)

$T_eS$  : Target  $T_e$  value  
(Varies depending on  $T_e$  setting, operating frequency, etc.)

#### [Heating operation]

Controls compressor capacity to adjust  $T_c$  to achieve target value ( $T_cS$ ).

##### Tc setting

| L     | M (Normal)<br>(factory setting) | H   |
|-------|---------------------------------|-----|
| 109.5 | 115                             | 120 |

$T_c$  : High pressure equivalent saturation temperature (°F)

$T_cS$  : Target  $T_c$  value  
(Varies depending on  $T_c$  setting, operating frequency, etc.)

### ■ Compressor Operating Priority

Each compressor operates in the following order of priority.

INV: Inverter compressor

STD1: Standard compressor 1

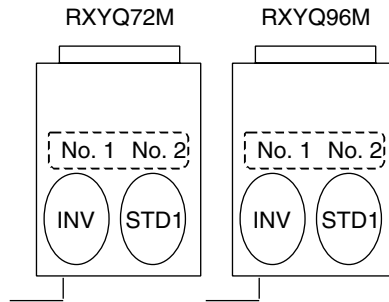

RXYQ72M

| STEP | INV   | STD1 |
|------|-------|------|
| 1    | 52Hz  | OFF  |
| 2    | 57Hz  | OFF  |
| 3    | 62Hz  | OFF  |
| 4    | 68Hz  | OFF  |
| 5    | 74Hz  | OFF  |
| 6    | 81Hz  | OFF  |
| 7    | 88Hz  | OFF  |
| 8    | 96Hz  | OFF  |
| 9    | 104Hz | OFF  |
| 10   | 110Hz | OFF  |
| 11   | 116Hz | OFF  |
| 12   | 124Hz | OFF  |
| 13   | 133Hz | OFF  |
| 14   | 143Hz | OFF  |
| 15   | 158Hz | OFF  |
| 16   | 165Hz | OFF  |
| 17   | 177Hz | OFF  |
| 18   | 189Hz | OFF  |
| 19   | 202Hz | OFF  |
| 20   | 210Hz | OFF  |
| 21   | 52Hz  | ON   |
| 22   | 74Hz  | ON   |
| 23   | 96Hz  | ON   |
| 24   | 116Hz | ON   |
| 25   | 133Hz | ON   |
| 26   | 158Hz | ON   |
| 27   | 177Hz | ON   |
| 28   | 202Hz | ON   |
| 29   | 210Hz | ON   |

RXYQ96M

| STEP | INV   | STD1 |
|------|-------|------|
| 1    | 52Hz  | OFF  |
| 2    | 57Hz  | OFF  |
| 3    | 62Hz  | OFF  |
| 4    | 68Hz  | OFF  |
| 5    | 74Hz  | OFF  |
| 6    | 81Hz  | OFF  |
| 7    | 88Hz  | OFF  |
| 8    | 96Hz  | OFF  |
| 9    | 104Hz | OFF  |
| 10   | 110Hz | OFF  |
| 11   | 116Hz | OFF  |
| 12   | 124Hz | OFF  |
| 13   | 133Hz | OFF  |
| 14   | 143Hz | OFF  |
| 15   | 158Hz | OFF  |
| 16   | 165Hz | OFF  |
| 17   | 177Hz | OFF  |
| 18   | 189Hz | OFF  |
| 19   | 202Hz | OFF  |
| 20   | 210Hz | OFF  |
| 21   | 52Hz  | ON   |
| 22   | 74Hz  | ON   |
| 23   | 96Hz  | ON   |
| 24   | 116Hz | ON   |
| 25   | 133Hz | ON   |
| 26   | 158Hz | ON   |
| 27   | 177Hz | ON   |
| 28   | 202Hz | ON   |
| 29   | 210Hz | ON   |

\*

- Compressors are operated in the order of descending priorities.
- Compressors may operate in a pattern other than those listed in above tables subject to the operating conditions.

■ Compressor Operating Priority

Each compressor operates in the following order of priority.

INV: Inverter compressor

STD1: Standard compressor 1

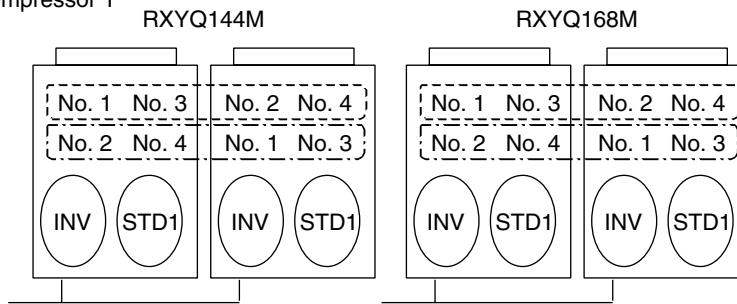

RXYQ144M

| STEP | Master unit<br>INV | Slave unit<br>INV | STD unit<br>No.1 | STD unit<br>No.2 |
|------|--------------------|-------------------|------------------|------------------|
| 1    | 52Hz               | OFF               | OFF              | OFF              |
| 2    | 57Hz               | OFF               | OFF              | OFF              |
| 3    | 62Hz               | OFF               | OFF              | OFF              |
| 4    | 68Hz               | OFF               | OFF              | OFF              |
| 5    | 74Hz               | OFF               | OFF              | OFF              |
| 6    | 81Hz               | OFF               | OFF              | OFF              |
| 7    | 88Hz               | OFF               | OFF              | OFF              |
| 8    | 96Hz               | OFF               | OFF              | OFF              |
| 9    | 104Hz              | OFF               | OFF              | OFF              |
| 10   | 110Hz              | OFF               | OFF              | OFF              |
| 11   | 116Hz              | OFF               | OFF              | OFF              |
| 12   | 124Hz              | OFF               | OFF              | OFF              |
| 13   | 133Hz              | OFF               | OFF              | OFF              |
| 14   | 143Hz              | OFF               | OFF              | OFF              |
| 15   | 158Hz              | OFF               | OFF              | OFF              |
| 16   | 165Hz              | OFF               | OFF              | OFF              |
| 17   | 177Hz              | OFF               | OFF              | OFF              |
| 18   | 189Hz              | OFF               | OFF              | OFF              |
| 19   | 202Hz              | OFF               | OFF              | OFF              |
| 20   | 210Hz              | OFF               | OFF              | OFF              |
| 21   | 52Hz               | 189Hz             | OFF              | OFF              |
| 22   | 74Hz               | 189Hz             | OFF              | OFF              |
| 23   | 96Hz               | 189Hz             | OFF              | OFF              |
| 24   | 116Hz              | 189Hz             | OFF              | OFF              |
| 25   | 133Hz              | 189Hz             | OFF              | OFF              |
| 26   | 158Hz              | 189Hz             | OFF              | OFF              |
| 27   | 177Hz              | 189Hz             | OFF              | OFF              |
| 28   | 202Hz              | 189Hz             | OFF              | OFF              |
| 29   | 210Hz              | 189Hz             | OFF              | OFF              |
| 30   | 52Hz               | 189Hz             | ON               | OFF              |
| 31   | 88Hz               | 189Hz             | ON               | OFF              |
| 32   | 124Hz              | 189Hz             | ON               | OFF              |
| 33   | 158Hz              | 189Hz             | ON               | OFF              |
| 34   | 189Hz              | 189Hz             | ON               | OFF              |
| 35   | 210Hz              | 189Hz             | ON               | OFF              |
| 36   | 52Hz               | 189Hz             | ON               | ON               |
| 37   | 88Hz               | 189Hz             | ON               | ON               |
| 38   | 124Hz              | 189Hz             | ON               | ON               |
| 39   | 158Hz              | 189Hz             | ON               | ON               |
| 40   | 189Hz              | 189Hz             | ON               | ON               |
| 41   | 210Hz              | 189Hz             | ON               | ON               |
| 42   | 210Hz              | 210Hz             | ON               | ON               |

RXYQ168M

| STEP | Master unit<br>INV | Slave unit<br>INV | STD unit<br>No.1 | STD unit<br>No.2 |
|------|--------------------|-------------------|------------------|------------------|
| 1    | 52Hz               | OFF               | OFF              | OFF              |
| 2    | 57Hz               | OFF               | OFF              | OFF              |
| 3    | 62Hz               | OFF               | OFF              | OFF              |
| 4    | 68Hz               | OFF               | OFF              | OFF              |
| 5    | 74Hz               | OFF               | OFF              | OFF              |
| 6    | 81Hz               | OFF               | OFF              | OFF              |
| 7    | 88Hz               | OFF               | OFF              | OFF              |
| 8    | 96Hz               | OFF               | OFF              | OFF              |
| 9    | 104Hz              | OFF               | OFF              | OFF              |
| 10   | 110Hz              | OFF               | OFF              | OFF              |
| 11   | 116Hz              | OFF               | OFF              | OFF              |
| 12   | 124Hz              | OFF               | OFF              | OFF              |
| 13   | 133Hz              | OFF               | OFF              | OFF              |
| 14   | 143Hz              | OFF               | OFF              | OFF              |
| 15   | 158Hz              | OFF               | OFF              | OFF              |
| 16   | 165Hz              | OFF               | OFF              | OFF              |
| 17   | 177Hz              | OFF               | OFF              | OFF              |
| 18   | 189Hz              | OFF               | OFF              | OFF              |
| 19   | 202Hz              | OFF               | OFF              | OFF              |
| 20   | 210Hz              | OFF               | OFF              | OFF              |
| 21   | 52Hz               | 189Hz             | OFF              | OFF              |
| 22   | 74Hz               | 189Hz             | OFF              | OFF              |
| 23   | 96Hz               | 189Hz             | OFF              | OFF              |
| 24   | 116Hz              | 189Hz             | OFF              | OFF              |
| 25   | 133Hz              | 189Hz             | OFF              | OFF              |
| 26   | 158Hz              | 189Hz             | OFF              | OFF              |
| 27   | 177Hz              | 189Hz             | OFF              | OFF              |
| 28   | 202Hz              | 189Hz             | OFF              | OFF              |
| 29   | 210Hz              | 189Hz             | OFF              | OFF              |
| 30   | 52Hz               | 189Hz             | ON               | OFF              |
| 31   | 88Hz               | 189Hz             | ON               | OFF              |
| 32   | 124Hz              | 189Hz             | ON               | OFF              |
| 33   | 158Hz              | 189Hz             | ON               | OFF              |
| 34   | 189Hz              | 189Hz             | ON               | OFF              |
| 35   | 210Hz              | 189Hz             | ON               | OFF              |
| 36   | 52Hz               | 189Hz             | ON               | ON               |
| 37   | 88Hz               | 189Hz             | ON               | ON               |
| 38   | 124Hz              | 189Hz             | ON               | ON               |
| 39   | 158Hz              | 189Hz             | ON               | ON               |
| 40   | 189Hz              | 189Hz             | ON               | ON               |
| 41   | 210Hz              | 189Hz             | ON               | ON               |
| 42   | 210Hz              | 210Hz             | ON               | ON               |

\*

- Compressors are operated in the order of descending priorities.
- Compressors may operate in a pattern other than those listed in above tables subject to the operating conditions.

### ■ Compressor Operating Priority

Each compressor operates in the following order of priority.

INV: Inverter compressor

STD1: Standard compressor 1

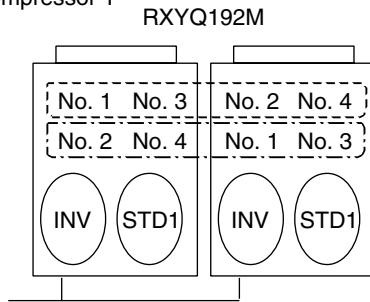

### RXYQ192M

| STEP | Master unit<br>INV | Slave unit<br>INV | STD unit<br>No.1 | STD unit<br>No.2 |
|------|--------------------|-------------------|------------------|------------------|
| 1    | 52Hz               | OFF               | OFF              | OFF              |
| 2    | 57Hz               | OFF               | OFF              | OFF              |
| 3    | 62Hz               | OFF               | OFF              | OFF              |
| 4    | 68Hz               | OFF               | OFF              | OFF              |
| 5    | 74Hz               | OFF               | OFF              | OFF              |
| 6    | 81Hz               | OFF               | OFF              | OFF              |
| 7    | 88Hz               | OFF               | OFF              | OFF              |
| 8    | 96Hz               | OFF               | OFF              | OFF              |
| 9    | 104Hz              | OFF               | OFF              | OFF              |
| 10   | 110Hz              | OFF               | OFF              | OFF              |
| 11   | 116Hz              | OFF               | OFF              | OFF              |
| 12   | 124Hz              | OFF               | OFF              | OFF              |
| 13   | 133Hz              | OFF               | OFF              | OFF              |
| 14   | 143Hz              | OFF               | OFF              | OFF              |
| 15   | 158Hz              | OFF               | OFF              | OFF              |
| 16   | 165Hz              | OFF               | OFF              | OFF              |
| 17   | 177Hz              | OFF               | OFF              | OFF              |
| 18   | 189Hz              | OFF               | OFF              | OFF              |
| 19   | 202Hz              | OFF               | OFF              | OFF              |
| 20   | 210Hz              | OFF               | OFF              | OFF              |
| 21   | 52Hz               | 189Hz             | OFF              | OFF              |
| 22   | 74Hz               | 189Hz             | OFF              | OFF              |
| 23   | 96Hz               | 189Hz             | OFF              | OFF              |
| 24   | 116Hz              | 189Hz             | OFF              | OFF              |
| 25   | 133Hz              | 189Hz             | OFF              | OFF              |
| 26   | 158Hz              | 189Hz             | OFF              | OFF              |
| 27   | 177Hz              | 189Hz             | OFF              | OFF              |
| 28   | 202Hz              | 189Hz             | OFF              | OFF              |
| 29   | 210Hz              | 189Hz             | OFF              | OFF              |
| 30   | 52Hz               | 189Hz             | ON               | OFF              |
| 31   | 88Hz               | 189Hz             | ON               | OFF              |
| 32   | 124Hz              | 189Hz             | ON               | OFF              |
| 33   | 158Hz              | 189Hz             | ON               | OFF              |
| 34   | 189Hz              | 189Hz             | ON               | OFF              |
| 35   | 210Hz              | 189Hz             | ON               | OFF              |
| 36   | 52Hz               | 189Hz             | ON               | ON               |
| 37   | 88Hz               | 189Hz             | ON               | ON               |
| 38   | 124Hz              | 189Hz             | ON               | ON               |
| 39   | 158Hz              | 189Hz             | ON               | ON               |
| 40   | 189Hz              | 189Hz             | ON               | ON               |
| 41   | 210Hz              | 189Hz             | ON               | ON               |
| 42   | 210Hz              | 210Hz             | ON               | ON               |

\*

- Compressors are operated in the order of descending priorities.
- Compressors may operate in a pattern other than those listed in above tables subject to the operating conditions.



## 2.3 Electronic Expansion Valve PI Control

---

### Main Motorized Valve EV1 Control

Carries out the motorized valve (Y1E) PI control to maintain the evaporator outlet superheated degree (SH) at constant during heating operation to make maximum use of the outdoor unit heat exchanger (evaporator).

$$SH = T_s - T_e$$

SH : Evaporator outlet superheated degree (°F)

T<sub>s</sub> : Suction pipe temperature detected by thermistor R2T (°F)

T<sub>e</sub> : Low pressure equivalent saturation temperature (°F)

The optimum initial value of the evaporator outlet superheated degree is 9°F, but varies depending on the discharge pipe superheated degree of inverter compressor.

---

### Subcooling Motorized Valve EV2 Control

Makes PI control of the motorized valve (Y2E) to keep the superheated degree of the outlet gas pipe on the evaporator side for the full use of the subcooling heat exchanger.

$$SH = T_{sh} - T_e$$

SH : Outlet superheated degree of evaporator (°F)

T<sub>sh</sub> : Suction pipe temperature detected with the thermistor R5T (°F)

T<sub>e</sub> : Low pressure equivalent saturation temperature (°F)

## 2.4 Cooling Operation Fan Control

In cooling operation with low outdoor air temperature, this control is used to provide the adequate amount of circulation air with liquid pressure secured by high pressure control using outdoor unit fan.

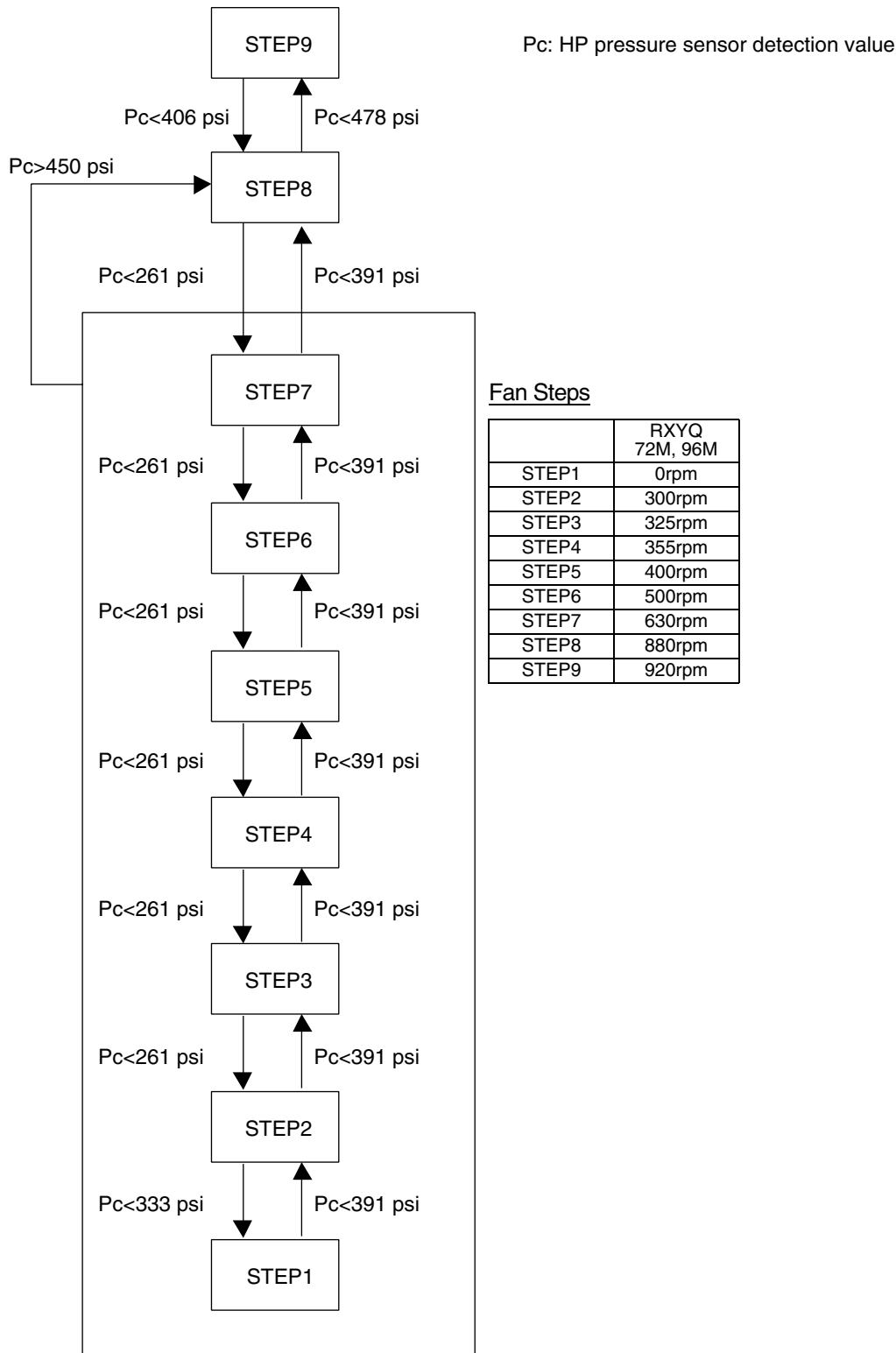

Fan Steps

|       | RXYQ<br>72M, 96M |
|-------|------------------|
| STEP1 | 0rpm             |
| STEP2 | 300rpm           |
| STEP3 | 325rpm           |
| STEP4 | 355rpm           |
| STEP5 | 400rpm           |
| STEP6 | 500rpm           |
| STEP7 | 630rpm           |
| STEP8 | 880rpm           |
| STEP9 | 920rpm           |

## 3. Special Control

### 3.1 Startup Control

#### 3.1.1 Startup Control in Cooling Operation

| Actuator   | Operation   | Remarks  |
|--|---|--|
| Compressor                                       | Differential pressure control   | Compressor operating frequency increases by 1 step / 20 sec until $P_c - P_e > 58$ psi   |
| Outdoor unit fan                                 | High pressure control   | Initial compressor operating frequency is set to STEP 1.<br>1-step increase with $P_c > 319$ psi<br>1-step decrease with $P_c < 261$ psi |
| Four way valve                                   | OFF   | —  |
| Main motorized valve (EV1)                       | 0 pls   | —  |
| Subcooling motorized valve (EV2)                 | 0 pls   | —  |
| Hot gas bypass valve (SVP)                       | ON  | —  |
| Oil equalization valve (SVO)                     | ON  | —  |
| Receiver gas charging valve (SVL)                | OFF   | —  |
| Receiver gas discharging valve (SVG)             | OFF   | —  |
| Non-operating unit gas discharging valve (SVSG)  | OFF   | —  |
| Non-operating unit liquid pipe stop valve (SVSL) | ON  | —  |
| Ending conditions                                | or <ul style="list-style-type: none"> <li>• 200 sec.</li> <li>• <math>P_c - P_e &gt; 58</math> psi</li> </ul> |  |

#### 3.1.2 Startup Control in Heating Operation

| Actuator   | Operation   | Remarks  |
|--|---|--|
| Compressor                                       | Differential pressure control   | Compressor operating frequency increases by 1 step / 20 sec until $P_c - P_e > 58$ psi |
| Outdoor unit fan                                 | STEP9   | —  |
| Four way valve                                   | ON  | —  |
| Main motorized valve (EV1)                       | 200 pls   | —  |
| Subcooling motorized valve (EV2)                 | 0 pls   | —  |
| Hot gas bypass valve (SVP)                       | ON  | —  |
| Oil equalization valve (SVO)                     | ON  | —  |
| Receiver gas charging valve (SVL)                | OFF   | —  |
| Receiver gas discharging valve (SVG)             | OFF   | —  |
| Non-operating unit gas discharging valve (SVSG)  | OFF   | —  |
| Non-operating unit liquid pipe stop valve (SVSL) | ON  | —  |
| Ending conditions                                | or <ul style="list-style-type: none"> <li>• 200 sec.</li> <li>• <math>P_c - P_e &gt; 58</math> psi</li> </ul> |  |

## 3.2 Oil Return Operation

### 3.2.1 Oil Return Operation in Cooling Operation

| Outdoor unit actuator                            | Oil return preparation operation | Oil return operation   | Post-oil-return operation |
|--|----------------------------------|--|---------------------------|
| Compressor                                       | Upper limit control              | 124 Hz + ON  | 52 Hz + OFF               |
| Outdoor unit fan                                 | Fan control                      | Fan control  | Fan control               |
| Four way valve                                   | OFF                              | OFF  | OFF                       |
| Main motorized valve (EV1)                       | 0 pls                            | 0 pls  | 0 pls                     |
| Subcooling motorized valve (EV2)                 | SH control                       | 0 pls  | 0 pls                     |
| Hot gas bypass valve (SVP)                       | OFF                              | ON   | ON                        |
| Oil equalization valve (SVO)                     | ON                               | ON   | ON                        |
| Receiver gas charging valve (SVL)                | OFF                              | OFF  | OFF                       |
| Receiver gas discharging valve (SVG)             | OFF                              | OFF  | OFF                       |
| Non-operating unit gas discharging valve (SVSG)  | OFF                              | OFF  | OFF                       |
| Non-operating unit liquid pipe stop valve (SVSL) | ON                               | ON   | ON                        |
| Ending conditions                                | 2 min.                           | or <ul style="list-style-type: none"> <li>• 6 min.</li> <li>• <math>T_s - T_e &lt; 9</math></li> </ul> | 10 sec.                   |

| Indoor unit actuator       |                     | Cooling oil return operation |
|----------------------------|---------------------|------------------------------|
| Fan                        | Thermostat ON unit  | Set Air Volume               |
|                            | Stopping unit       | OFF                          |
|                            | Thermostat OFF unit | OFF                          |
| Electronic expansion valve | Thermostat ON unit  | Normal opening               |
|                            | Stopping unit       | 200 pls                      |
|                            | Thermostat OFF unit | 200 pls                      |

### 3.2.2 Oil Return Operation in Heating Operation

| Outdoor Unit Actuator                            | Oil return preparation operation | Oil return operation  | Post-oil-return operation  |
|--|----------------------------------|---|--|
| Compressor                                       | Upper limit control              | 124 Hz + ON   | 1-step increase from (74 Hz + OFF) to (Pc - Pe>58 psi) time                                    |
| Outdoor unit fan                                 | STEP8 or STEP9                   | OFF   | STEP9  |
| Four way valve                                   | ON                               | OFF   | ON   |
| Main motorized valve (EV1)                       | SH control                       | 0 pls   | 180 pls  |
| Subcooling motorized valve (EV2)                 | 0 pls                            | 0 pls   | 0 pls  |
| Hot gas bypass valve (SVP)                       | OFF                              | ON  | ON   |
| Oil equalization valve (SVO)                     | ON                               | ON  | ON   |
| Receiver gas charging valve (SVL)                | OFF                              | OFF   | OFF  |
| Receiver gas discharging valve (SVG)             | OFF                              | OFF   | OFF  |
| Non-operating unit gas discharging valve (SVSG)  | OFF                              | OFF   | OFF  |
| Non-operating unit liquid pipe stop valve (SVSL) | ON                               | ON  | ON   |
| Ending conditions                                | 2 min.                           | or [ <ul style="list-style-type: none"> <li>• 6 min.</li> <li>• Ts - Te&lt;9</li> </ul> | or [ <ul style="list-style-type: none"> <li>• 160 sec.</li> <li>• Pc - Pe&gt;58 psi</li> </ul> |

| Indoor unit actuator       |                     | Heating oil return operation |
|----------------------------|---------------------|------------------------------|
| Fan                        | Thermostat ON unit  | OFF                          |
|                            | Stopping unit       | OFF                          |
|                            | Thermostat OFF unit | OFF                          |
| Electronic expansion valve | Thermostat ON unit  | 512 pls                      |
|                            | Stopping unit       | 512 pls                      |
|                            | Thermostat OFF unit | 512 pls                      |

<In condition of oil return operation>  
 Compressor cumulative operation time > 8 hours  
 (However, 2 hours after turning power on first time.)

### 3.3 Defrosting Operation

| Outdoor unit actuator                            | Defrost preparation operation | Defrost operation   | Post Defrost operation   |
|--|-------------------------------|---|--|
| Compressor                                       | Upper limit control           | 143 Hz + ON   | 1-step increase from (74 Hz + OFF) to (Pc - Pe>58 psi)   |
| Outdoor unit fan                                 | STEP8 or STEP9                | OFF   | STEP9  |
| Four way valve                                   | ON                            | OFF   | ON   |
| Main motorized valve (EV1)                       | SH control                    | 0 pls   | 200 pls  |
| Subcooling motorized valve (EV2)                 | 0 pls                         | 0 pls   | 0 pls  |
| Hot gas bypass valve (SVP)                       | OFF                           | ON  | ON   |
| Oil equalization valve (SVO)                     | ON                            | ON  | ON   |
| Receiver gas charging valve (SVL)                | OFF                           | OFF   | OFF  |
| Receiver gas discharging valve (SVG)             | OFF                           | OFF   | OFF  |
| Non-operating unit gas discharging valve (SVSG)  | OFF                           | OFF   | OFF  |
| Non-operating unit liquid pipe stop valve (SVSL) | ON                            | ON  | ON   |
| Ending conditions                                | 2 min.                        | or [ <ul style="list-style-type: none"> <li>• 12 min.</li> <li>• Ts &gt;52°F</li> </ul> | or [ <ul style="list-style-type: none"> <li>• 160 sec.</li> <li>• Pc - Pe&gt;58 psi</li> </ul> |

| Indoor unit actuator       |                     | During defrost |
|----------------------------|---------------------|----------------|
| Fan                        | Thermostat ON unit  | OFF            |
|                            | Stopping unit       | OFF            |
|                            | Thermostat OFF unit | OFF            |
| Electronic expansion valve | Thermostat ON unit  | 512 pls        |
|                            | Stopping unit       | 512 pls        |
|                            | Thermostat OFF unit | 512 pls        |

<Defrost starting condition>

Defrost operation is started when the outdoor heat exchanger temperature becomes lower than deicer temperature. Defrost operation is conducted once in max. 2 hours.

### 3.4 Pump-down Residual Operation

#### 3.4.1 Pump-down Residual Operation in Cooling Operation

| Actuator   | Operation  |
|--|--|
| Compressor                                       | 210 Hz + OFF   |
| Outdoor unit fan                                 | Fan control  |
| Four way valve                                   | OFF  |
| Main motorized valve (EV1)                       | 0 pls  |
| Subcooling motorized valve (EV2)                 | 0 pls  |
| Hot gas bypass valve (SVP)                       | ON   |
| Oil equalization valve (SVO)                     | ON   |
| Receiver gas charging valve (SVL)                | OFF  |
| Receiver gas discharging valve (SVG)             | ON   |
| Non-operating unit gas discharging valve (SVSG)  | OFF  |
| Non-operating unit liquid pipe stop valve (SVSL) | ON   |
| Ending conditions                                | or <ul style="list-style-type: none"> <li>• 5 min.</li> <li>• Pe&lt;72.5 psi</li> <li>• Td&gt;230°F</li> </ul> |

#### 3.4.2 Pump-down Residual Operation in Heating Operation

| Actuator   | Operation   |
|--|---|
| Compressor                                       | 124 Hz + OFF  |
| Outdoor unit fan                                 | STEP8   |
| Four way valve                                   | ON  |
| Main motorized valve (EV1)                       | 0 pls   |
| Subcooling motorized valve (EV2)                 | 0 pls   |
| Hot gas bypass valve (SVP)                       | ON  |
| Oil equalization valve (SVO)                     | ON  |
| Receiver gas charging valve (SVL)                | OFF   |
| Receiver gas discharging valve (SVG)             | ON  |
| Non-operating unit gas discharging valve (SVSG)  | OFF   |
| Non-operating unit liquid pipe stop valve (SVSL) | ON  |
| Ending conditions                                | or <ul style="list-style-type: none"> <li>• 30 sec.</li> <li>• Pe&lt;36 psi</li> <li>• Td&gt;230°F</li> </ul> |

### 3.5 Restart Standby

| Actuator   | Operation                      |
|--|--------------------------------|
| Compressor                                       | OFF                            |
| Outdoor unit fan                                 | Ta>86°F: STEP5<br>Ta≤86°F: OFF |
| Four way valve                                   | Holds                          |
| Main motorized valve (EV1)                       | 0 pls                          |
| Subcooling motorized valve (EV2)                 | 0 pls                          |
| Hot gas bypass valve (SVP)                       | OFF                            |
| Oil equalization valve (SVO)                     | ON                             |
| Receiver gas charging valve (SVL)                | OFF                            |
| Receiver gas discharging valve (SVG)             | OFF                            |
| Non-operating unit gas discharging valve (SVSG)  | OFF                            |
| Non-operating unit liquid pipe stop valve (SVSL) | ON                             |
| Ending conditions                                | 5 min.                         |



## 3.6 Stopping Operation

### 3.6.1 When System is in Stop Mode

| Actuator   | Operation                            |
|--|--------------------------------------|
| Compressor                                       | OFF                                  |
| Outdoor unit fan                                 | OFF                                  |
| Four way valve                                   | Holds                                |
| Main motorized valve (EV1)                       | 0 pls                                |
| Subcooling motorized valve (EV2)                 | 0 pls                                |
| Hot gas bypass valve (SVP)                       | OFF                                  |
| Oil equalization valve (SVO)                     | OFF                                  |
| Receiver gas charging valve (SVL)                | OFF                                  |
| Receiver gas discharging valve (SVG)             | OFF                                  |
| Non-operating unit gas discharging valve (SVSG)  | OFF                                  |
| Non-operating unit liquid pipe stop valve (SVSL) | ON                                   |
| Ending conditions                                | Indoor unit thermostat is turned ON. |

### 3.6.2 Stopping Operation of Slave Units During Master Unit is in Operation with Multi-Outdoor-Unit System

In cooling operation: The system operates in Mode A or Mode B listed in the table below.

| Actuator   | Mode-A operation   | Mode-B operation  |
|--|--|---|
| Compressor                                       | OFF  | OFF   |
| Outdoor unit fan                                 | STEP4  | OFF   |
| Four way valve                                   | OFF  | Holds   |
| Main motorized valve (EV1)                       | 150 pls to 300 pls                                       | 0 pls   |
| Subcooling motorized valve (EV2)                 | 0 pls  | 0 pls   |
| Hot gas bypass valve (SVP)                       | ON   | ON  |
| Oil equalization valve (SVO)                     | OFF  | OFF   |
| Receiver gas discharging valve (SVG)             | OFF  | OFF   |
| Non-operating unit liquid pipe stop valve (SVSL) | OFF  | ON  |
| Mode transition conditions                       | To Mode B when $T_c - T_l > 0.27 \times (T_c - T_a) + 6$ | To Mode A when gas shortage signal is sent from indoor unit |
| Ending conditions                                | Slave units are required to operate.                     |   |

In heating operation: The system operates in Mode A or Mode B listed in the table below.

| Actuator   | Mode-A operation  | Mode-B operation  |
|--|---|---|
| Compressor                                       | OFF   | OFF   |
| Outdoor unit fan                                 | STEP2   | STEP2   |
| Four way valve                                   | ON  | ON  |
| Main motorized valve (EV1)                       | 0 pls   | 0 pls   |
| Subcooling motorized valve (EV2)                 | 0 pls   | 0 pls   |
| Hot gas bypass valve (SVP)                       | OFF   | OFF   |
| Oil equalization valve (SVO)                     | OFF   | OFF   |
| Receiver gas discharging valve (SVG)             | OFF   | OFF   |
| Non-operating unit liquid pipe stop valve (SVSL) | OFF   | ON  |
| Mode transition conditions                       | To Mode B when $T_c - \text{mean temperature of indoor unit liquid pipes} > 10^\circ\text{C}$ | To Mode A when motorized valve of operating outdoor unit fully opens. |
| Ending conditions                                | Slave units are required to operate.  |   |

\* Mode A or B operation

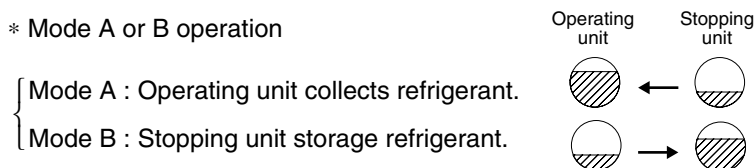

The changeover operation for mode A and B is performed for the reason that the required refrigerant amount varies depending on the indoor unit operation capacity.

### 3.7 Pressure Equalization prior to Startup

| Actuator   | Operation                     |
|--|-------------------------------|
| Compressor                                       | OFF                           |
| Outdoor unit fan                                 | Cooling:OFF<br>Heating:STEP 4 |
| Four way valve                                   | Holds                         |
| Main motorized valve (EV1)                       | 0 pls                         |
| Subcooling motorized valve (EV2)                 | 0 pls                         |
| Hot gas bypass valve (SVP)                       | OFF                           |
| Oil equalization valve (SVO)                     | OFF                           |
| Receiver gas charging valve (SVL)                | OFF                           |
| Receiver gas discharging valve (SVG)             | OFF                           |
| Non-operating unit gas discharging valve (SVSG)  | OFF                           |
| Non-operating unit liquid pipe stop valve (SVSL) | OFF                           |
| Ending conditions                                | 10 sec.                       |

# 4. Protection Control

## 4.1 High Pressure Protection Control

This high pressure protection control is used to prevent the activation of protection devices due to abnormal increase of high pressure and to protect compressors against the transient increase of high pressure.

[In cooling operation]

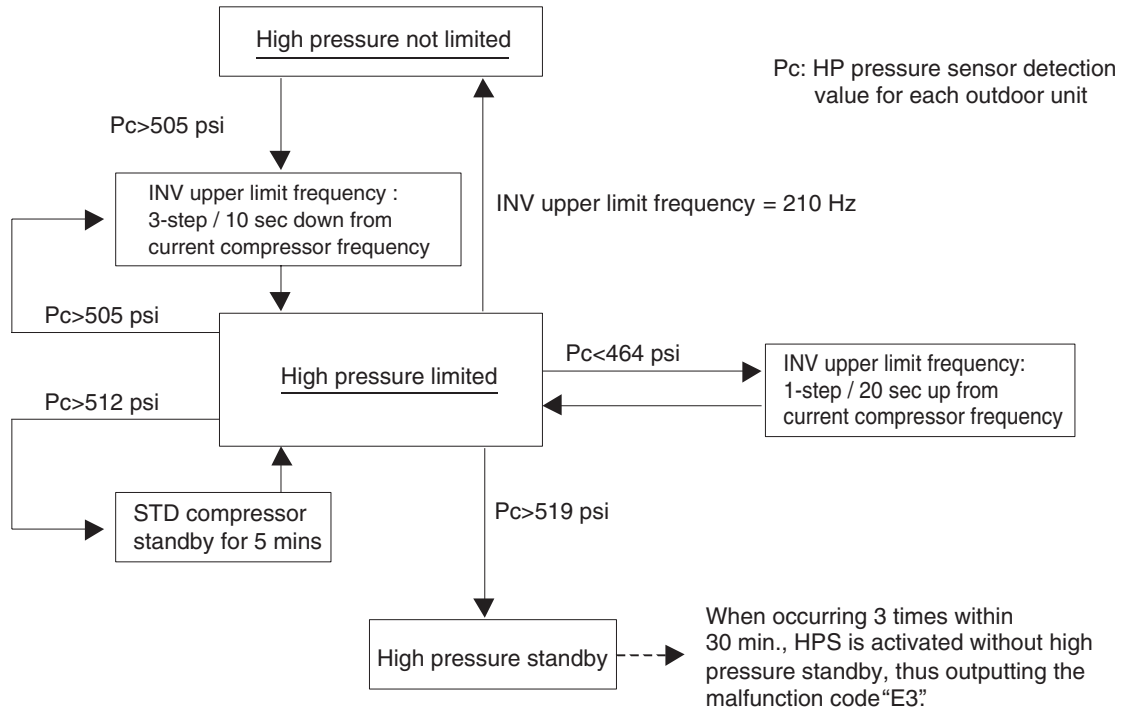

[In heating operation]

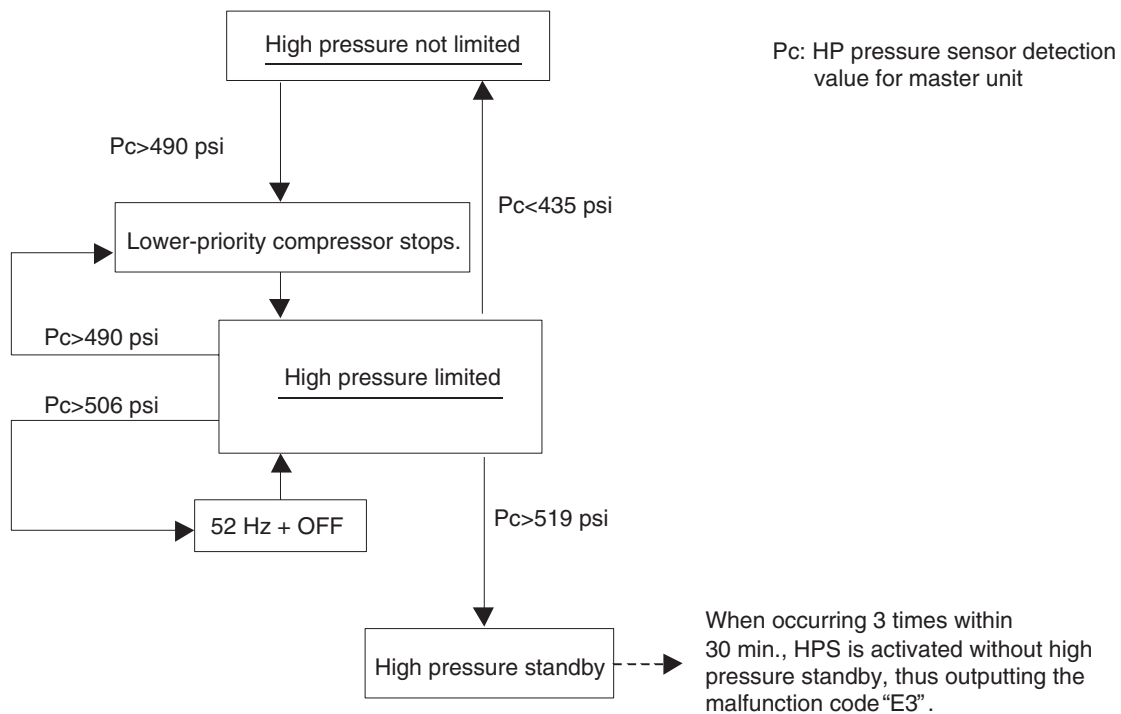

## 4.2 Low Pressure Protection Control

This low pressure protection control is used to protect compressors against the transient decrease of low pressure.

[In cooling operation]

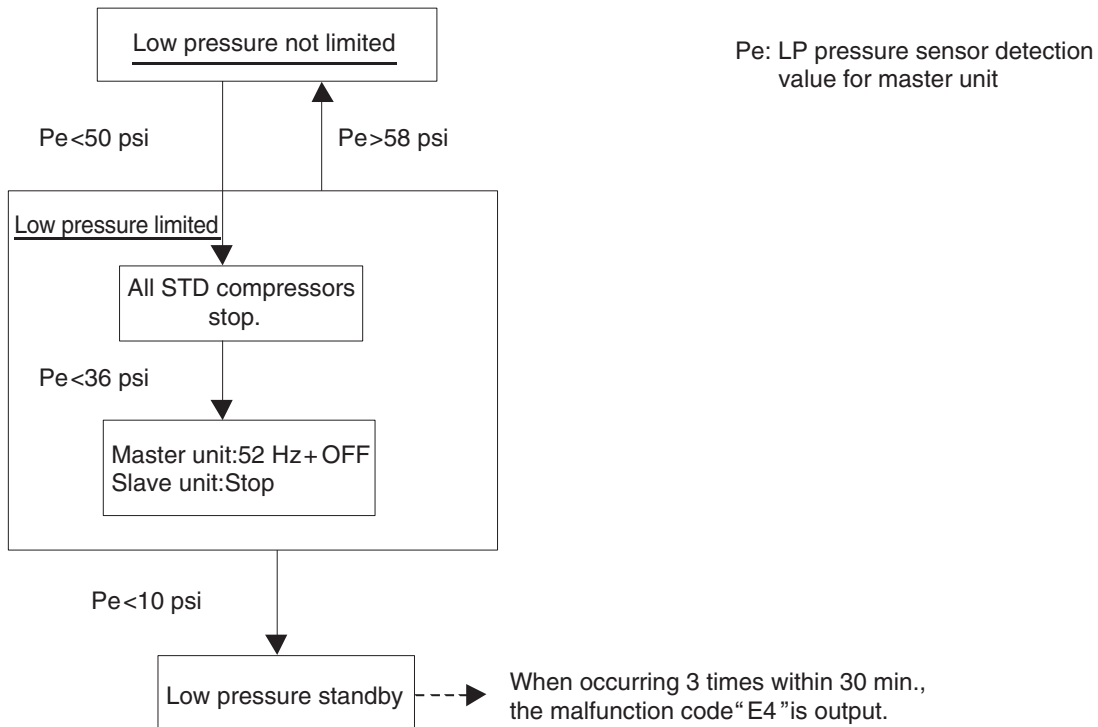

[In heating operation]

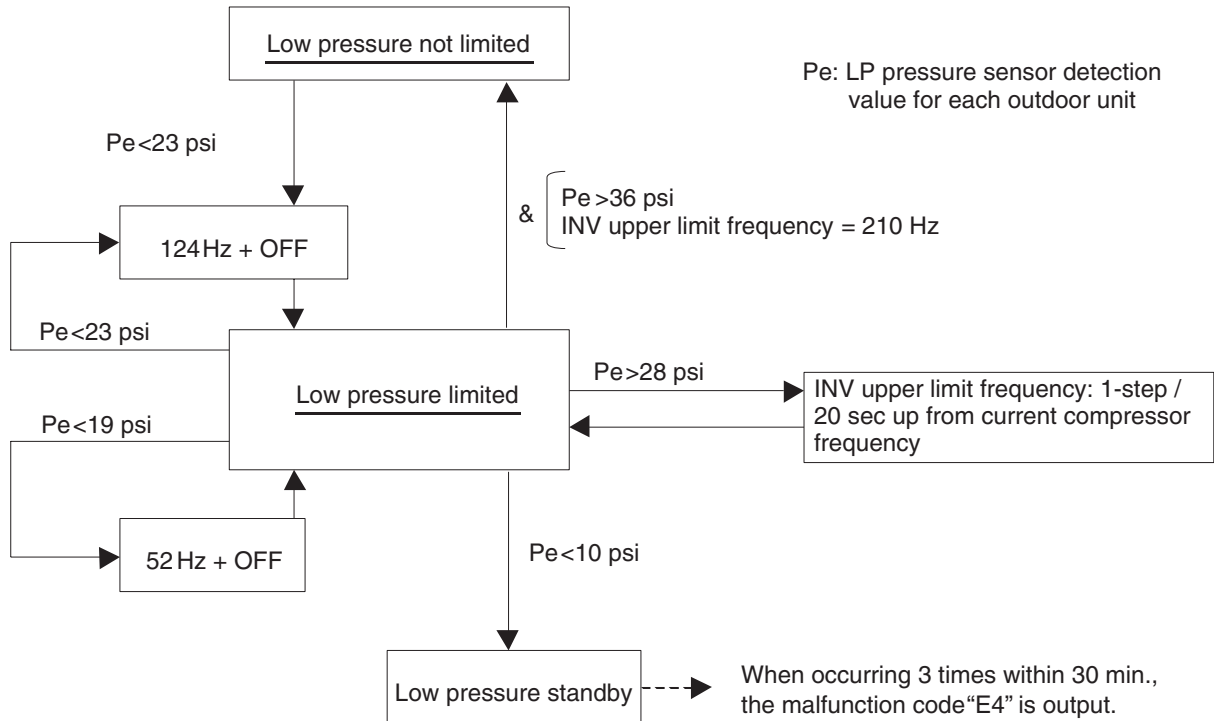

### 4.3 Discharge Pipe Protection Control

This discharge pipe protection control is used to protect the compressor internal temperature against a malfunction or transient increase of discharge pipe temperature.

- ★ Each compressor performs the discharge pipe temperature protection control individually in the following sequence.

[INV compressor]

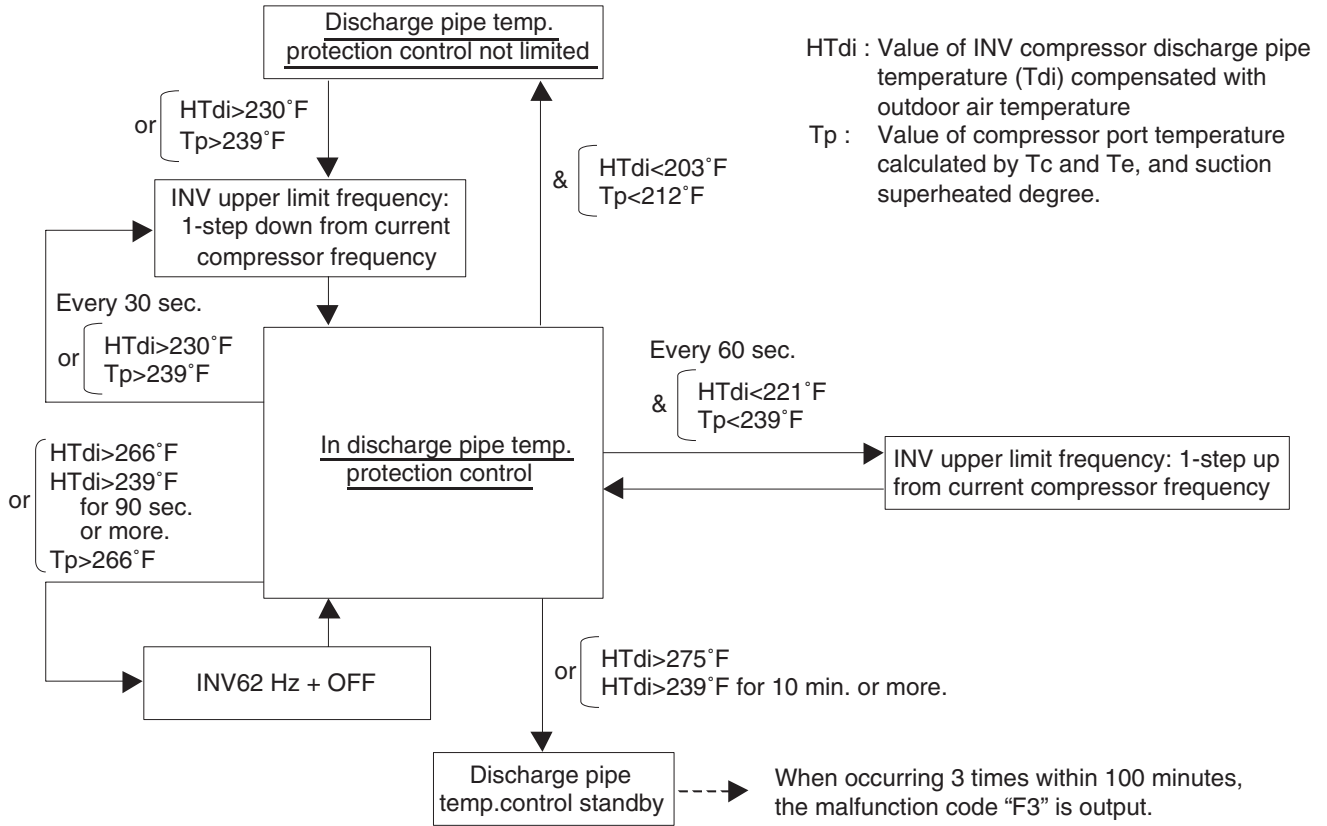

[STD compressor]

HTds : Value of STD compressor discharge pipe temperature (Tds) compensated with outdoor air temperature  
 Tp : Value of compressor port temperature calculated by Tc and Te, and suction superheated degree.

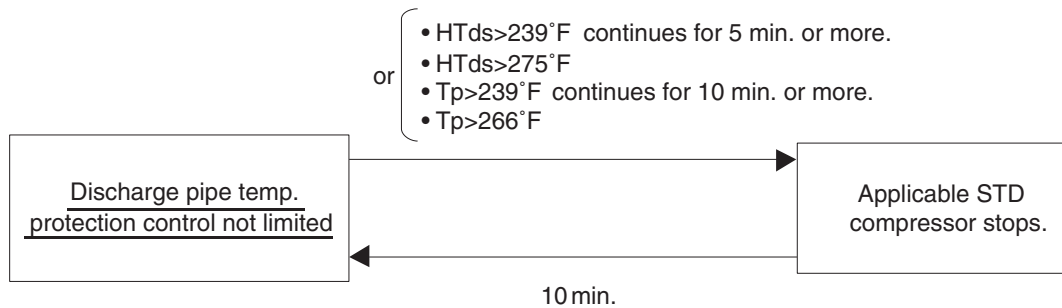

## 4.4 Inverter Protection Control

Inverter current protection control and inverter fin temperature control are performed to prevent tripping due to a malfunction, or transient inverter overcurrent, and fin temperature increase.

[Inverter overcurrent protection control]

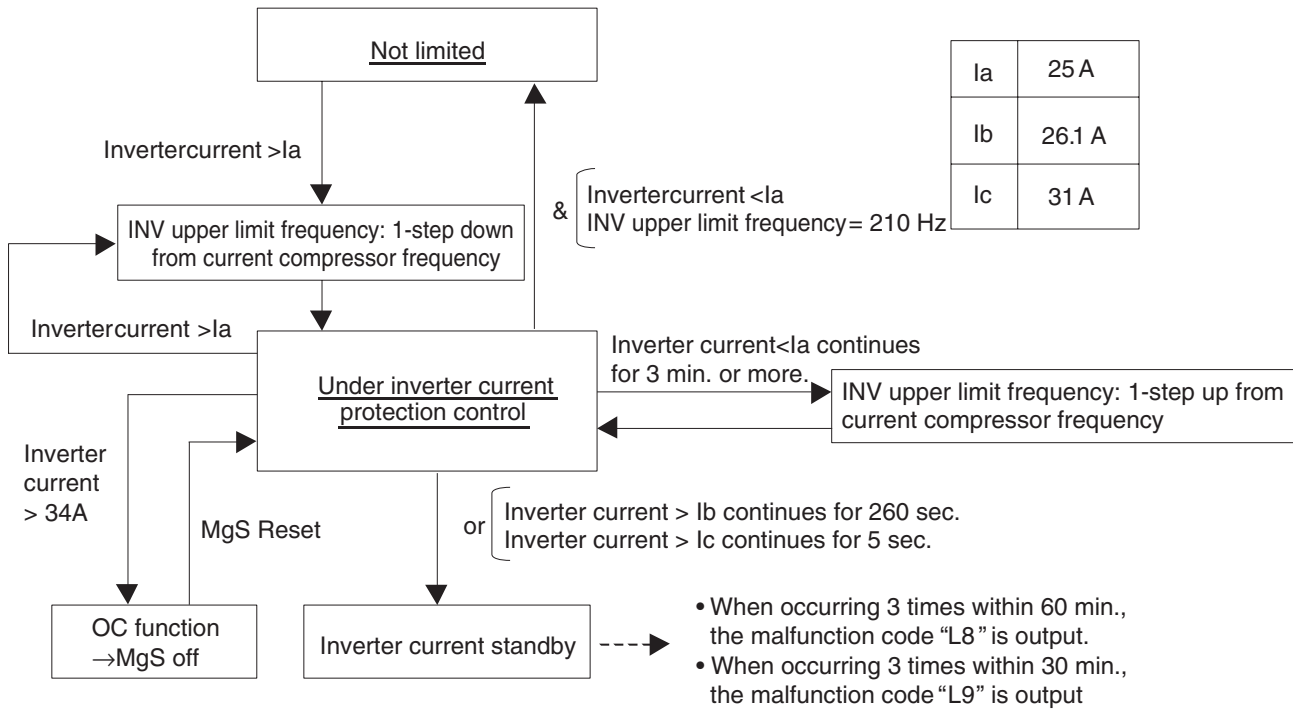

[Inverter fin temperature control]

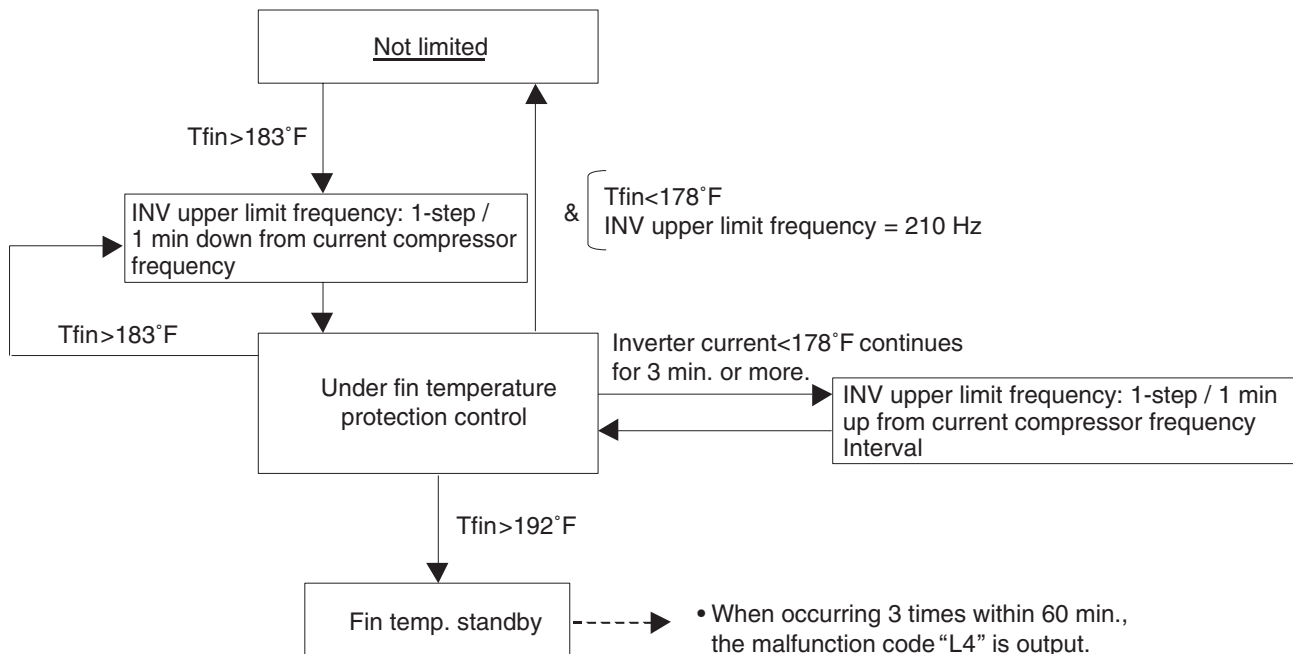

## 4.5 STD Compressor Overload Protection

This control is used to prevent abnormal heating due to overcurrent to the compressor resulting from failures of STD compressor such as locking.

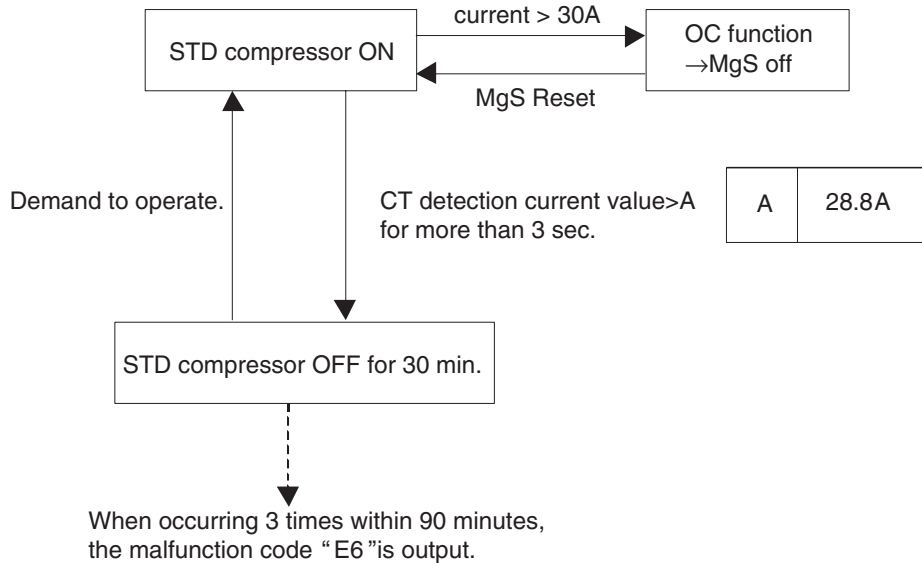



## 5. Other Control

### 5.1 Outdoor Unit Rotation

In the case of multi-outdoor-unit system, this outdoor unit rotation is used to prevent the compressor from burning out due to unbalanced oil level between outdoor units.

#### [Details of outdoor unit rotation]

In the case of multi-outdoor-unit system, each outdoor unit is given an operating priority for the control.

Outdoor unit rotation makes it possible to change the operating priority of outdoor units.

Thus, the system becomes free of compressors that stop over an extended period of time at the time of partial loading, preventing unbalanced oil level.

#### [Timing of outdoor unit rotation]

or {  
 After oil return operation  
 After defrosting operation  
 At the beginning of the starting control

Example) The following diagram shows outdoor unit rotation in combination of 3 outdoor units.

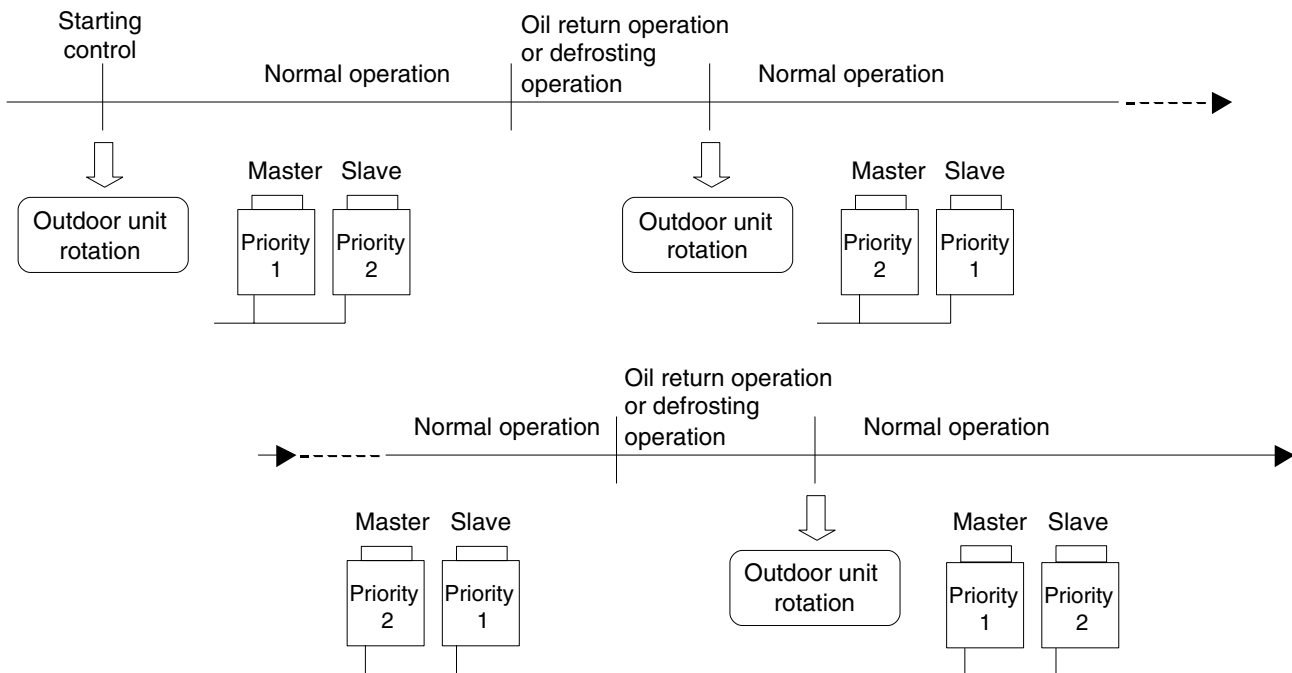

\* “Master unit” and “slave unit” in this section are the names for installation.

They are determined in installation work, and not changed thereafter. (These names are different from “master unit” and “slave unit” for control.)

The outdoor unit connected the control wires (F1 and F2) for the indoor unit should be designated as master unit

Consequently, The LED display on the main PCB for “master unit”, “slave unit” do not change. (Refer to the page 56.)

## 5.2 Emergency Operation

If the compressor cannot operate, this control inhibits any applicable compressor or outdoor unit from operating to perform emergency operation only with the operative compressor or outdoor unit.



### Caution

"For making a compressor unable to operate due to malfunction, etc., be sure to conduct the work with emergency operation setting.

Never execute work such as disconnection of the power cable from magnet contactor. (Otherwise, other normal compressors may malfunction.)

\* Because the units will be operated in the combination with which oil pressure equalization between compressors cannot be performed.

### 5.2.1 Restrictions for Emergency Operation

- In the case of system with 1 outdoor unit installed, only when thermostats of indoor units having a capacity of 50% or more of the outdoor unit capacity turn ON, the emergency operation is functional. (If the total capacity of indoor units with thermostat ON is small, the outdoor unit cannot operate.)
- If the emergency operation is set while the outdoor unit is in operation, the outdoor unit stops once after pump-down residual operation (a maximum of 5 minutes elapsed).

### 5.2.2 In the Case of 1-Outdoor-Unit System

- Emergency operation with settings in service mode
- \* "Inhibition of operation" is set with each compressor.
- To inhibit INV compressor from operating → Set setting mode 2 from No. 0 to No. 2.

(Procedure)

- (1) Press and hold the MODE button (BS1) for 5 sec. or more.
- (2) Press the RETURN button (BS3) once.
- (3) Press the SET button (BS2) once.
- (4) Press the RETURN button (BS3) twice.
- (5) Press the MODE button (BS1) once.

LED display (○:ON ●:OFF ◐:Blink)  
H1P — — — H7P

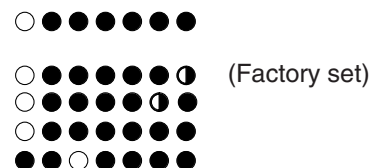

- To inhibit STD1 compressors from operating → Set setting mode 2 from No. 19 to No. 2.

(Procedure)

- (1) Press and hold the MODE button (BS1) for 5 sec. or more.
- (2) Press the SET button (BS2) 19 times.
- (3) Press the RETURN button (BS3) once.
- (4) Press the SET button (BS2) once.
- (5) Press the RETURN button (BS3) twice.
- (6) Press the MODE button (BS1) once.

LED display (○:ON ●:OFF ◐:Blink)  
H1P — — — H7P

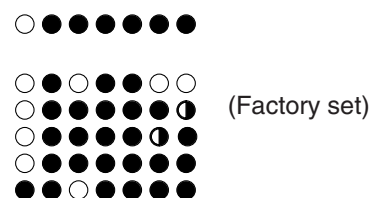

### 5.2.3 In The Case of Multi-Outdoor-Unit System (RXYQ144, 168, 192MTJU)

**Automatic backup operation**

With multi-outdoor-unit system, if a certain outdoor unit system malfunctions (i.e., the system stops and indoor unit remote controller displays the malfunction), by resetting the system with the indoor unit remote controller, the applicable outdoor unit is inhibited from operating for 8 hours, thus making it possible to perform emergency operation automatically.

However, in the event any of the following malfunctions occurs, automatic backup operation can be performed.

Malfunctions under which automatic backup operation can be performed:

- E3, E4, E5, E7
- F3
- H7, H9
- J2, J3, J5, J6, J7, J9, JA, JC
- L3, L4, L5, L8, L9, LC
- U2, UJ

**Emergency operation with settings in service mode**

\* "Inhibition of operation" is set with each outdoor unit.

Make the following settings with the master unit. (Setting with the slave unit becomes disabled.)

\* Discriminate the operating status of the master unit/slave units through the following LED display.

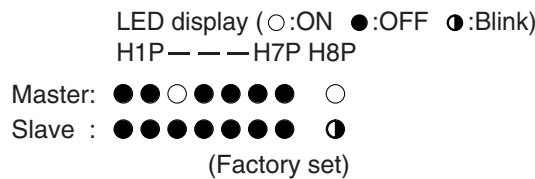

- To inhibit the master unit from operating → Set setting mode 2 from No. 38 to No. 2.

(Procedure)

- (1) Press and hold the MODE button (BS1) for 5 sec. or more.
- (2) Press the SET button (BS2) 38 times.
- (3) Press the RETURN button (BS3) once.
- (4) Press the SET button (BS2) once.
- (5) Press the RETURN button (BS3) twice.
- (6) Press the MODE button (BS1) once.

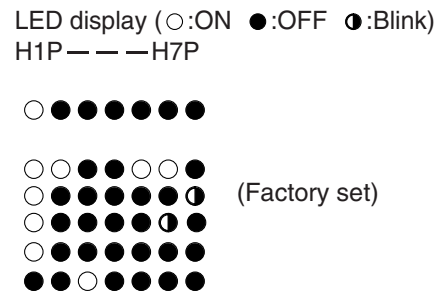

- To inhibit the slave unit from operating → Set setting mode 2 from No. 39 to No. 2.

(Procedure)

- (1) Press and hold the MODE button (BS1) for 5 sec. or more.
- (2) Press the SET button (BS2) 39 times.
- (3) Press the RETURN button (BS3) once.
- (4) Press the SET button (BS2) once.
- (5) Press the RETURN button (BS3) twice.
- (6) Press the MODE button (BS1) once.

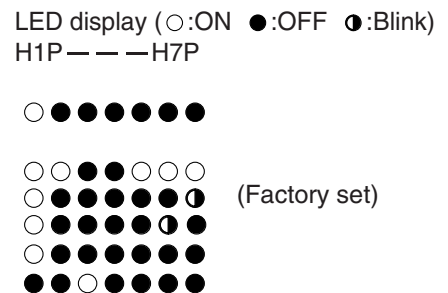

## 5.3 Demand Operation

In order to save the power consumption, the capacity of outdoor unit is saved with control forcibly by using "Demand 1 Setting" or "Demand 2 Setting".

To operate the unit with this mode, additional setting of "Continuous Demand Setting" or external input by external control adapter is required.

### [Demand 1 setting]

| Setting                              | Standard for upper limit of power consumption |
|--------------------------------------|---|
| Demand 1 setting 1                   | Approx. 80%                                   |
| Demand 1 setting 2 (factory setting) | Approx. 70%                                   |
| Demand 1 setting 3                   | Approx. 60%                                   |

### [Demand 2 setting]

| Setting                              | Standard for upper limit of power consumption |
|--------------------------------------|---|
| Demand 2 setting 2 (factory setting) | Approx. 40%                                   |

★ Other protection control functions have precedence over the above operation.

## 5.4 Heating Operation Prohibition

Heating operation is prohibited above 75°F ambient temperature.

## 6. Outline of Control (Indoor Unit)

### 6.1 Drain Pump Control

- The drain pump is controlled by the ON/OFF buttons (4 button (1) - (4) given in the figure below).

#### 6.1.1 When the Float Switch is Tripped While the Cooling Thermostat is ON:

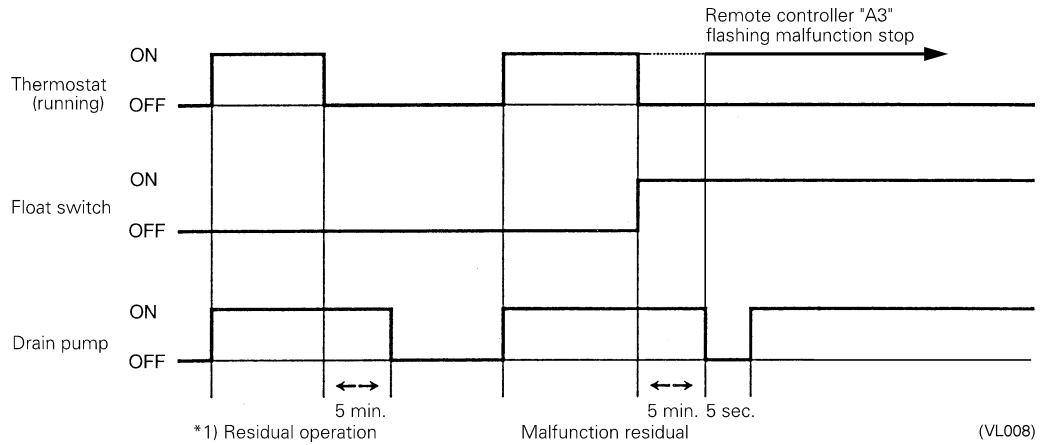

- \* 1. The objective of residual operation is to completely drain any moisture adhering to the fin of the indoor unit heat exchanger when the thermostat goes off during cooling operation.

#### 6.1.2 When the Float Switch is Tripped While Cooling OFF by Thermostat:

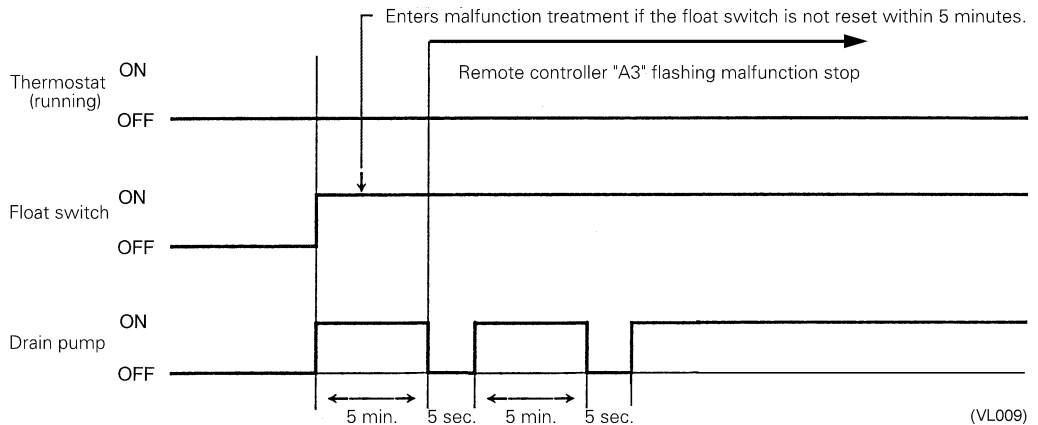

### 6.1.3 When the Float Switch is Tripped During Heating Operation:

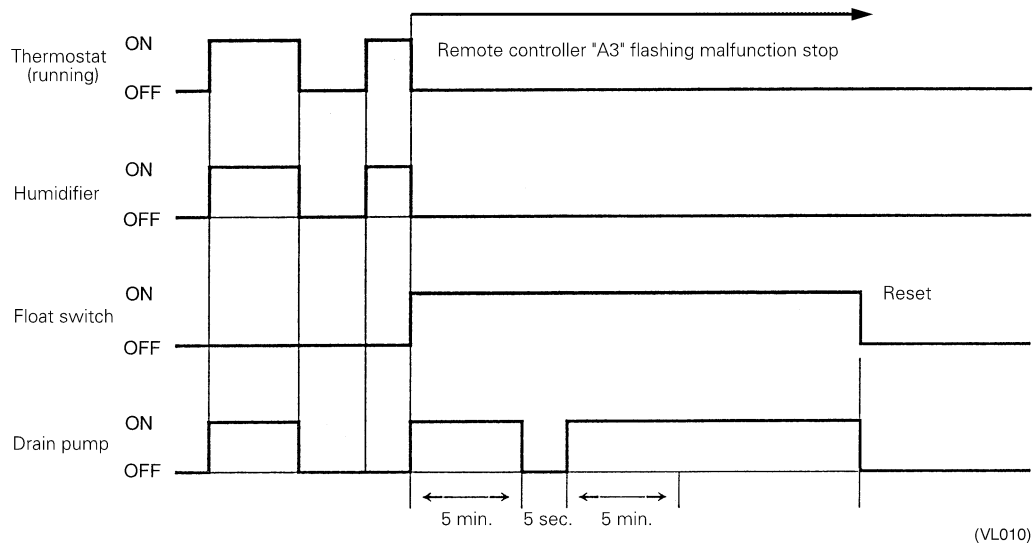

During heating operation, if the float switch is not reset even after the 5 minutes operation, 5 seconds stop, 5 minutes operation cycle ends, operation continues until the switch is reset.

### 6.1.4 When the Float Switch is Tripped and “AF” is Displayed on the Remote Controller:

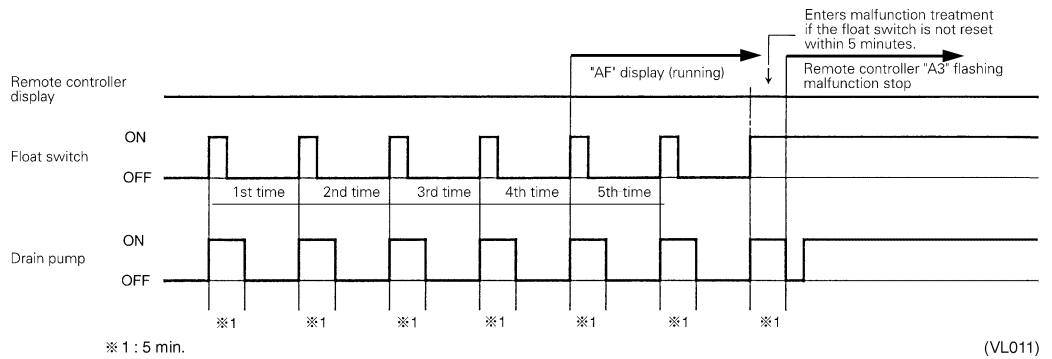

**Note:** If the float switch is tripped five times in succession, a drain malfunction is determined to have occurred. “AF” is then displayed as operation continues.

## 6.2 Thermostat Sensor in Remote Controller

Temperature is controlled by both the thermostat sensor in remote controller and air suction thermostat in the indoor unit. (This is however limited to when the field setting for the thermostat sensor in remote controller is set to "Use.")

### Cooling

If there is a significant difference in the preset temperature and the suction temperature, fine adjustment control is carried out using a body thermostat sensor, or using the sensor in the remote controller near the position of the user when the suction temperature is near the preset temperature.

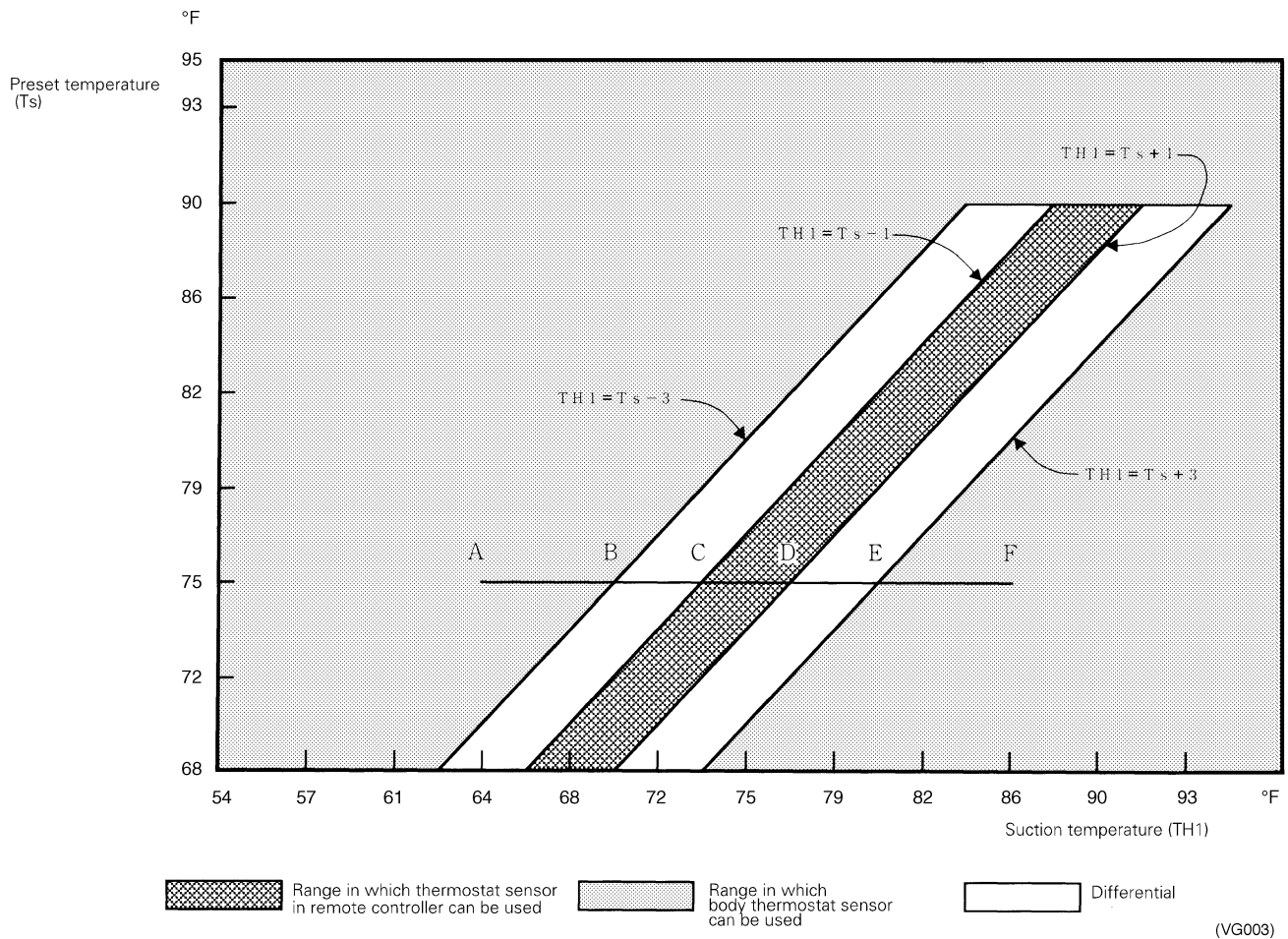

#### ■ Ex: When cooling

**Assuming the preset temperature in the figure above is 75°F, and the suction temperature has changed from 64°F to 86°F (A → F):**

(This example also assumes there are several other air conditioners, the VRV system is off, and that temperature changes even when the thermostat sensor is off.)

Body thermostat sensor is used for temperatures from 64°F to 73°F (A → C).

Remote controller thermostat sensor is used for temperatures from 73°F to 81°F (C → E).

Body thermostat sensor is used for temperatures from 81°F to 86°F (E → F).

**And, assuming suction temperature has changed from 86°F to 64°F (F → A):**

Body thermostat sensor is used for temperatures from 86°F to 77°F (F → D).

Remote controller thermostat sensor is used for temperatures from 77°F to 70°F (D → B).

Body thermostat sensor is used for temperatures from 70°F to 64°F (B → A).

## Heating

When heating, the hot air rises to the top of the room, resulting in the temperature being lower near the floor where the occupants are. When controlling by body thermostat sensor only, the unit may therefore be turned off by the thermostat before the lower part of the room reaches the preset temperature. The temperature can be controlled so the lower part of the room where the occupants are doesn't become cold by widening the range in which thermostat sensor in remote controller can be used so that suction temperature is higher than the preset temperature.

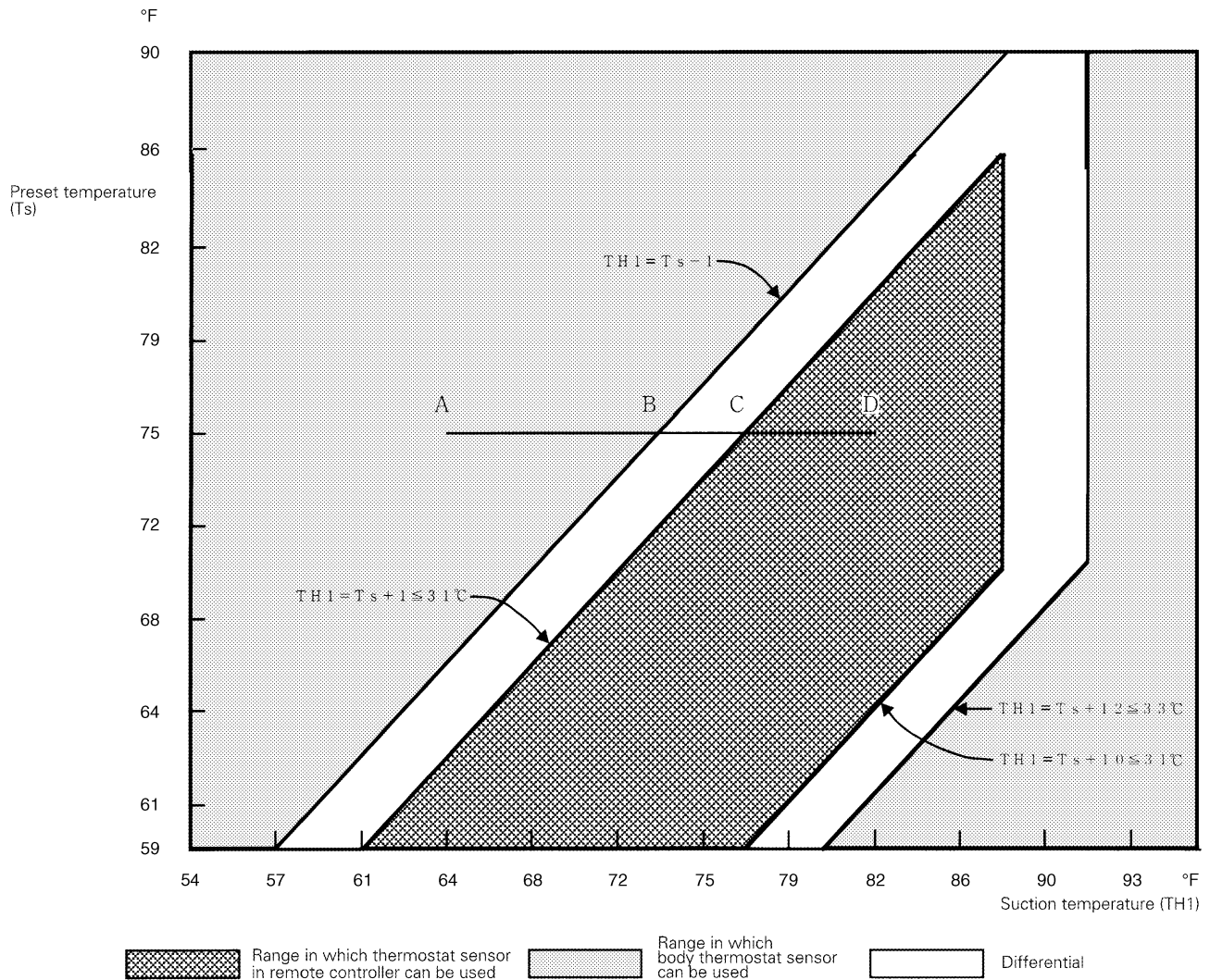

(V2769)

### ■ Ex: When heating

**Assuming the preset temperature in the figure above is 75°F, and the suction temperature has changed from 64°F to 82°F (A → D):**

(This example also assumes there are several other air conditioners, the VRV system is off, and that temperature changes even when the thermostat sensor is off.)

Body thermostat sensor is used for temperatures from 64°F to 77°F (A → C).

Remote controller thermostat sensor is used for temperatures from 77°F to 82°F (C → D).

**And, assuming suction temperature has changed from 82°F to 64°F (D → A):**

Remote controller thermostat sensor is used for temperatures from 82°F to 73°F (D → B).

Body thermostat sensor is used for temperatures from 73°F to 64°F (B → A).



## 6.3 Freeze Prevention

### Freeze Prevention by Off Cycle (Indoor Unit)

When the temperature detected by liquid pipe temperature thermistor (R2T) of the indoor unit heat exchanger drops too low, the unit enters freeze prevention operation in accordance with the following conditions, and is also set in accordance with the conditions given below.

Conditions for starting freeze prevention: Temperature is 30°F or less for total of 40 min., or temperature is 23°F or less for total of 10 min.

Conditions for stopping freeze prevention: Temperature is 45°F or more for 10 min. continuously

Ex: Case where temperature is 23°F or less for total of 10 min.

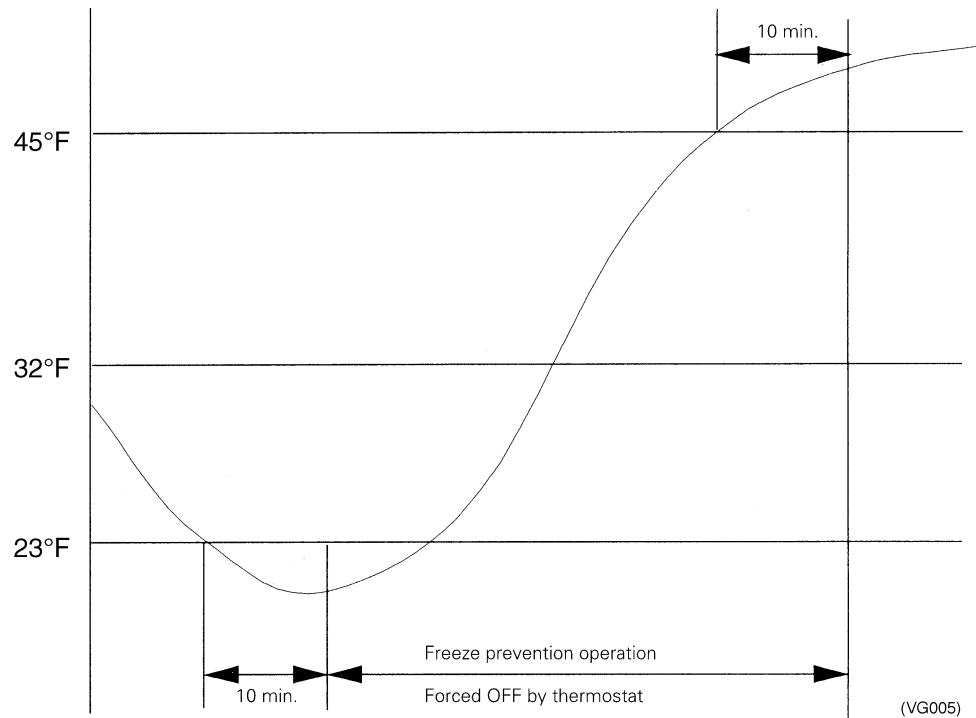

# Part 5

# Test Operation

- 1. Test Operation ..... 64
  - 1.1 Procedure and Outline ..... 64
  - 1.2 Operation When Power is Turned On ..... 67
- 2. Outdoor Unit PC Board Layout ..... 68
- 3. Field Setting ..... 69
  - 3.1 Field Setting from Remote Controller ..... 69
  - 3.2 Field Setting from Outdoor Unit..... 81

# 1. Test Operation

## 1.1 Procedure and Outline

Follow the following procedure to conduct the initial test operation after installation.

### 1.1.1 Check Work Prior to Turn Power Supply on

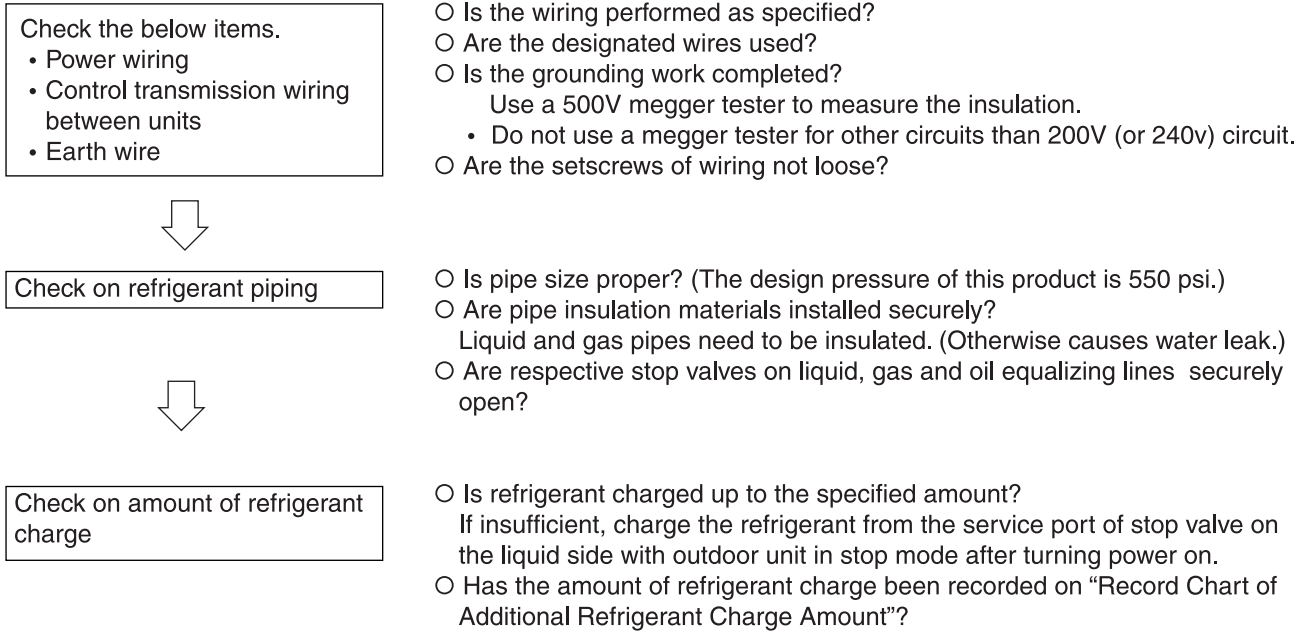

(V3055)

### 1.1.2 Turn Power on

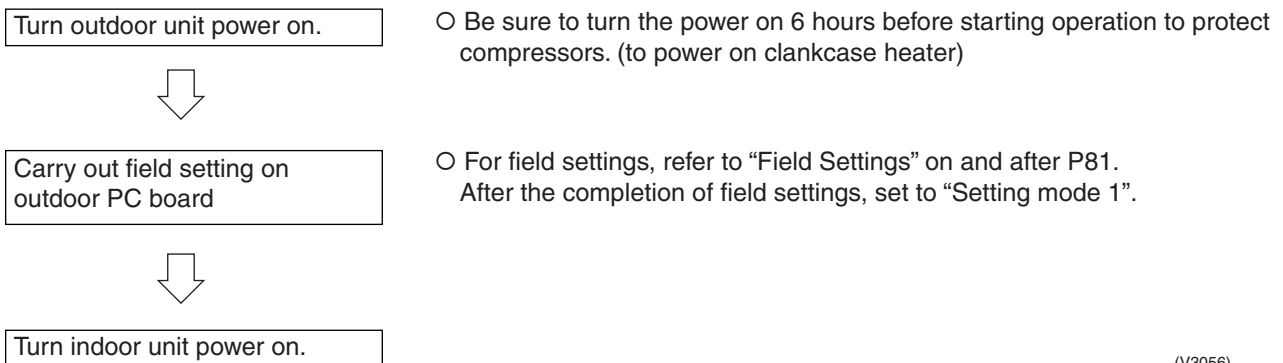

(V3056)

### 1.1.3 Check Operation

- \* During check operation, mount front panel to avoid the misjudging.
- \* Check operation is mandatory for normal unit operation.  
(When the check operation is not executed, alarm code "U3" will be displayed.)

Press and hold the TEST OPERATION button (BS4) on outdoor unit PC board for 5 seconds.



Check on operation

- The test operation is started automatically.
- The following judgements are conducted within 15 minutes.
  - "Check for wrong wiring"
  - "Check refrigerant for over charge"
  - "Check stop valve for not open"
  - Pipe length automatic judgement
- The following indications are conducted while in test operation.
  - LED lamp on outdoor unit PC board — H2P flickers (test operation)
  - Remote controller — Indicates "On Centralized Control" on upper right.  
Indicates "Test Operation" on lower left

(V3057)

On completion of test operation, LED on outdoor unit PC board displays the following.  
 H3P ON: Normal completion  
 H2P and H3P ON: Abnormal completion → Check the indoor unit remote controller for abnormal display and correct it.

In the case of multi-outdoor-unit system, make setting on the master unit PC board. (Setting with the slave unit is disabled.)  
 [LED display in the case of multi-outdoor-unit system] (Same as that in emergency operation)

\* Discriminate the operating status of the master unit/slave units through the following LED display.

LED display (○:ON ●:OFF ◐:Blink)  
 H1P — — — H7P H8P  
 Master: ● ● ○ ● ● ● ● ○  
 Slave : ● ● ● ● ● ● ● ◐  
 (Factory set)

## Malfunction code

In case of an alarm code displayed on remote controller:

| Cause of trouble due to faulty installation work                                  | Alarm code           | Countermeasure   |
|---|----------------------|--|
| Closed stop valve of outdoor unit   | E3<br>E4<br>F3<br>UF | In case of RXYQ72M, 96M Single outdoor installation<br>Liquid side stop valve : Open<br>Gas side stop valve : Open<br>Oil equalizing pipe stop valve : Close<br>In case of RXYQ144M, 168M, 192M Multi outdoor installation<br>Liquid side stop valve : Open<br>Gas side stop valve : Open<br>Oil equalizing pipe stop valve : Open |
| Reversed phase in power cable connection for outdoor unit                         | U1                   | Change connection of two wires among three for correct phasing.  |
| Electric power for outdoor or indoor unit is not supplied. (Including open phase) | U4                   | Check that the power cable for outdoor unit is connected properly.   |
| Incorrect wiring between units  | UF                   | Check that the wiring between units corresponds correctly to refrigerant piping system.  |
| Refrigerant overcharge  | E3<br>F6<br>UF       | Compute again optimum amount of refrigerant to be added based on the piping length, then, collect the excessive amount by using refrigerant collector to make the refrigerant amount proper.   |
| Insufficient refrigerant  | E4<br>F3             | - Check that additional charging has been carried out.<br>- Compute again the refrigerant amount to be added based on the piping length, and charge proper amount of refrigerant additionally.   |

### 1.1.4 Confirmation on Normal Operation

- Conduct normal unit operation after the check operation has been completed.  
(When outdoor air temperature is 75°F or higher, the unit can not be operated with heating mode. See the instruction manual attached.)  
Confirm that the indoor/outdoor units can be operated normally.  
(When an abnormal noise due to liquid compression by the compressor can be heard, stop the unit immediately, and turn on the crankcase heater to heat up it sufficiently, then start operation again.)
- Operate indoor unit one by one to check that the corresponding outdoor unit operates.
- Confirm that the indoor unit discharges cold air (or warm air).
- Operate the air direction control button and flow rate control button to check the function of the devices.

## 1.2 Operation When Power is Turned On

### 1.2.1 When Turning On Power First Time

The unit cannot be run for up to 12 minutes to automatically set the master power and address (indoor-outdoor address, etc.).

#### Status

Outdoor unit

Test lamp H2P .... Blinks

Can also be set during operation described above.

Indoor unit

If ON button is pushed during operation described above, the "UH" malfunction indicator blinks.

(Returns to normal when automatic setting is complete.)

### 1.2.2 When Turning On Power The Second Time and Subsequent

Tap the RESET button on the outdoor unit PC board. Operation becomes possible for about 2 minutes. If you do not push the RESET button, the unit cannot be run for up to 10 minutes to automatically set master power.

#### Status

Outdoor unit

Test lamp H2P .... Blinks

Can also be set during operation described above.

Indoor unit

If ON button is pushed during operation described above, the operation lamp lights but the compressor does not operate. (Returns to normal when automatic setting is complete.)

### 1.2.3 When an Indoor Unit or Outdoor unit Has Been Added, or Indoor or Outdoor Unit PC Board Has Been Changed

Be sure to push and hold the RESET button for 5 seconds. If not, the addition cannot be recognized. In this case, the unit cannot be run for up to 12 minutes to automatically set the address (indoor-outdoor address, etc.)

#### Status

Outdoor unit

Test lamp H2P .... ON

Can also be set during operation described above.

Indoor unit

If ON button is pushed during operation described above, the "UH" or "U4" malfunction indicator blinks. (Returns to normal when automatic setting is complete.)

## 2. Outdoor Unit PC Board Layout

### Outdoor Unit PC Board

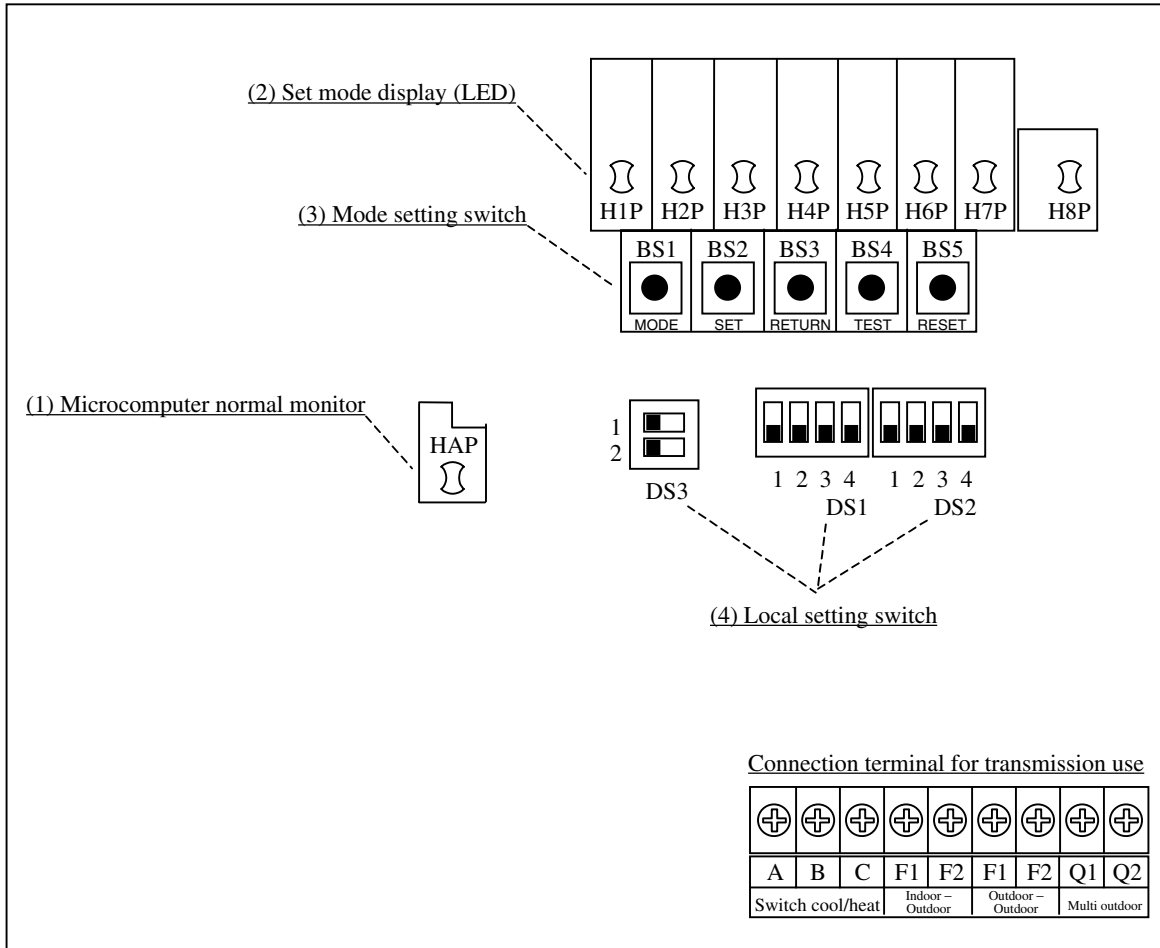

(V3054)

- (1) Microcomputer normal monitor  
This monitor blinks while in normal operation, and turns on or off when a malfunction occurs.
- (2) Set mode display (LED)  
LEDs display mode according to the setting.
- (3) Mode setting switch  
Used to change mode.
- (4) Local setting switch  
Used to make local settings.

## 3. Field Setting

### 3.1 Field Setting from Remote Controller

Individual function of indoor unit can be changed from the remote controller. At the time of installation or after service inspection / repair, make the local setting in accordance with the following description.



Wrong setting may cause malfunction.

(When optional accessory is mounted on the indoor unit, setting for the indoor unit may be required to change. Refer to information in the option handbook.)

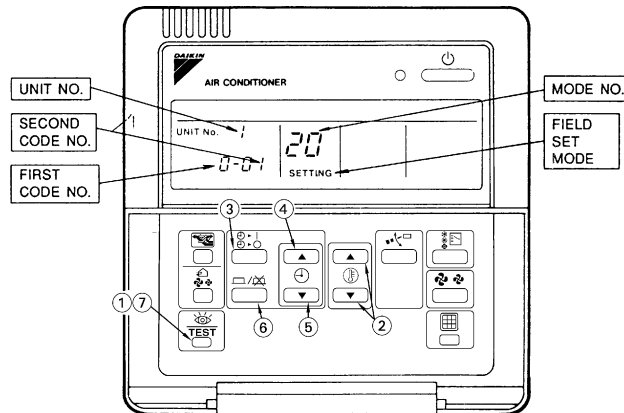



#### 3.1.1 Wired Remote Controller <BRC1C71>



2P068938-1

1. When in the normal mode, push the  button for 4 seconds or more, and operation then enters the “field set mode.”
2. Select the desired “mode No.” with the  button.
3. During group control and you want to set by each individual indoor unit (when mode No. 20, 21, 22, 23, 25 has been selected), push the time mode  button and select the “indoor unit No.” to be set.

Note: This operation is not required when setting as a group.

4. Push the  button and select the first code No.
5. Push the  button and select the second code No.
6. Push the timer  button one time and “define” the currently set contents.
7. Push the  button to return to the normal mode.

(Example)

When setting the filter sign time to “Filter Dirtiness-High” in all group unit setting, set the Mode No. to “10”, Mode setting No. to “0” and setting position No. to “02”.







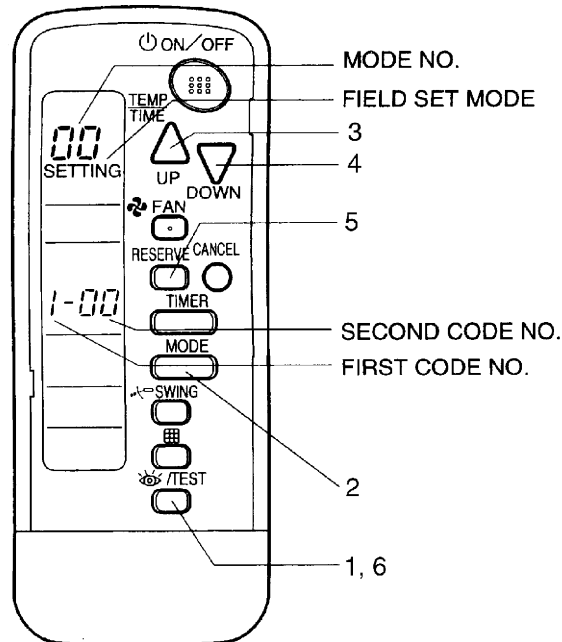

### 3.1.2 Wireless Remote Controller - Indoor Unit

BRC7C812  
BRC4C82  
BRC7E818  
BRC7E83



(V2770)

1. When in the normal mode, push the  button for 4 seconds or more, and operation then enters the "field set mode."
2. Select the desired "mode No." with the  button.
3. Pushing the  button, select the first code No.
4. Pushing the  button, select the second code No.
5. Push the timer  button and check the settings.
6. Push the  button to return to the normal mode.

(Example)

When setting the filter sign time to "Filter Dirtiness-High" in all group unit setting, set the Mode No. to "10", Mode setting No. to "0" and setting position No. to "02".

### 3.1.3 Simplified Remote Controller

BRC2A71

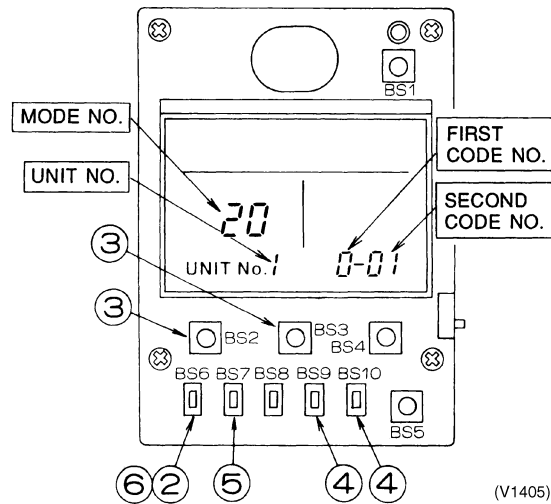

■ Group No. setting by simplified remote controller.

1. Remove the cover of remote controller.
2. While in normal mode, press the [BS6] BUTTON (field set) to enter the FIELD SET MODE.
3. Select the mode No. [00] with [BS2] BUTTON (temperature setting ▲) and [BS3] BUTTON (temperature setting ▼).
4. Select the group No. with [BS9] BUTTON (set A) and [BS10] BUTTON (set B). (Group Nos. increase in the order of 1-00, 1-01.....1-15, 2-00,.....4-15. However, the unified ON/OFF controller displays only group No. set within the range of control.)
5. Press [BS7] BUTTON (set/cancel) to set group No.
6. Press [BS6] BUTTON (field set) to return to the NORMAL MODE.

### 3.1.4 Setting Contents and Code No. – VRV Unit

| VRV system indoor unit settings | Mode No. Note 2 | Setting Switch No. | Setting Contents  | Second Code No.(Note 3)  |                                     |                        |                |                            |                                  |      |                    |      |  |      |  |      |  |      |  |
|---------------------------------|-----------------|--------------------|---|--|-------------------------------------|------------------------|----------------|----------------------------|----------------------------------|------|--------------------|------|--|------|--|------|--|------|--|
|                                 |                 |                    |   | 01   |                                     | 02                     |                | 03                         |                                  | 04   |                    |      |  |      |  |      |  |      |  |
| 10(20)                          | 0               |                    | Filter contamination heavy/light (Setting for display time to clean air filter) (Sets display time to clean air filter to half when there is heavy filter contamination.) | Super long life filter   | Light                               | Approx. 10,000 hrs.    | Heavy          | Approx. 5,000 hrs.         | —                                |      | —                  |      |  |      |  |      |  |      |  |
|                                 |                 |                    |   | Long life filter   |                                     | Approx. 2,500 hrs.     |                | Approx. 1,250 hrs.         |                                  |      |                    |      |  |      |  |      |  |      |  |
|                                 |                 |                    |   | Standard filter  |                                     | Approx. 200 hrs.       |                | Approx. 100 hrs.           |                                  |      |                    |      |  |      |  |      |  |      |  |
|                                 | 1               |                    | Long life filter type   | Long life filter   |                                     | Super long life filter |                | —                          |                                  | —    |                    |      |  |      |  |      |  |      |  |
|                                 | 2               |                    | Thermostat sensor in remote controller  | Use  |                                     | No use                 |                | —                          |                                  | —    |                    |      |  |      |  |      |  |      |  |
|                                 | 3               |                    | Display time to clean air filter calculation (Set when filter sign is not to be displayed.)   | Display  |                                     | No display             |                | —                          |                                  | —    |                    |      |  |      |  |      |  |      |  |
|                                 | 12(22)          | 0                  |   | Optional accessories output selection (field selection of output for adaptor for wiring) | Indoor unit turned ON by thermostat |                        |                |                            | Operation output                 |      | Malfunction output |      |  |      |  |      |  |      |  |
|                                 |                 |                    |   |  | Forced OFF                          |                        | ON/OFF control |                            | External protection device input |      | —                  |      |  |      |  |      |  |      |  |
|                                 |                 | 1                  |   | ON/OFF input from outside (Set when ON/OFF is to be controlled from outside.)            | 2°F                                 |                        | 1°F            |                            | —                                |      | —                  |      |  |      |  |      |  |      |  |
|                                 |                 | 2                  |   | Thermostat differential changeover (Set when remote sensor is to be used.) Note6         | LL                                  |                        | Set fan speed  |                            | —                                |      | —                  |      |  |      |  |      |  |      |  |
| 3                               |                 |                    | OFF by thermostat fan speed   | 01:0   |                                     | 02:1                   |                | 03:2                       |                                  | 04:3 |                    | 05:4 |  | 06:5 |  | 07:6 |  | 08:7 |  |
| 4                               |                 |                    | Automatic mode differential (automatic temperature differential setting for VRV system heat recovery series cool/heat)  | Not equipped   |                                     | Equipped               |                | —                          |                                  | —    |                    |      |  |      |  |      |  |      |  |
| 13(23)                          | 0               |                    | High air outlet velocity (Set when installed in place with ceiling higher than 2.7 m.)  | N  |                                     | H                      |                | S                          |                                  | —    |                    |      |  |      |  |      |  |      |  |
|                                 |                 |                    |   | F (4 directions)   |                                     | T (3 directions)       |                | W (2 directions)           |                                  | —    |                    |      |  |      |  |      |  |      |  |
|                                 | 1               |                    | Selection of air flow direction (Set when a blocking pad kit has been installed.)   | Equipped   |                                     | Not equipped           |                |                            |                                  | —    |                    |      |  |      |  |      |  |      |  |
|                                 | 3               |                    | Air flow direction adjustment (Set at installation of decoration panel.)  | Draft prevention   |                                     | Standard               |                | Ceiling Soiling prevention |                                  | —    |                    |      |  |      |  |      |  |      |  |
|                                 | 4               |                    | Field set air flow position setting   | Standard   |                                     | Optional accessory 1   |                | Optional accessory 2       |                                  | —    |                    |      |  |      |  |      |  |      |  |
|                                 | 5               |                    | Field set fan speed selection (fan speed control by air discharge outlet for phase control)   | Not equipped   |                                     | Equipped               |                | —                          |                                  | —    |                    |      |  |      |  |      |  |      |  |
| 15(25)                          | 1               |                    | Thermostat OFF excess humidity  | Not equipped   |                                     | Equipped               |                | —                          |                                  | —    |                    |      |  |      |  |      |  |      |  |
|                                 |                 |                    |   | Not equipped   |                                     | Equipped               |                | —                          |                                  | —    |                    |      |  |      |  |      |  |      |  |
|                                 | 2               |                    | Direct duct connection (when the indoor unit and heat reclaim ventilation unit are connected by duct directly.) *Note 6   | Not equipped   |                                     | Equipped               |                | —                          |                                  | —    |                    |      |  |      |  |      |  |      |  |
|                                 | 3               |                    | Drain pump humidifier interlock selection   | Not equipped   |                                     | Equipped               |                | —                          |                                  | —    |                    |      |  |      |  |      |  |      |  |
|                                 | 5               |                    | Field set selection for individual ventilation setting by remote controller   | Not equipped   |                                     | Equipped               |                | —                          |                                  | —    |                    |      |  |      |  |      |  |      |  |
|                                 | 6               |                    | Field set selection for individual ventilation setting by remote controller   | Not equipped   |                                     | Equipped               |                | —                          |                                  | —    |                    |      |  |      |  |      |  |      |  |



- Note:**
- Settings are made simultaneously for the entire group, however, if you select the mode No. inside parentheses, you can also set by each individual unit. Setting changes however cannot be checked except in the individual mode for those in parentheses.
  - The mode numbers inside parentheses cannot be used by wireless remote controllers, so they cannot be set individually. Setting changes also cannot be checked.
  - Marked   are factory set.
  - Do not make settings other than those described above. Nothing is displayed for functions the indoor unit is not equipped with.
  - "88" may be displayed to indicate the remote controller is resetting when returning to the normal mode.
  - This setting is only applicable to FXFQ and FXHQ type.
  - If the setting mode to "Equipped", heat reclaim ventilation fan conducts the fan residual operation by linking to indoor unit.

### 3.1.5 Applicable range of Field setting

|   | Ceiling mounted cassette type | Slim Ceiling mounted duct type | Ceiling mounted built-in type | Ceiling mounted duct type | Ceiling Suspended type | Wall mounted type | Floor standing type | Concealed Floor standing type |
|---|-------------------------------|--------------------------------|-------------------------------|---------------------------|------------------------|-------------------|---------------------|-------------------------------|
|   | Multi flow                    |                                | FXSQ                          | FXMQ                      | FXHQ                   | FXAQ              | FXLQ                | FXNQ                          |
|   | FXFQ                          |                                |                               |                           |                        |                   |                     |                               |
| Filter sign   | ○                             | ○                              | ○                             | ○                         | ○                      | ○                 | ○                   | ○                             |
| Ultra long life filter sign                         | ○                             | —                              | —                             | —                         | —                      | —                 | —                   | —                             |
| Remote controller thermostat sensor                 | ○                             | ○                              | ○                             | ○                         | ○                      | ○                 | ○                   | ○                             |
| Set fan speed when thermostat OFF                   | ○                             | ○                              | ○                             | ○                         | ○                      | ○                 | ○                   | ○                             |
| Air flow adjustment Ceiling height                  | ○                             | —                              | —                             | —                         | ○                      | —                 | —                   | —                             |
| Air flow direction                                  | ○                             | —                              | —                             | —                         | —                      | —                 | —                   | —                             |
| Air flow direction adjustment (Down flow operation) | —                             | —                              | —                             | —                         | —                      | —                 | —                   | —                             |
| Air flow direction adjustment range                 | ○                             | —                              | —                             | —                         | —                      | —                 | —                   | —                             |
| Field set fan speed selection                       | ○                             | ○*1                            | —                             | —                         | ○                      | —                 | —                   | —                             |

\*1 Static pressure selection

### 3.1.6 Detailed Explanation of Setting Modes

#### Filter Sign Setting

If switching the filter sign ON time, set as given in the table below.

##### Set Time

| Setting             | Filter Specs. | Standard | Long Life  | Ultra Long Life Filter |
|---------------------|---------------|----------|------------|------------------------|
| Contamination Light |               | 200 hrs. | 2,500 hrs. | 10,000 hrs.            |
| Contamination Heavy |               | 100 hrs. | 1,250 hrs. | 5,000 hrs.             |

#### Ultra-Long-Life Filter Sign Setting

When a Ultra-long-life filter is installed, the filter sign timer setting must be changed.

##### Setting Table

| Mode No. | Setting Switch No. | Setting Position No. | Setting                    |
|----------|--------------------|----------------------|----------------------------|
| 10 (20)  | 1                  | 01                   | Long-Life Filter           |
|          |                    | 02                   | Ultra-Long-Life Filter (1) |
|          |                    | 03                   | —                          |

**External ON/OFF input**

This input is used for "ON / OFF operation" and "Protection device input" from the outside. The input is performed from the T1-T1 terminal of the operation terminal block (X1A) in the electric component box.

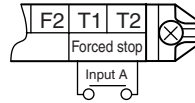
**Setting Table**

| Mode No. | Setting Switch No. | Setting Position No. | Operation by input of the signal A   |
|----------|--------------------|----------------------|--|
| 12 (22)  | 1                  | 01                   | ON: Forced stop (prohibition of using the remote controller)<br>OFF: Permission of using the remote controller         |
|          |                    | 02                   | OFF → ON: Permission of operation<br>ON → OFF: Stop  |
|          |                    | 03                   | ON: Operation<br>OFF: The system stops, then the applicable unit indicates "A0". The other indoor units indicate "U9". |

**Fan Speed Changeover When Thermostat is OFF**

By setting to "Set Fan Speed," you can switch the fan speed to the set fan speed when the heating thermostat is OFF.

\* Since there is concern about draft if using "fan speed up when thermostat is OFF," you should take the setup location into consideration.

**Setting Table**

| Mode No. | First Code No. | Second Code No. | Setting       |
|----------|----------------|-----------------|---------------|
| 12(22)   | 3              | 01              | LL Fan Speed  |
|          |                | 02              | Set Fan Speed |

**Auto Restart after Power Failure Reset**

For the air conditioners with no setting for the function (same as factory setting), the units will be left in the stop condition when the power supply is reset automatically after power failure reset or the main power supply is turned on again after once turned off. However, for the air conditioners with the setting, the units may start automatically after power failure reset or the main power supply turned on again (return to the same operation condition as that of before power failure).

For the above reasons, when the unit is set enabling to utilize "Auto restart function after power failure reset", utmost care should be paid for the occurrence of the following situation.



- Caution**
- 1. The air conditioner starts operation suddenly after power failure reset or the main power supply turned on again. Consequently, the user might be surprised (with question for the reason why).**
  - 2. In the service work, for example, turning off the main power switch during the unit is in operation, and turning on the switch again after the work is completed start the unit operation (the fan rotates).**

**Air Flow Adjustment - Ceiling height**

Make the following setting according to the ceiling height. The setting position No. is set to "01" at the factory.

■ **In the Case of FXAQ07~24, FXHQ12~36**

| Mode No. | Setting Switch No. | Setting Position No. | Setting                            |
|----------|--------------------|----------------------|------------------------------------|
| 13(23)   | 0                  | 01                   | Wall-mounted type: Standard        |
|          |                    | 02                   | Wall-mounted type: Slight increase |
|          |                    | 03                   | Wall-mounted type: Normal increase |

■ **In the Case of FXFQ12~36**

| Mode No. | First code No. | Second code No. | Setting            | Ceiling height   |                  |                  |
|----------|----------------|-----------------|--------------------|------------------|------------------|------------------|
|          |                |                 |                    | 4-way Outlets    | 3-way Outlets    | 2-way Outlets    |
| 13 (23)  | 0              | 01              | Standard (N)       | Lower than 2.7 m | Lower than 3.0 m | Lower than 3.5 m |
|          |                | 02              | High Ceiling (H)   | Lower than 3.0 m | Lower than 3.3 m | Lower than 3.8 m |
|          |                | 03              | Higher Ceiling (S) | Lower than 3.5 m | Lower than 3.5 m | —                |

**Air Flow Direction Setting**

Set the air flow direction of indoor units as given in the table below. (Set when optional air outlet blocking pad has been installed.) The second code No. is factory set to "01."

**Setting Table**

| Mode No. | First Code No. | Second Code No. | Setting                  |
|----------|----------------|-----------------|--------------------------|
| 13 (23)  | 1              | 01              | F : 4-direction air flow |
|          |                | 02              | T : 3-direction air flow |
|          |                | 03              | W : 2-direction air flow |

**Setting of Air Flow Direction Adjustment Range**

Make the following air flow direction setting according to the respective purpose.

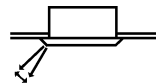

(S2537)

**Setting Table**

| Mode No. | First Code No. | Second Code No. | Setting                               |
|----------|----------------|-----------------|---------------------------------------|
| 13 (23)  | 4              | 01              | Upward (Draft prevention)             |
|          |                | 02              | Standard                              |
|          |                | 03              | Downward (Ceiling soiling prevention) |







**Air Flow Rate Switching at Discharge Grille for Field Air Flow Rate Switching**

When the optional parts (high performance filter, etc.) is installed, sets to change fan speed for securing air flow rate.

Follow the instruction manual for the optional parts to enter the setting numbers.

### 3.1.7 Centralized Control Group No. Setting

#### BRC1C Type



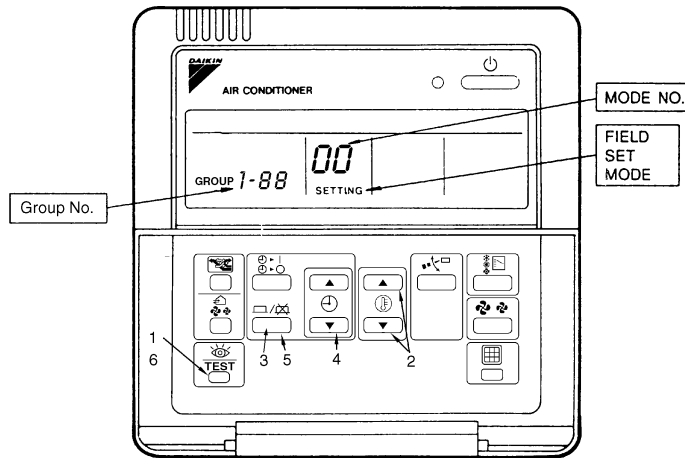



- If carrying out centralized control by central remote controller or unified ON/OFF controller, group No. must be set for each group individually by remote controller.
- Group No. setting by remote controller for centralized control
  1. When in the normal mode, push the  button for 4 seconds or more, and operation then enters the “field setting mode.”
  2. Set mode No. “00” with the  button. \*
  3. Push the  button to inspect the group No. display.
  4. Set the group No. for each group with the  button (The group No. increases in the manner of 1-00, 1-01, ..., 1-15, 2-00, ... 4-15. However, the unified ON/OFF controller displays only the group No. within the range selected by the switch for setting each address.)
  5. Push the timer  button to define the selected group No.
  6. Push the  button to return to the normal mode.



(S1095)

- Even if not using a remote controller, connect the remote controller when setting the group No., set the group No. for centralized control, and disconnect after making the setting.
- Set the group No. after turning on the power supply for the central remote controller, unified ON/OFF controller, and indoor unit.

**BRC7C Type**  
**BRC4C Type**  
**BRC7E Type**

- Group No. setting by wireless remote controller for centralized control
1. When in the normal mode, push  button for 4 seconds or more, and operation then enters the "field set mode."
  2. Set mode No. "00" with  button.
  3. Set the group No. for each group with   button (advance/backward).
  4. Enter the selected group numbers by pushing  button.
  5. Push  button and return to the normal mode.

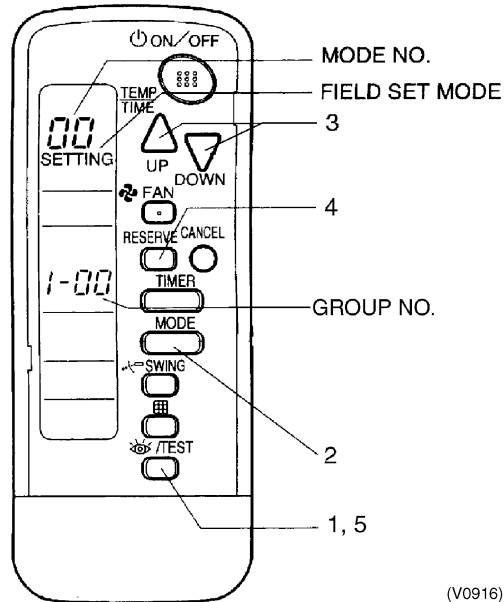

(V0916)



**Group No. Setting Example**

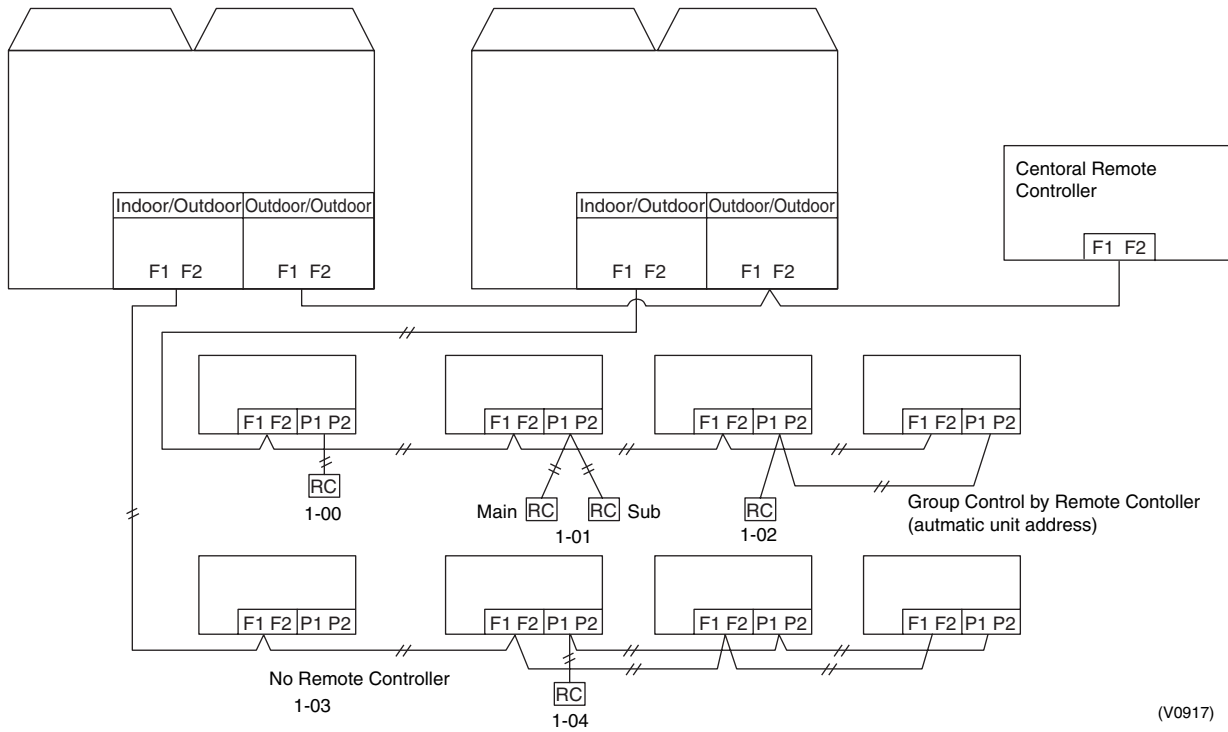

(V0917)



**Caution**

When turning the power supply on, the unit may often not accept any operation while "88" is displaying after all indications were displayed once for about 1 minute on the liquid crystal display. This is not an operative fault.

### 3.1.8 Setting of Operation Control Mode from Remote Controller (Local Setting)

The operation control mode is compatible with a variety of controls and operations by limiting the functions of the operation remote controller. Furthermore, operations such as remote controller ON/OFF can be limited in accordance with the combination conditions. (Refer to information in the table below.)

Centralized controller is normally available for operations. (Except when centralized monitor is connected)

### 3.1.9 Contents of Control Modes

Twenty modes consisting of combinations of the following five operation modes with temperature and operation mode setting by remote controller can be set and displayed by operation modes 0 through 19.

- ◆ ON/OFF control impossible by remote controller  
Used when you want to turn on/off by central remote controller only.  
(Cannot be turned on/off by remote controller.)
- ◆ OFF control only possible by remote controller  
Used when you want to turn on by central remote controller only, and off by remote controller only.
- ◆ Centralized  
Used when you want to turn on by central remote controller only, and turn on/off freely by remote controller during set time.
- ◆ Individual  
Used when you want to turn on/off by both central remote controller and remote controller.
- ◆ Timer operation possible by remote controller  
Used when you want to turn on/off by remote controller during set time and you do not want to start operation by central remote controller when time of system start is programmed.

**How to Select Operation Mode**

Whether operation by remote controller will be possible or not for turning on/off, controlling temperature or setting operation mode is selected and decided by the operation mode given on the right edge of the table below.

**Example**

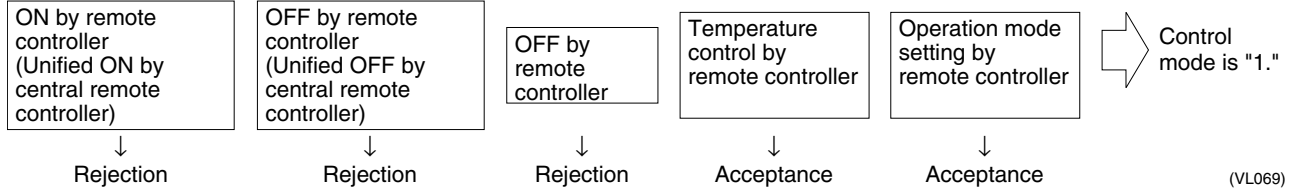

| Control mode                                   | Control by remote controller   |  |                     |                      |                        | Control mode |
|--|--|--|---------------------|----------------------|------------------------|--------------|
|  | Operation  |  | OFF                 | Temperature control  | Operation mode setting |              |
|  | Unified operation, individual operation by central remote controller, or operation controlled by timer | Unified OFF, individual stop by central remote controller, or timer stop |                     |                      |                        |              |
| ON/OFF control impossible by remote controller | Rejection (Example)  | Rejection (Example)  | Rejection (Example) | Rejection            | Acceptance             | 0            |
| OFF control only possible by remote controller |  |  |                     | Acceptance (Example) | Acceptance (Example)   | 1(Example)   |
| Centralized                                    | Acceptance   | Acceptance   | Acceptance          | Rejection            | Acceptance             | 2            |
| Individual                                     |  |  |                     | Acceptance           | Rejection              | Acceptance   |
| Timer operation possible by remote controller  | Acceptance (During timer at ON position only)  | Acceptance (During timer at ON position only)                            | Acceptance          | Rejection            | Acceptance             | 4            |
|  |  |  |                     | Acceptance           | Rejection              | Acceptance   |
|  |  |  |                     | Rejection            | Acceptance             | 6            |
|  |  |  |                     | Acceptance           | Acceptance             | 7 *1         |
|  |  |  |                     | Rejection            | Acceptance             | 8            |
|  |  |  |                     | Acceptance           | Acceptance             | 9            |
|  |  |  |                     | Rejection            | Acceptance             | 10           |
|  |  |  |                     | Acceptance           | Acceptance             | 11           |
|  |  |  |                     | Rejection            | Acceptance             | 12           |
|  |  |  |                     | Acceptance           | Acceptance             | 13           |
|  |  |  |                     | Rejection            | Acceptance             | 14           |
|  |  |  |                     | Acceptance           | Acceptance             | 15           |
|  |  |  |                     | Rejection            | Acceptance             | 16           |
|  |  |  |                     | Acceptance           | Acceptance             | 17           |
|  |  |  |                     | Rejection            | Acceptance             | 18           |
|  |  |  |                     | Acceptance           | Acceptance             | 19           |

Do not select "timer operation possible by remote controller" if not using a remote controller. Operation by timer is impossible in this case.

\*1. Factory setting

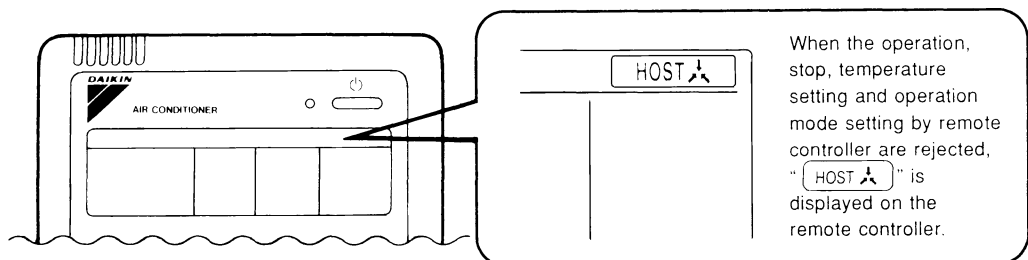

(VL070)

## 3.2 Field Setting from Outdoor Unit

### 3.2.1 Field Setting from Outdoor Unit

■ **Setting by dip switches**

The following field settings are made by dip switches on PC board.

| Dipswitch       |                   | Setting item       | Description   |
|-----------------|-------------------|--------------------|---|
| No.             | Setting           |                    |   |
| DS1-1           | ON                | Cool / Heat select | Used to set cool / heat select by remote controller equipped with outdoor unit. |
|                 | OFF (Factory set) |                    |   |
| DS1-2<br>~DS1-4 | ON                | Not used           | Do not change the factory settings.   |
|                 | OFF (Factory set) |                    |   |
| DS2-1<br>~4     | ON                | Not used           | Do not change the factory settings.   |
|                 | OFF (Factory set) |                    |   |
| DS3-1, 2        | ON                | Not used           | Do not change the factory settings.   |
|                 | OFF (Factory set) |                    |   |



**Caution**

**DIP switch Setting after changing the main P.C.Board(A1P) to spare parts P.C.B.**

When you change the main P.C.Board(A1P) to spare parts P.C.B., please carry out the following setting.



**DIP Switch Detail**

| DS No. | Item                           | Contents |  |          |        |
|--------|--------------------------------|----------|--|----------|--------|
| DS1-1  | Cool/Heat change over setting  | ON       | The Cool/Heat change over setting is carried out by COOL/HEAT changeover remote controller fitted to outdoor unit.     |          |        |
|        |                                | OFF      | The Cool/Heat change over setting is not carried out by COOL/HEAT changeover remote controller fitted to outdoor unit. |          |        |
| DS1-2  | Power supply setting           | ON       | 3 phase 200 Volt area  |          |        |
|        |                                | OFF      | 3 phase 400 Volt area  |          |        |
| DS1-3  | Cooling only/Heat-pump setting | ON       | Cooling only   |          |        |
|        |                                | OFF      | Heat-pump  |          |        |
| DS1-4  | Refrigerant classification     |          | R-22   | Not used | R-410A |
| DS2-1  |                                | DS1-4    | OFF  | ON       | OFF    |
|        |                                | DS2-1    | OFF  | OFF      | ON     |
| DS2-2  | Capacity setting               |          | 72, 96   |          |        |
| DS2-3  |                                | DS2-2    | OFF  |          |        |
|        |                                | DS2-3    | OFF  |          |        |
| DS2-4  |                                | DS2-4    | ON   |          |        |

\* If the DS1-4,DS2-1 setting(refrigerant classification) has not been carried out, error code "UA" is displayed and unit can not be operated.

■ **Setting by pushbutton switches**

The following settings are made by pushbutton switches on PC board.

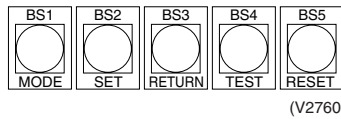

There are the following three setting modes.

① **Setting mode 1 (H1P off)**

Initial status (when normal) : Used to select the cool/heat setting. Also indicates during “abnormal”, “low noise control” and “demand control”.

② **Setting mode 2 (H1P on)**

Used to modify the operating status and to set program addresses, etc. Usually used in servicing the system.

③ **Monitor mode (H1P blinks)**

Used to check the program made in Setting mode 2.

■ **Mode changing procedure**

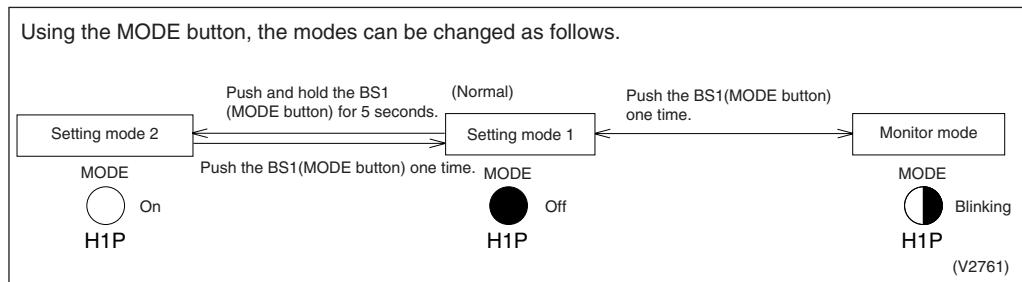

■ **Mode changing procedure**

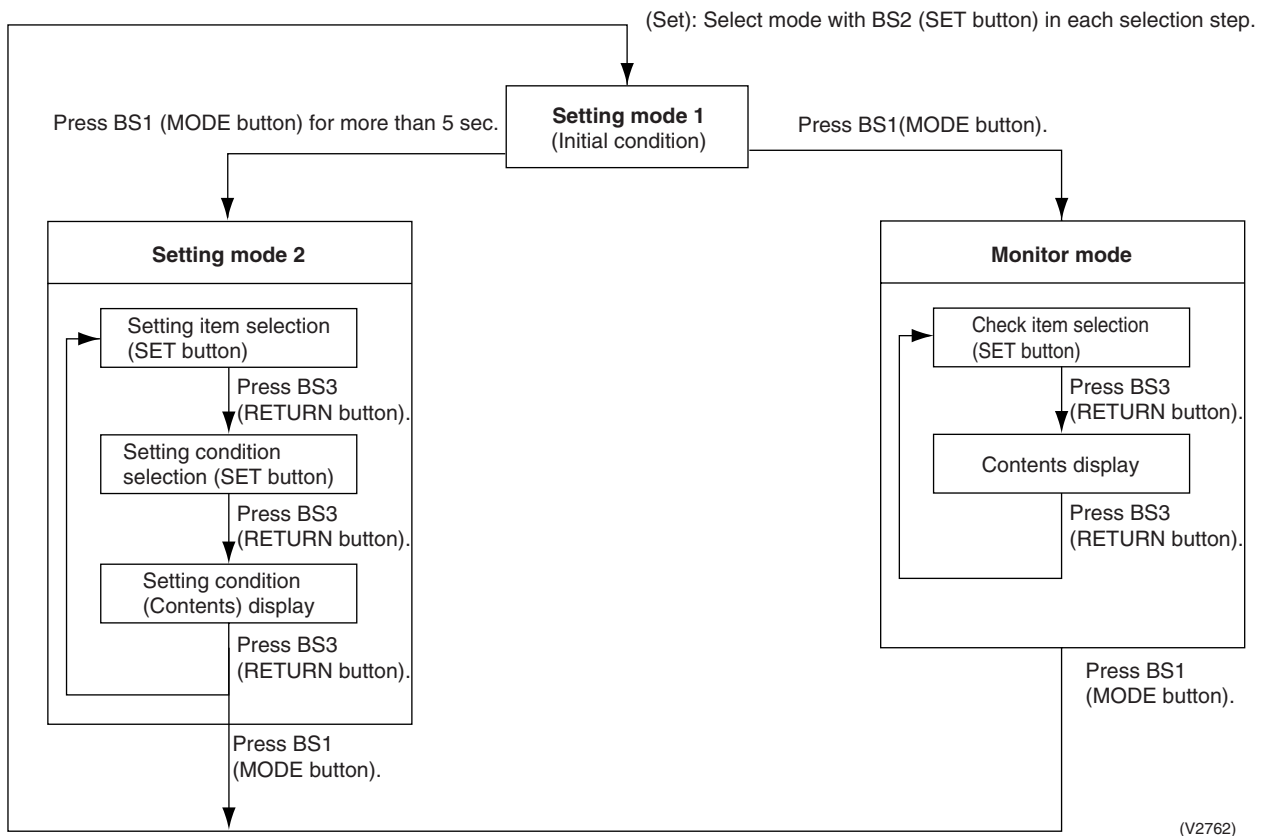

### a. "Setting mode 1"

Normally, "Setting mode 1" is set. In case of other status, push MODE button (BS1) one time and set to "Setting mode 1".

<Selection of setting items>

Push the SET button (BS2) and set LED display to a setting item you want.

- Regarding setting item No. 1,5,6, only the present status is displayed. For the respective description, refer to the table shown on lower right.
- The cool/heat selection setting can be changed on setting item 2, 3, 4. → After setting, push the RETURN button (BS3) and decide the item.

When the RETURN button (BS3) is pushed, the status becomes the initial status of "Setting mode 1".

(V2763)

○ : ON ● : OFF ◐ : Blink

| No. | Setting (displaying) item                        | LED display example |     |     |     |     |     |     |
|-----|--|---------------------|-----|-----|-----|-----|-----|-----|
|     |  | H1P                 | H2P | H3P | H4P | H5P | H6P | H7P |
| 1   | Display for malfunction / preparing / test run * | ●                   | ●   | ○   | ●   | ●   | ●   | ●   |
| 2   | C/H selector (individual)                        | ●                   | ●   | ○   | ●   | ●   | ●   | ●   |
| 3   | C/H selector (Master)                            | ●                   | ●   | ●   | ○   | ●   | ●   | ●   |
| 4   | C/H selector (Slave)                             | ●                   | ●   | ●   | ●   | ○   | ●   | ●   |
| 5   | Low noise operation *                            | ●                   | ●   | ○   | ●   | ●   | ●   | ●   |
| 6   | Demand operation *                               | ●                   | ●   | ○   | ●   | ●   | ●   | ●   |

\* Setting No. 1, 5, 6 are the present status display only.

#### Display for malfunction/preparing/test-run

|                    |   |   |   |   |   |   |   |
|--------------------|---|---|---|---|---|---|---|
| Normal             | ● | ● | ○ | ● | ● | ● | ● |
| Malfunction        | ● | ○ | ○ | ● | ● | ● | ● |
| Preparing/Test-run | ● | ◐ | ○ | ● | ● | ● | ● |

#### Display during low noise operation

|                            |   |   |   |   |   |   |   |
|----------------------------|---|---|---|---|---|---|---|
| Normal                     | ● | ● | ○ | ● | ● | ● | ● |
| During low noise operation | ● | ● | ○ | ● | ● | ○ | ● |

H3P to H5P LED display changes depending on setting No. 2, 3, 4.

#### Display during demand operation

|                         |   |   |   |   |   |   |   |
|-------------------------|---|---|---|---|---|---|---|
| Normal                  | ● | ● | ○ | ● | ● | ● | ● |
| During demand operation | ● | ● | ○ | ● | ● | ● | ○ |

H3P to H5P LED display changes depending on setting No. 2, 3, 4.

**b. "Setting mode 2"**

Push and hold the MODE button (BS1) for 5 seconds and set to "Setting mode 2".

**<Selection of setting items>**

Push the SET button (BS2) and set the LED display to a setting item shown in the table on the right.  
↓  
Push the RETURN button (BS3) and decide the item. (The present setting condition is blinked.)

**<Selection of setting conditions>**

Push the SET button (BS2) and set to the setting condition you want.  
↓  
Push the RETURN button (BS3) and decide the condition.

Push the RETURN button (BS3) and set to the initial status of "Setting mode 2".

\* If you become unsure of how to proceed, push the MODE button (BS1) and return to setting mode 1.

(V2764)

| No. | Setting item  | Description  |
|-----|---|--|
| 0   | EMG (Emergency operation 1)   | Operates by Standard compressor only when inverter compressor malfunctions. Temporary operation until the compressor is replaced. Since the comfortability is extremely deteriorated, immediately replace the compressor.      |
| 1   | Cool/heat unified address   | Sets address for cool/heat unified operation.  |
| 2   | Low noise/demand address  | Address for low noise/demand operation   |
| 5   | Indoor unit forced fan H  | Allows forced operation of indoor unit fan while unit is stopped. (H tap)  |
| 6   | Indoor unit forced operation  | Allows forced operation of indoor unit.  |
| 8   | Te setting  | Target evaporation temperature for cooling   |
| 9   | Tc setting  | Target condensation temperature for heating  |
| 10  | Defrost changeover setting  | Changes the temperature condition for defrost and sets to quick defrost or slow defrost.   |
| 11  | Sequential operation setting  | Sets sequential operation  |
| 12  | External low noise setting / Demand setting                                   | Reception of external low noise or demand signal   |
| 13  | AIRNET address  | Set address for AIRNET.  |
| 18  | High static pressure setting  | Make this setting in the case of operating in high static pressure mode with diffuser duct mounted.  |
| 19  | Emergency operation (STD compressor operation prohibited)                     | Used to operate system only with inverter compressor when STD compressor malfunctions. This is a temporary operation extremely impairing comfortable environment. Therefore, prompt replacement of the compressor is required. |
| 20  | Additional refrigerant charge operation setting                               | Carries out additional refrigerant charge operation.   |
| 21  | Refrigerant recovery/vacuuming mode setting                                   | Sets to refrigerant collection mode.   |
| 22  | Night-time low noise setting  | Sets automatic nighttime low noise operation in a simple way. The operating time is based on "Starting set" and "Ending set".  |
| 25  | Low noise setting   | Sets low noise level when the low noise signal is input from outside.  |
| 26  | Night-time low noise control starting setting                                 | Sets starting time of nighttime low noise operation. (Nighttime low noise setting is also required.)   |
| 27  | Night-time low noise control ending setting                                   | Sets ending time of nighttime low noise operation. (Nighttime low noise setting is also required.)   |
| 28  | Power transistor check mode<br>*Check after disconnection of compressor wires | Used for trouble diagnosis of DC compressor. Since the waveform of inverter is output without wiring to the compressor, it is convenient to probe whether the trouble comes from the compressor or PC board.                   |
| 29  | Capacity precedence setting   | If the capacity control is required, the low noise control is automatically released by this setting during carrying out low noise operation and nighttime low noise operation.  |
| 30  | Demand setting 1  | Changes target value of power consumption when demand control 1 is input.  |
| 32  | Normal demand setting   | Normally enables demand control 1 without external input. (Effective to prevent a problem that circuit breaker of small capacity is shut down due to large load.   |

○ : ON ● : OFF ◐ : Blink

| No. | Setting item display  |          |          |               |            |           |               |            | Setting condition display         |                     |  |  |  |                   |  |                   |
|-----|---|----------|----------|---------------|------------|-----------|---------------|------------|-----------------------------------|---------------------|--|--|--|-------------------|--|-------------------|
|     | Setting item  | MODE H1P | TEST H2P | C/H selection |            |           | Low noise H6P | Demand H7P |                                   |                     | * Factory set                              |  |  |                   |  |                   |
|     |   |          |          | IND H3P       | Master H4P | Slave H5P |               |            |                                   |                     |  |  |  |                   |  |                   |
| 0   | EMG (emergency operation) INV compressor operation inhibited. | ○        | ●        | ●             | ●          | ●         | ●             | ●          | Normal operation                  | ○ ● ● ● ● ● ● ● ● * | Emergency operation                        | ○ ● ● ● ● ● ● ● ●                                  |  |                   |  |                   |
| 1   | Cool / Heat Unified address                                   | ○        | ●        | ●             | ●          | ●         | ●             | ○          | Address 0                         | ○ ● ● ● ● ● ● ● ● * | Binary number (6 digits)                   | 1 ○ ● ● ● ● ● ● ● ○<br>~<br>31 ○ ● ○ ○ ○ ○ ○ ○ ○ ○ |  |                   |  |                   |
| 2   | Low noise/demand address                                      | ○        | ●        | ●             | ●          | ●         | ○             | ●          | Address 0                         | ○ ● ● ● ● ● ● ● ● * | Binary number (6 digits)                   | 1 ○ ● ● ● ● ● ● ● ○<br>~<br>31 ○ ● ○ ○ ○ ○ ○ ○ ○ ○ |  |                   |  |                   |
| 5   | Indoor forced fan H   | ○        | ●        | ●             | ●          | ○         | ●             | ○          | Normal operation                  | ○ ● ● ● ● ● ● ● ● * | Indoor forced fan H                        | ○ ● ● ● ● ● ● ● ●                                  |  |                   |  |                   |
| 6   | Indoor forced operation                                       | ○        | ●        | ●             | ●          | ○         | ○             | ●          | Normal operation                  | ○ ● ● ● ● ● ● ● ● * | Indoor forced operation                    | ○ ● ● ● ● ● ● ● ●                                  |  |                   |  |                   |
| 8   | Te setting  | ○        | ●        | ●             | ○          | ●         | ●             | ●          | High                              | ○ ● ● ● ● ○ ● ● ●   | Normal (factory setting)                   | ○ ● ● ● ● ● ● ● ● *                                | Low  | ○ ● ● ● ● ● ● ● ● |  |                   |
| 9   | Tc setting  | ○        | ●        | ●             | ○          | ●         | ●             | ○          | High                              | ○ ● ● ● ● ○ ● ● ●   | Normal (factory setting)                   | ○ ● ● ● ● ● ● ● ● *                                | Low  | ○ ● ● ● ● ● ● ● ● |  |                   |
| 10  | Defrost setting   | ○        | ●        | ●             | ○          | ●         | ○             | ●          | Quick defrost                     | ○ ● ● ● ● ○ ● ● ●   | Normal (factory setting)                   | ○ ● ● ● ● ● ● ● ● *                                | Slow defrost                               | ○ ● ● ● ● ● ● ● ● |  |                   |
| 11  | Sequential operation setting                                  | ○        | ●        | ●             | ○          | ●         | ○             | ○          | OFF                               | ○ ● ● ● ● ● ● ● ●   | ON   | ○ ● ● ● ● ● ● ● ● *                                |  |                   |  |                   |
| 12  | External low noise/demand setting                             | ○        | ●        | ●             | ○          | ○         | ●             | ●          | External low noise/demand: NO     | ○ ● ● ● ● ● ● ● ● * | External low noise/demand: YES             | ○ ● ● ● ● ● ● ● ●                                  |  |                   |  |                   |
| 13  | Airnet address  | ○        | ●        | ●             | ○          | ○         | ●             | ○          | Address 0                         | ○ ● ● ● ● ● ● ● ● * | Binary number (6 digits)                   | 1 ○ ● ● ● ● ● ● ● ○<br>~<br>63 ○ ○ ○ ○ ○ ○ ○ ○ ○ ○ |  |                   |  |                   |
| 18  | High static pressure setting                                  | ○        | ●        | ○             | ●          | ●         | ○             | ●          | High static pressure setting: OFF | ○ ● ● ● ● ● ● ● ● * | High static pressure setting: ON           | ○ ● ● ● ● ● ● ● ●                                  |  |                   |  |                   |
| 19  | Emergency operation (STD compressor is inhibited to operate.) | ○        | ●        | ○             | ●          | ●         | ○             | ○          | OFF                               | ○ ● ● ● ● ● ● ● ● * | STD 1, 2 operation: Inhibited              | ○ ● ● ● ● ● ● ● ●                                  | STD 2 operation: Inhibited                 | ○ ● ● ● ● ● ● ● ● |  |                   |
| 20  | Additional refrigerant charge operation setting               | ○        | ●        | ○             | ●          | ○         | ●             | ●          | Refrigerant charging: OFF         | ○ ● ● ● ● ● ● ● ● * | Refrigerant charging: ON                   | ○ ● ● ● ● ● ● ● ●                                  |  |                   |  |                   |
| 21  | Refrigerant recovery / vacuuming mode setting                 | ○        | ●        | ○             | ●          | ○         | ●             | ○          | Refrigerant recovery: OFF         | ○ ● ● ● ● ● ● ● ● * | Refrigerant recovery: ON                   | ○ ● ● ● ● ● ● ● ●                                  |  |                   |  |                   |
| 22  | Night-time low noise setting                                  | ○        | ●        | ○             | ●          | ○         | ○             | ●          | OFF                               | ○ ● ● ● ● ● ● ● ● * | Level 1 (outdoor fan with 6 step or lower) | ○ ● ● ● ● ● ● ● ●                                  | Level 2 (outdoor fan with 5 step or lower) | ○ ● ● ● ● ● ● ● ● | Level 3 (outdoor fan with 4 step or lower) | ○ ● ● ● ● ● ● ● ● |



○ : ON ● : OFF ◐ : Blink

| No. | Setting item display                         |          |          |               |            |           |               |            | Setting condition display  |               |
|-----|--|----------|----------|---------------|------------|-----------|---------------|------------|--|---------------|
|     | Setting item                                 | MODE H1P | TEST H2P | C/H selection |            |           | Low noise H6P | Demand H7P |  |               |
|     |  |          |          | IND H3P       | Master H4P | Slave H5P |               |            |  |               |
|     |  |          |          |               |            |           |               |            |  | * Factory set |
| 25  | Low noise setting                            | ○        | ●        | ○             | ○          | ●         | ●             | ○          | Level 1 (outdoor fan with 6 step or lower) ○ ● ● ● ● ● ● ○<br>Level 2 (outdoor fan with 5 step or lower) ○ ● ● ● ● ● ○ ● *<br>Level 3 (outdoor fan with 4 step or lower) * ○ ● ● ● ● ○ ● ● |               |
| 26  | Night-time low noise operation start setting | ○        | ●        | ○             | ○          | ●         | ○             | ●          | About 20:00 ○ ● ● ● ● ● ● ○<br>About 22:00 (factory setting) ○ ● ● ● ● ● ○ ● *<br>About 24:00 ○ ● ● ● ● ○ ● ●  |               |
| 27  | Night-time low noise operation end setting   | ○        | ●        | ○             | ○          | ●         | ○             | ○          | About 6:00 ○ ● ● ● ● ● ● ○<br>About 7:00 ○ ● ● ● ● ● ○ ●<br>About 8:00 (factory setting) ○ ● ● ● ● ○ ● ● *   |               |
| 28  | Power transistor check mode                  | ○        | ●        | ○             | ○          | ○         | ●             | ●          | OFF ○ ● ● ● ● ● ● ○ *<br>ON ○ ● ● ● ● ● ○ ●  |               |
| 29  | Capacity precedence setting                  | ○        | ●        | ○             | ○          | ○         | ●             | ○          | OFF ○ ● ● ● ● ● ● ○ *<br>ON ○ ● ● ● ● ● ○ ●  |               |
| 30  | Demand setting 1                             | ○        | ●        | ○             | ○          | ○         | ○             | ●          | 60 % demand ○ ● ● ● ● ● ● ○<br>70 % demand ○ ● ● ● ● ● ○ ● *<br>80 % demand ○ ● ● ● ● ○ ● ●  |               |
| 32  | Normal demand setting                        | ○        | ○        | ●             | ●          | ●         | ●             | ●          | OFF ○ ● ● ● ● ● ● ○ *<br>ON ○ ● ● ● ● ● ○ ●  |               |

○ : ON ● : OFF ◐ : Blink

**c. Monitor mode**

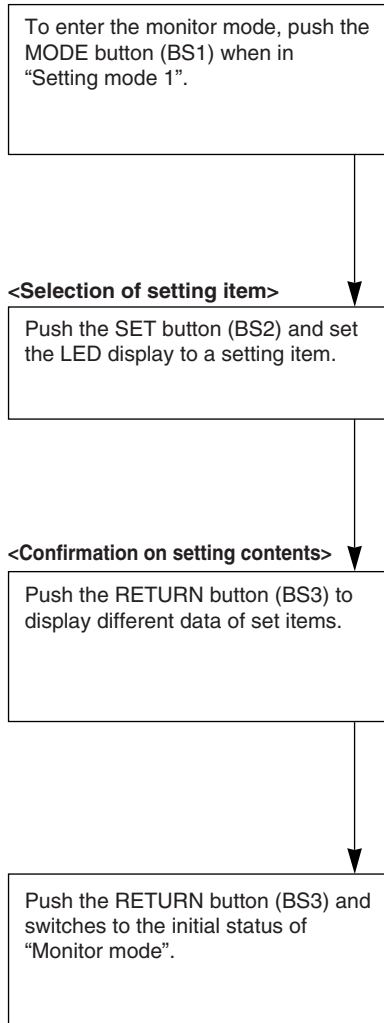

\* Push the MODE button (BS1) and returns to "Setting mode 1".

(V2765)

| No. | Setting item   | LED display |     |     |     |     |     |     | Data display                                  |
|-----|--|-------------|-----|-----|-----|-----|-----|-----|---|
|     |  | H1P         | H2P | H3P | H4P | H5P | H6P | H7P |   |
| 0   | Number of units for sequential starting, and others            | ◐           | ●   | ●   | ●   | ●   | ●   | ●   | See below                                     |
| 1   | C/H unified address  | ◐           | ●   | ●   | ●   | ●   | ●   | ○   | Lower 6 digits                                |
| 2   | Low noise/demand address                                       | ◐           | ●   | ●   | ●   | ●   | ○   | ●   |   |
| 3   | Not used   | ◐           | ●   | ●   | ●   | ●   | ○   | ○   |   |
| 4   | Airnet address   | ◐           | ●   | ●   | ●   | ○   | ●   | ●   |   |
| 5   | Number of connected indoor units                               | ◐           | ●   | ●   | ●   | ○   | ●   | ○   |   |
| 6   | Number of connected BS units                                   | ◐           | ●   | ●   | ●   | ○   | ○   | ●   |   |
| 7   | Number of connected zone units (excluding outdoor and BS unit) | ◐           | ●   | ●   | ●   | ○   | ○   | ○   |   |
| 8   | Number of outdoor units  | ◐           | ●   | ●   | ○   | ●   | ●   | ●   |   |
| 9   | Number of connected BS units                                   | ◐           | ●   | ●   | ○   | ●   | ●   | ○   | Lower 4 digits: upper                         |
| 10  | Number of connected BS units                                   | ◐           | ●   | ●   | ○   | ●   | ○   | ●   | Lower 4 digits: lower                         |
| 11  | Number of zone units (excluding outdoor and BS unit)           | ◐           | ●   | ●   | ○   | ●   | ○   | ○   | Lower 6 digits                                |
| 12  | Number of terminal blocks                                      | ◐           | ●   | ●   | ○   | ○   | ●   | ●   | Lower 4 digits: upper                         |
| 13  | Number of terminal blocks                                      | ◐           | ●   | ●   | ○   | ○   | ●   | ○   | Lower 4 digits: lower                         |
| 14  | Contents of malfunction (the latest)                           | ○           | ●   | ●   | ○   | ○   | ○   | ●   | Malfunction code table<br>Refer page 118,119. |
| 15  | Contents of malfunction (1 cycle before)                       | ○           | ●   | ●   | ○   | ○   | ○   | ○   |   |
| 16  | Contents of malfunction (2 cycle before)                       | ○           | ●   | ○   | ●   | ●   | ●   | ●   |   |
| 20  | Contents of retry (the latest)                                 | ○           | ●   | ○   | ●   | ○   | ●   | ●   |   |
| 21  | Contents of retry (1 cycle before)                             | ○           | ●   | ○   | ●   | ○   | ●   | ○   |   |
| 22  | Contents of retry (2 cycle before)                             | ○           | ●   | ○   | ●   | ○   | ○   | ●   |   |

**Setting item 0 Display contents of "Number of units for sequential start, and others"**

|   |         |   |   |   |   |   |   |   |
|---|---------|---|---|---|---|---|---|---|
| Number of units for sequential start    | 1 unit  | ◐ | ● | ● | ● | ● | ● | ● |
|   | 2 units | ◐ | ● | ◐ | ● | ● | ● | ● |
|   | 3 units | ◐ | ● | ○ | ● | ● | ● | ● |
| EMG operation /backup operation setting | ON      | ◐ | ● | ● | ○ | ● | ● | ● |
|   | OFF     | ◐ | ● | ● | ● | ● | ● | ● |
| Defrost select setting                  | Short   | ◐ | ● | ● | ● | ○ | ● | ● |
|   | Medium  | ◐ | ● | ● | ● | ◐ | ● | ● |
|   | Long    | ◐ | ● | ● | ● | ● | ● | ● |
| Te setting                              | H       | ◐ | ● | ● | ● | ● | ○ | ● |
|   | M       | ◐ | ● | ● | ● | ● | ◐ | ● |
|   | L       | ◐ | ● | ● | ● | ● | ● | ● |
| Tc setting                              | H       | ◐ | ● | ● | ● | ● | ● | ○ |
|   | M       | ◐ | ● | ● | ● | ● | ● | ◐ |
|   | L       | ◐ | ● | ● | ● | ● | ● | ● |

Push the SET button and match with the LEDs No. 1 - 15, push the RETURN button, and enter the data for each setting.

★ Data such as addresses and number of units is expressed as binary numbers; the two ways of expressing are as follows:

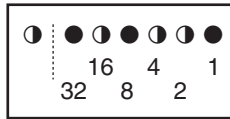

The No. 1 cool/heat unified address is expressed as a binary number consisting of the lower 6 digits. (0 - 63)

In ① the address is 010110 (binary number), which translates to  $16 + 4 + 2 = 22$  (base 10 number). In other words, the address is 22.

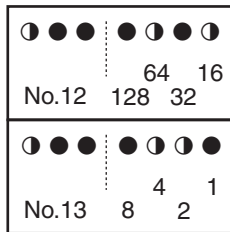

The number of terminal blocks for No. 12 and 13 is expressed as an 8-digit binary number, which is the combination of four upper, and four lower digits for No. 12 and 13 respectively. (0 - 128)

In ② the address for No. 12 is 0101, the address for No. 13 is 0110, and the combination of the two is 01010110 (binary number), which translates to  $64 + 16 + 4 + 2 = 86$  (base 10 number). In other words, the number of terminal block is 86.

★ See the preceding page for a list of data, etc. for No. 0 - 22.

### 3.2.2 Cool / Heat Mode Switching

There are the following 4 cool/heat switching modes.

- ① Set cool/heat separately for each outdoor unit system by indoor unit remote controller.
- ② Set cool/heat separately for each outdoor unit system by cool/heat selector.
- ③ Set cool/heat for more than one outdoor unit system simultaneously in accordance with unified master outdoor unit by indoor unit remote controller.
- ④ Set cool/heat for more than one outdoor unit system simultaneously in accordance with unified master outdoor unit by cool/heat switching remote controller.

#### ① Set Cool / Heat Separately for Each Outdoor Unit System by Indoor Unit Remote Controller

- ◆ It does not matter whether or not there is outdoor - outdoor unit wiring.
- ◆ Set outdoor unit PC board DS1-1 to IN (factory set).
- ◆ Set cool/heat switching to IND (individual) for "Setting mode 1" (factory set).
- ◆ Set the master unit (= indoor unit having the right to select the cooling/heating operation mode).

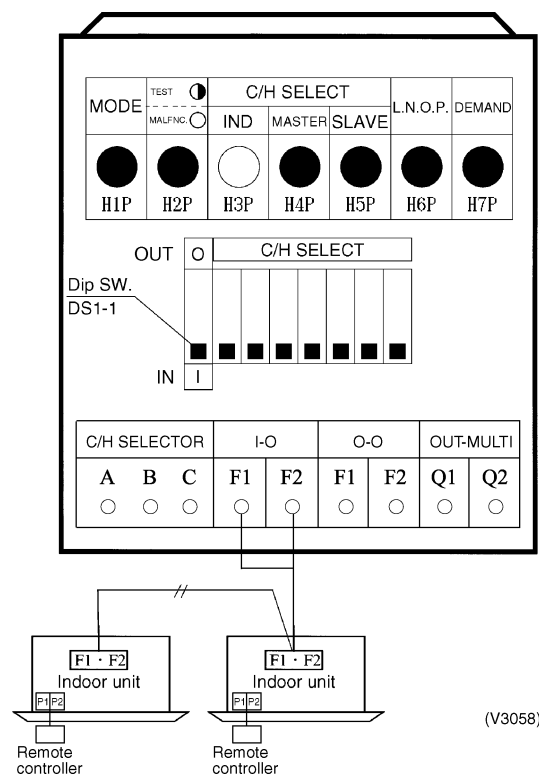

<Set the master unit (= indoor unit having the right to select the cooling/heating operation mode).>

#### In the case of wired remote controllers

- After the check operation, "CHANGEOVER UNDER CONTROL" is flashing in all connected remote controllers.
- Select an indoor unit to be used as the master unit in accordance with the request from the customer. (It is recommended to select an indoor unit which will be used most often as the master unit.)
- Press the operation mode selector button in the remote controller of the indoor unit selected as the master unit.
- In that remote controller, "CHANGEOVER UNDER CONTROL" disappears. That remote controller will control changeover of the cooling/heating operation mode.
- In other remote controllers, "CHANGEOVER UNDER CONTROL" lights.

For the details, refer to the installation manual supplied together with the indoor unit.

#### In the case of wireless remote controllers

- After the check operation, the timer lamp is flashing in all connected indoor units.
- Select an indoor unit to be used as the master unit in accordance with the request from the customer. (It is recommended to select an indoor unit which will be used most often as the master unit.)
- Press the operation selector mode button in the remote controller of the indoor unit selected as the master unit. A "peep" sound is emitted, and the timer lamp turns off in all indoor units.
- That indoor unit will control changeover of the cooling/heating operation mode.

② Set Cool / Heat Separately for Each Outdoor Unit System by Cool / Heat Selector

- ◆ It does not matter whether or not there is outdoor - outdoor unit wiring.
- ◆ Set outdoor unit PC board DS1-1 to OUT (factory set).
- ◆ Set cool/heat switching to IND (individual) for "Setting mode 1" (factory set).

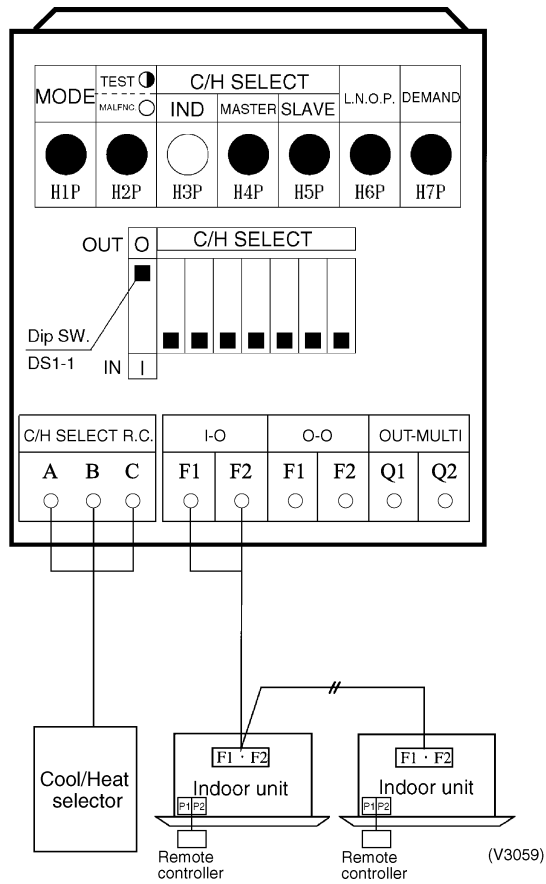

③ Set Cool / Heat for More Than One Outdoor Unit System Simultaneously in Accordance with Unified Master Outdoor Unit by Indoor Unit Remote Controller

- ◆ Install the external control adapter for outdoor unit on either the outdoor-outdoor, indoor-outdoor, or transmission line.
- ◆ Set outdoor unit PC board DS1-1 to "Indoor" (factory set).
- ◆ In setting mode 1, set the outdoor unit you want to give cool/heat selection permission to as the group master, and set the other outdoor units as group slave units.
- ◆ Set the external control adapter for outdoor unit SS1 to BOTH (factory set) or C/H, and SS2 to OFF (factory set).

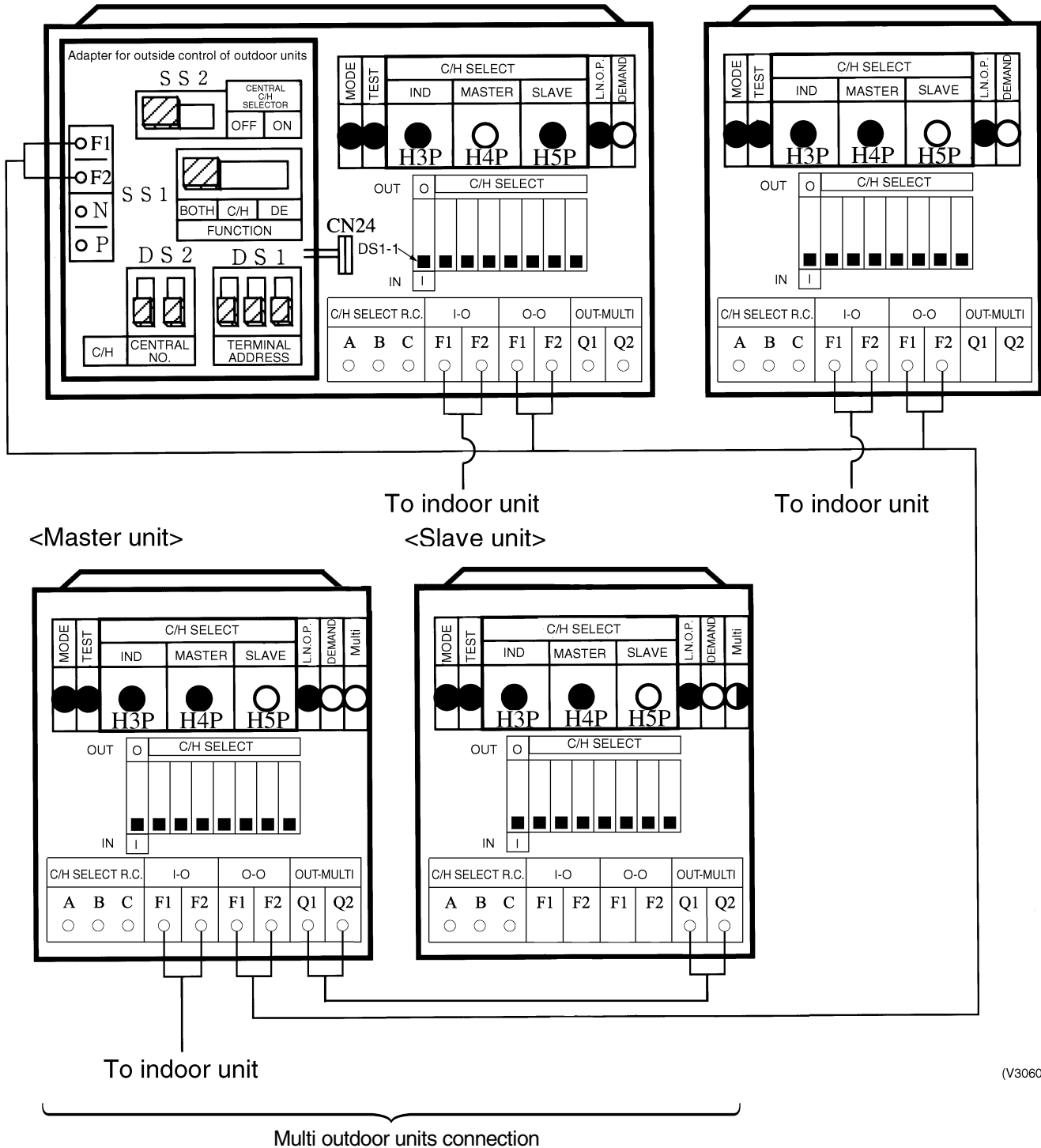

(V3060)

④ Set Cool / Heat for More Than One Outdoor Unit System Simultaneously in Accordance with Unified Master Outdoor Unit by Cool/Heat Switching Remote Controller

- ◆ Install cool/heat select remote controller on the group master outdoor unit.
- ◆ Install the external control adaptor for outdoor unit on either the outdoor-outdoor, indoor-outdoor, or transmission line.
- ◆ Set group master outdoor unit PC board DS1-1 to "Outdoor" (factory set).
- ◆ In setting mode 1, set the outdoor unit you want to give cool/heat selection permission to as the group master, and set the other outdoor units as group slave units.
- ◆ Set the external control adaptor for outdoor unit SS1 to BOTH (factory set) or C/H, and SS2 to OFF (factory set).

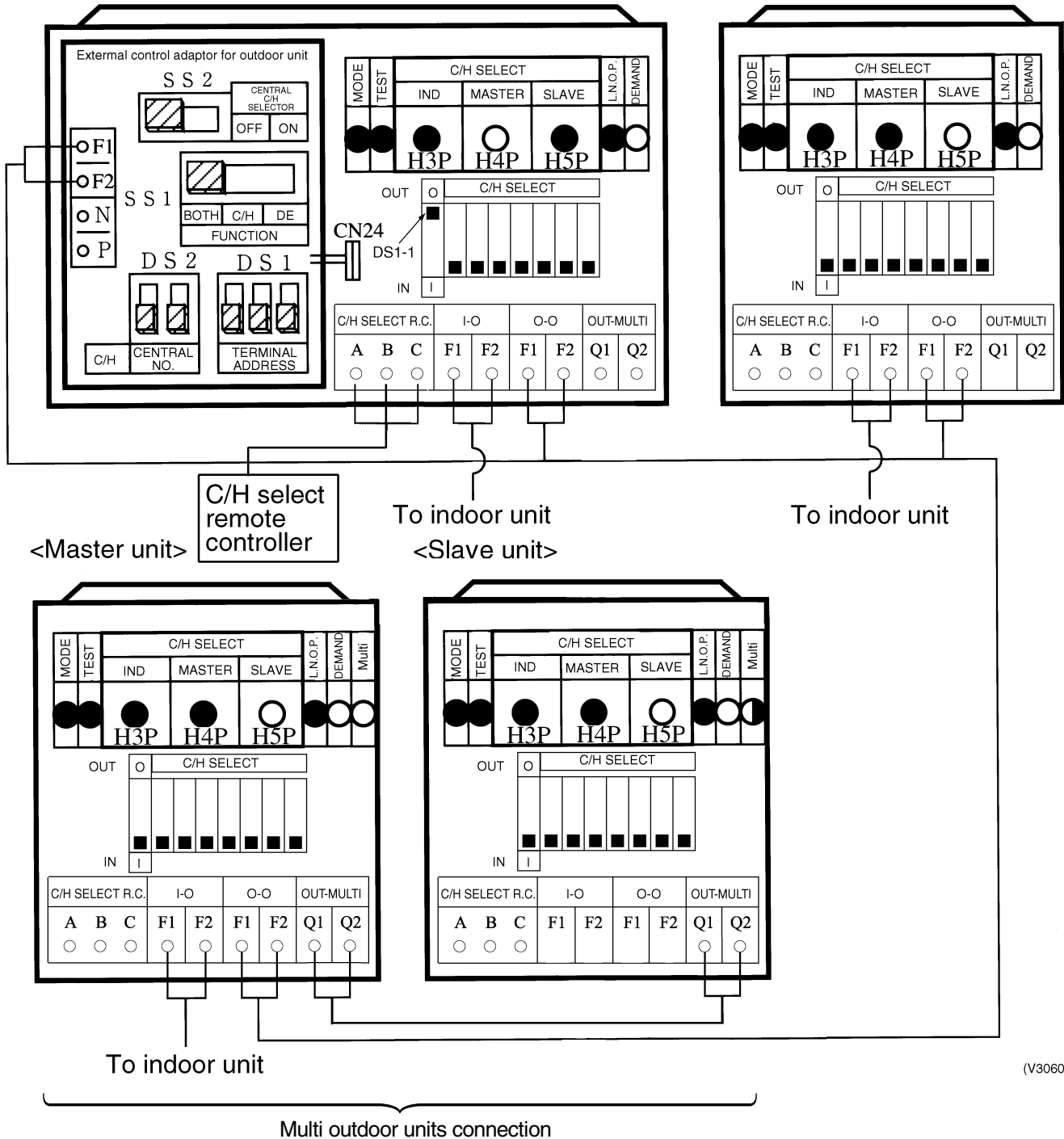

(V3060)

**Supplementation on ③ and ④.**

When switching cool/heat for each adapter PC board with the use of more than one adapter PC board, set the address of the adapter PC board DS1 and DS2 so that it matches the unified cool/heat address of outdoor unit PC board.

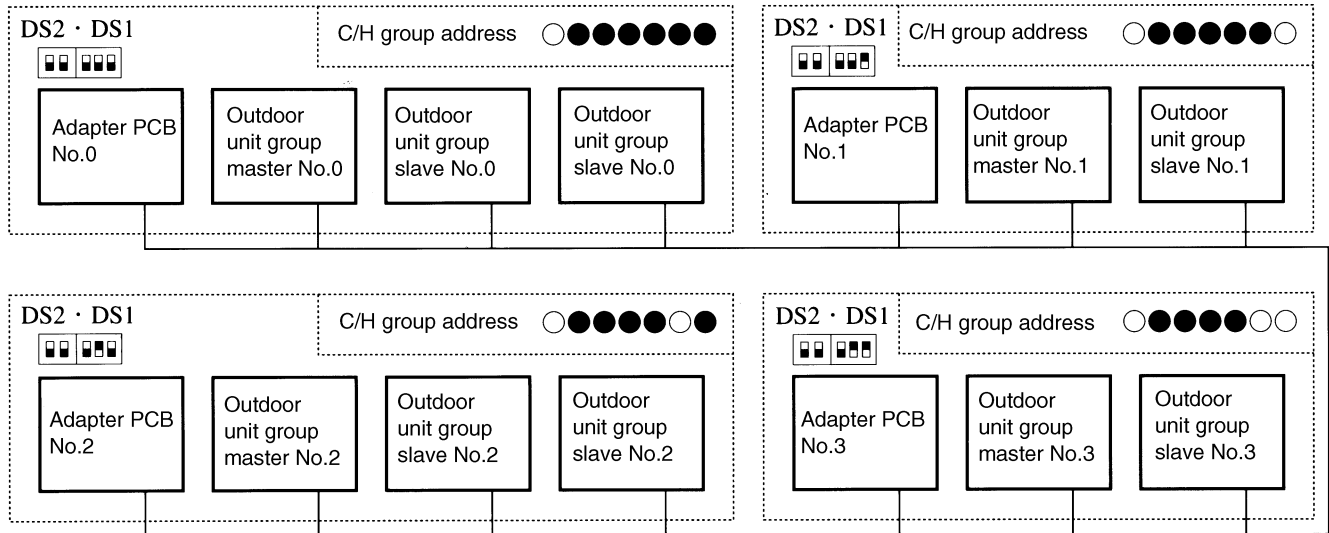

(V2723)

**Address setting for ③ and ④ (Set lower 5 digits with binary number.) [No.0 to No.31]**

| Address No. | Outdoor unit PCB LED<br>Set with setting mode 2 |                  | Adapter PCB |     |     |     |   |    |
|-------------|---|------------------|-------------|-----|-----|-----|---|----|
|             | DS2   | DS1              | DS2         | DS1 | DS1 | DS1 |   |    |
| No 0        | ○ ●   | ● ● ● ● ● ●<br>0 |             |     |     |     |   | 0  |
| No 1        | ○ ●   | ● ● ● ● ● ○      |             |     |     |     |   | 1  |
| No 2        | ○ ●   | ● ● ● ○ ● ●      |             |     |     |     |   | 2  |
| No 3        | ○ ●   | ● ● ● ○ ○        |             |     |     |     |   | 3  |
| No 4        | ○ ●   | ● ● ○ ● ●        |             |     |     |     |   | 4  |
| }           | }   | }                | }           | }   | }   | }   | } | }  |
| No 30       | ○ ●   | ○ ○ ○ ○ ●<br>30  |             |     |     |     |   | 30 |
| No 31       | ○ ●   | ○ ○ ○ ○ ○<br>31  |             |     |     |     |   | 31 |

○ ON ● OFF Upper position (ON) lower position (OFF)

(The shaded part shows knob)

(V2724)



### 3.2.3 Setting of Low Noise Operation and Demand Operation

---

#### Setting of Low Noise Operation

By connecting the external contact input to the low noise input of the outdoor unit external control adapter (optional), you can lower operating noise by 2-3 dB.

##### **A. When the low noise operation is carried out by external instructions (with the use of the external control adapter for outdoor unit)**

1. Set "External low noise / Demand YES/NO setting" to "External low noise / Demand YES". (Set by Setting Mode 2)
2. Set "External low noise level setting" on the outdoor unit PC board, as the need arises. (Lower noise operation can be carried out by "Mode 2" than by "Mode 1", and by "Mode 3" than by "Mode 2".)
3. Set "Capacity precedence setting" on the outdoor unit PC board, as the need arises. (If set to "ON", when air conditioning load gets higher, the low noise instructions are neglected to switch to normal operation.) (Set by Setting Mode 2)

##### **B. When the low noise operation is carried out automatically at night (The external control adapter for outdoor unit is not required)**

1. Set "Night-time low noise setting" on the outdoor unit PC board. (Set by Setting Mode 2) (Lower noise operation can be carried out by "Mode 2" than by "Mode 1", and by "Mode 3" than by "Mode 2".)
2. Set "Night-time low noise start setting" on the outdoor unit PC board, as the need arises. (Set by Setting Mode 2) (Since the time is presumed in accordance with the outdoor temperature, the starting time is a target only.)
3. Set "Night-time low noise end setting" on the outdoor unit PC board, as the need arises. (Set by Setting Mode 2) (Since the time is presumed in accordance with the outdoor temperature, the ending time is a target only.)
4. Set "Capacity precedence setting" on the outdoor unit PC board, as the need arises. (Set by Setting Mode 2) (If set to "ON", when air conditioning load gets higher, the status is switched to normal operation even at night.)

**Image of operation in the case of A**

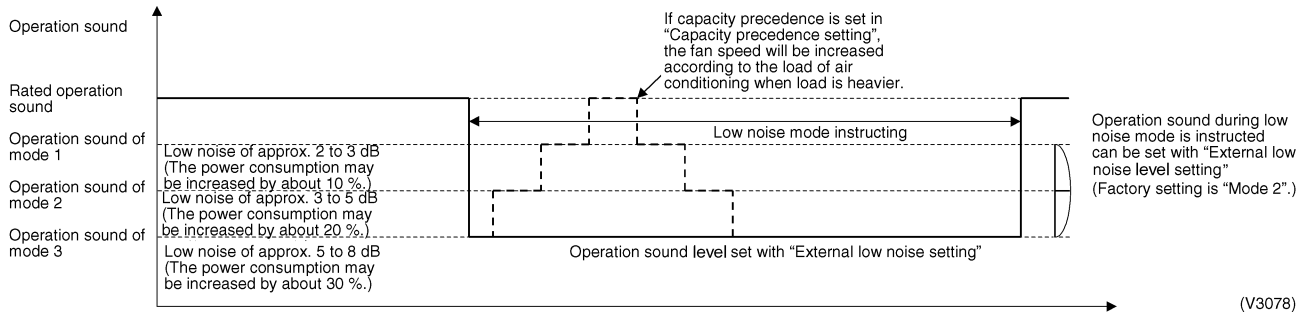

**Image of operation in the case of B**

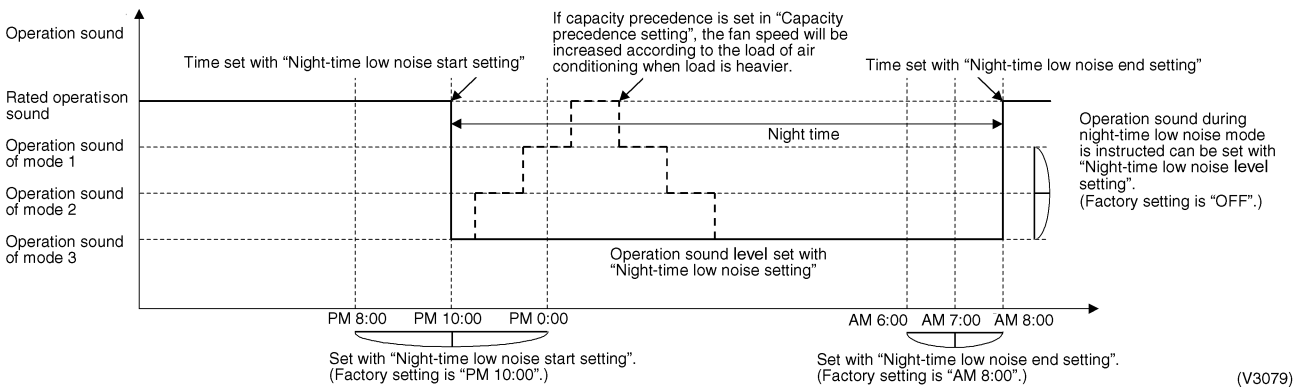

**Image of operation in the case of A and B**

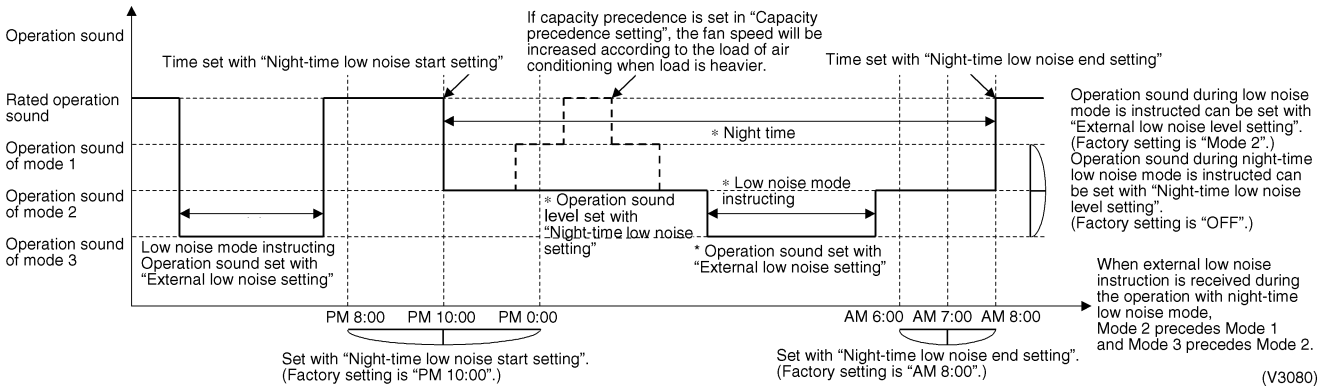

---

**Setting of Demand Operation**

By connecting the external contact input to the demand input of the outdoor unit external control adapter (optional), the power consumption of unit operation can be saved suppressing the compressor operating condition.

**A. When the demand operation is carried out by external instructions (with the use of the external control adapter for outdoor unit).**

1. Set the "External low noise/Demand YES/NO setting" switch on the outdoor unit PCB to the "External low noise/Demand YES".  
(Set by Setting Mode 2)
2. Set the "Demand 1 level setting" on the outdoor unit PCB, as the need arises.  
(During the demand level 1 instruction, the power consumption can be saved to 80 %, 70 % or 60 % of the rated value respectively.)

**B. When the normal demand operation is carried out. (Use of the external control adapter for outdoor unit is not required.)**

1. Set the "Normal demand setting" on the outdoor unit PCB to ON.
2. Set the "Demand 1 setting" on the outdoor unit PCB, as the need arises.  
(During the normal demand setting operation, the power consumption can be saved to 80 %, 70 % or 60 % of the rated value respectively.)

**Image of operation in the case of A**

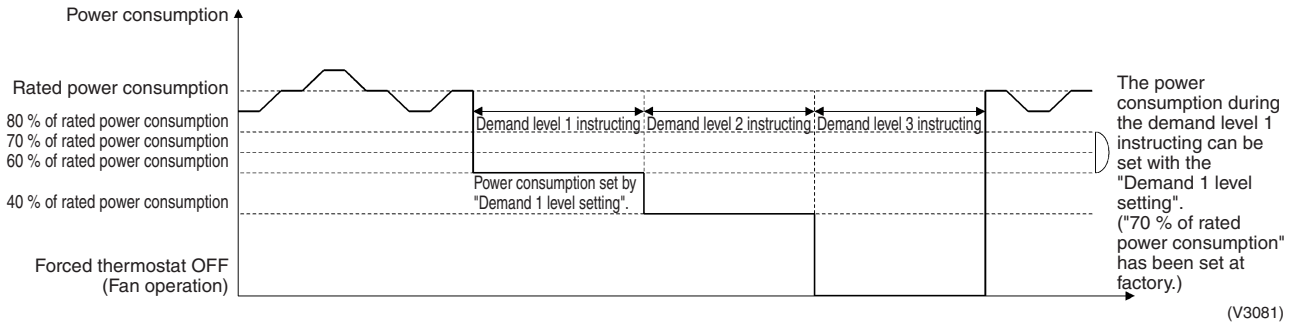

**Image of operation in the case of B**

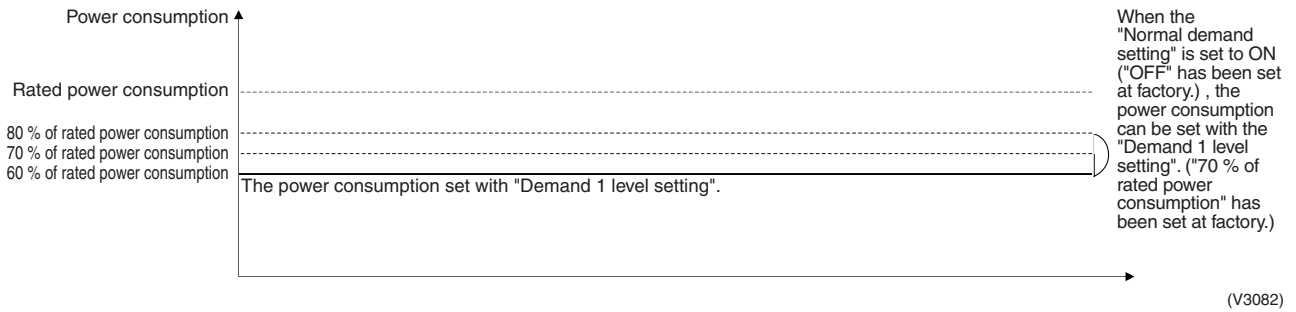

**Image of operation in the case of A and B**

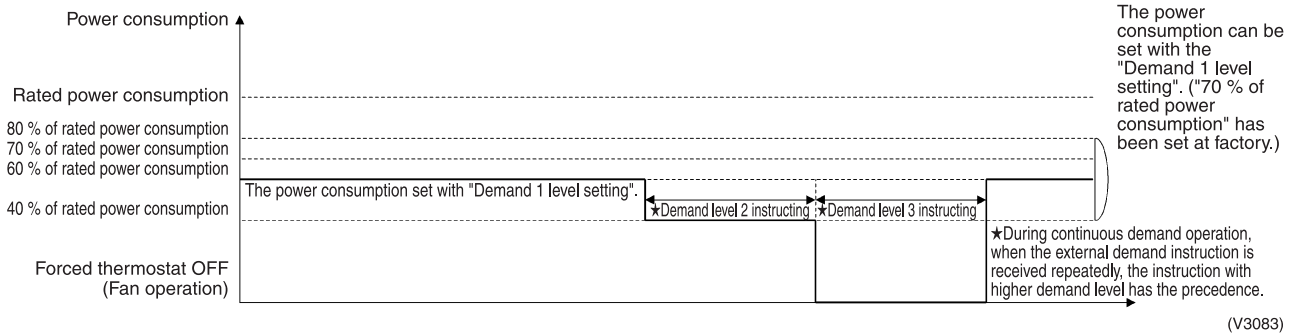

---

**Detailed Setting Procedure of Low Noise Operation and Demand Control****1. Setting mode 1 (H1P off)**

- ① In setting mode 2, push the BS1 (MODE button) one time. → Setting mode 2 is entered and H1P lights.  
During the setting mode 1 is displayed, “In low noise operation” and “In demand control” are displayed.

**2. Setting mode 2 (H1P on)**

- ① In setting 1, push and hold the BS1 (MODE button) for more than 5 seconds. → Setting mode 2 is entered and H1P lights.
- ② Push the BS2 (SET button) several times and match the LED display with the Setting No. you want.
- ③ Push the BS3 (RETURN button) one time, and the present setting content is displayed.  
→ Push the BS2 (SET button) several times and match the LED display with the setting content (as shown below) you want.
- ④ Push the BS3 (RETURN button) two times. → Returns to ①.
- ⑤ Push the BS1 (MODE button) one time. → Returns to the setting mode 1 and turns H1P off.

| Setting No. | Setting contents                    | ① Setting No. indication        |     |     |     |     |     |     | ② Setting No. indication  |     |     |     |     |     |     | Setting contents                                  | ③ Setting contents indication (Initial setting) |                                  |                                  |                                  |                                  |                                  |                                  |                                  |                                  |                       |
|-------------|-------------------------------------|---------------------------------|-----|-----|-----|-----|-----|-----|---|-----|-----|-----|-----|-----|-----|---|---|----------------------------------|----------------------------------|----------------------------------|----------------------------------|----------------------------------|----------------------------------|----------------------------------|----------------------------------|-----------------------|
|             |                                     | H1P                             | H2P | H3P | H4P | H5P | H6P | H7P | H1P   | H2P | H3P | H4P | H5P | H6P | H7P |   | H1P   | H2P                              | H3P                              | H4P                              | H5P                              | H6P                              | H7P                              |                                  |                                  |                       |
|             |                                     | Setting mode indication section |     |     |     |     |     |     | Setting No. indication section  |     |     |     |     |     |     |   | Set contents indication section                 |                                  |                                  |                                  |                                  |                                  |                                  |                                  |                                  |                       |
| 12          | External low noise / Demand setting |                                 |     |     |     |     |     |     | <input type="radio"/> H1P <input checked="" type="radio"/> H2P <input checked="" type="radio"/> H3P <input type="radio"/> H4P <input type="radio"/> H5P <input checked="" type="radio"/> H6P <input checked="" type="radio"/> H7P                       |     |     |     |     |     |     | NO (Factory setting)                              | <input type="radio"/>                           | <input checked="" type="radio"/> | <input checked="" type="radio"/> | <input checked="" type="radio"/> | <input checked="" type="radio"/> | <input checked="" type="radio"/> | <input checked="" type="radio"/> | <input checked="" type="radio"/> | <input checked="" type="radio"/> | <input type="radio"/> |
|             |                                     |                                 |     |     |     |     |     |     |   |     |     |     |     |     |     | YES   | <input type="radio"/>                           | <input checked="" type="radio"/> | <input checked="" type="radio"/> | <input checked="" type="radio"/> | <input checked="" type="radio"/> | <input type="radio"/>            | <input checked="" type="radio"/> | <input checked="" type="radio"/> |                                  |                       |
| 22          | Night-time low noise setting        |                                 |     |     |     |     |     |     | <input type="radio"/> H1P <input checked="" type="radio"/> H2P <input type="radio"/> H3P <input checked="" type="radio"/> H4P <input checked="" type="radio"/> H5P <input checked="" type="radio"/> H6P <input checked="" type="radio"/> H7P            |     |     |     |     |     |     | OFF (Factory setting)                             | <input type="radio"/>                           | <input checked="" type="radio"/> | <input checked="" type="radio"/> | <input checked="" type="radio"/> | <input checked="" type="radio"/> | <input checked="" type="radio"/> | <input checked="" type="radio"/> | <input checked="" type="radio"/> | <input checked="" type="radio"/> |                       |
|             |                                     |                                 |     |     |     |     |     |     |   |     |     |     |     |     |     | Mode 1  | <input type="radio"/>                           | <input checked="" type="radio"/> | <input checked="" type="radio"/> | <input checked="" type="radio"/> | <input checked="" type="radio"/> | <input checked="" type="radio"/> | <input checked="" type="radio"/> | <input type="radio"/>            |                                  |                       |
|             |                                     |                                 |     |     |     |     |     |     |   |     |     |     |     |     |     | Mode 2  | <input type="radio"/>                           | <input checked="" type="radio"/> | <input checked="" type="radio"/> | <input checked="" type="radio"/> | <input checked="" type="radio"/> | <input checked="" type="radio"/> | <input checked="" type="radio"/> | <input type="radio"/>            |                                  |                       |
|             |                                     |                                 |     |     |     |     |     |     |   |     |     |     |     |     |     | Mode 3  | <input type="radio"/>                           | <input checked="" type="radio"/> | <input checked="" type="radio"/> | <input checked="" type="radio"/> | <input checked="" type="radio"/> | <input checked="" type="radio"/> | <input type="radio"/>            | <input type="radio"/>            |                                  |                       |
| 25          | External low noise setting          |                                 |     |     |     |     |     |     | <input type="radio"/> H1P <input checked="" type="radio"/> H2P <input type="radio"/> H3P <input type="radio"/> H4P <input checked="" type="radio"/> H5P <input checked="" type="radio"/> H6P <input type="radio"/> H7P                                  |     |     |     |     |     |     | Mode 1  | <input type="radio"/>                           | <input checked="" type="radio"/> | <input checked="" type="radio"/> | <input checked="" type="radio"/> | <input checked="" type="radio"/> | <input checked="" type="radio"/> | <input checked="" type="radio"/> | <input checked="" type="radio"/> |                                  |                       |
|             |                                     |                                 |     |     |     |     |     |     |   |     |     |     |     |     |     | Mode 2 (Factory setting)                          | <input type="radio"/>                           | <input checked="" type="radio"/> | <input checked="" type="radio"/> | <input checked="" type="radio"/> | <input checked="" type="radio"/> | <input type="radio"/>            | <input checked="" type="radio"/> |                                  |                                  |                       |
|             |                                     |                                 |     |     |     |     |     |     |   |     |     |     |     |     |     | Mode 3  | <input type="radio"/>                           | <input checked="" type="radio"/> | <input checked="" type="radio"/> | <input checked="" type="radio"/> | <input type="radio"/>            | <input checked="" type="radio"/> | <input checked="" type="radio"/> |                                  |                                  |                       |
| 26          | Night-time low noise start setting  |                                 |     |     |     |     |     |     | <input type="radio"/> H1P <input checked="" type="radio"/> H2P <input type="radio"/> H3P <input type="radio"/> H4P <input checked="" type="radio"/> H5P <input type="radio"/> H6P <input checked="" type="radio"/> H7P                                  |     |     |     |     |     |     | PM 8:00   | <input type="radio"/>                           | <input checked="" type="radio"/> | <input checked="" type="radio"/> | <input checked="" type="radio"/> | <input checked="" type="radio"/> | <input checked="" type="radio"/> | <input type="radio"/>            |                                  |                                  |                       |
|             |                                     |                                 |     |     |     |     |     |     |   |     |     |     |     |     |     | PM 10:00 (Factory setting)                        | <input type="radio"/>                           | <input checked="" type="radio"/> | <input checked="" type="radio"/> | <input checked="" type="radio"/> | <input checked="" type="radio"/> | <input type="radio"/>            | <input checked="" type="radio"/> |                                  |                                  |                       |
|             |                                     |                                 |     |     |     |     |     |     |   |     |     |     |     |     |     | PM 0:00   | <input type="radio"/>                           | <input checked="" type="radio"/> | <input checked="" type="radio"/> | <input checked="" type="radio"/> | <input type="radio"/>            | <input checked="" type="radio"/> | <input checked="" type="radio"/> |                                  |                                  |                       |
| 27          | Night-time low noise end setting    |                                 |     |     |     |     |     |     | <input type="radio"/> H1P <input checked="" type="radio"/> H2P <input type="radio"/> H3P <input type="radio"/> H4P <input checked="" type="radio"/> H5P <input type="radio"/> H6P <input type="radio"/> H7P   |     |     |     |     |     |     | AM 6:00   | <input type="radio"/>                           | <input checked="" type="radio"/> | <input checked="" type="radio"/> | <input checked="" type="radio"/> | <input checked="" type="radio"/> | <input checked="" type="radio"/> | <input type="radio"/>            |                                  |                                  |                       |
|             |                                     |                                 |     |     |     |     |     |     |   |     |     |     |     |     |     | AM 7:00   | <input type="radio"/>                           | <input checked="" type="radio"/> | <input checked="" type="radio"/> | <input checked="" type="radio"/> | <input checked="" type="radio"/> | <input type="radio"/>            | <input checked="" type="radio"/> |                                  |                                  |                       |
|             |                                     |                                 |     |     |     |     |     |     |   |     |     |     |     |     |     | AM 8:00 (Factory setting)                         | <input type="radio"/>                           | <input checked="" type="radio"/> | <input checked="" type="radio"/> | <input type="radio"/>            | <input checked="" type="radio"/> | <input checked="" type="radio"/> | <input checked="" type="radio"/> |                                  |                                  |                       |
| 29          | Capacity precedence setting         |                                 |     |     |     |     |     |     | <input type="radio"/> H1P <input checked="" type="radio"/> H2P <input type="radio"/> H3P <input type="radio"/> H4P <input type="radio"/> H5P <input checked="" type="radio"/> H6P <input type="radio"/> H7P   |     |     |     |     |     |     | Low noise precedence (Factory setting)            | <input type="radio"/>                           | <input checked="" type="radio"/> | <input checked="" type="radio"/> | <input checked="" type="radio"/> | <input checked="" type="radio"/> | <input checked="" type="radio"/> | <input type="radio"/>            |                                  |                                  |                       |
|             |                                     |                                 |     |     |     |     |     |     |   |     |     |     |     |     |     | Capacity precedence                               | <input type="radio"/>                           | <input checked="" type="radio"/> | <input checked="" type="radio"/> | <input checked="" type="radio"/> | <input checked="" type="radio"/> | <input type="radio"/>            | <input checked="" type="radio"/> |                                  |                                  |                       |
| 30          | Demand setting 1                    |                                 |     |     |     |     |     |     | <input type="radio"/> H1P <input checked="" type="radio"/> H2P <input type="radio"/> H3P <input type="radio"/> H4P <input type="radio"/> H5P <input type="radio"/> H6P <input checked="" type="radio"/> H7P   |     |     |     |     |     |     | 60 % of rated power consumption                   | <input type="radio"/>                           | <input checked="" type="radio"/> | <input checked="" type="radio"/> | <input checked="" type="radio"/> | <input checked="" type="radio"/> | <input checked="" type="radio"/> | <input type="radio"/>            |                                  |                                  |                       |
|             |                                     |                                 |     |     |     |     |     |     |   |     |     |     |     |     |     | 70 % of rated power consumption (Factory setting) | <input type="radio"/>                           | <input checked="" type="radio"/> | <input checked="" type="radio"/> | <input checked="" type="radio"/> | <input checked="" type="radio"/> | <input type="radio"/>            | <input checked="" type="radio"/> |                                  |                                  |                       |
|             |                                     |                                 |     |     |     |     |     |     |   |     |     |     |     |     |     | 80 % of rated power consumption                   | <input type="radio"/>                           | <input checked="" type="radio"/> | <input checked="" type="radio"/> | <input checked="" type="radio"/> | <input type="radio"/>            | <input checked="" type="radio"/> | <input checked="" type="radio"/> |                                  |                                  |                       |
| 32          | Normal demand setting               |                                 |     |     |     |     |     |     | <input type="radio"/> H1P <input checked="" type="radio"/> H2P <input checked="" type="radio"/> H3P <input checked="" type="radio"/> H4P <input checked="" type="radio"/> H5P <input checked="" type="radio"/> H6P <input checked="" type="radio"/> H7P |     |     |     |     |     |     | OFF (Factory setting)                             | <input type="radio"/>                           | <input checked="" type="radio"/> | <input checked="" type="radio"/> | <input checked="" type="radio"/> | <input checked="" type="radio"/> | <input checked="" type="radio"/> | <input type="radio"/>            |                                  |                                  |                       |
|             |                                     |                                 |     |     |     |     |     |     |   |     |     |     |     |     |     | ON  | <input type="radio"/>                           | <input checked="" type="radio"/> | <input checked="" type="radio"/> | <input checked="" type="radio"/> | <input checked="" type="radio"/> | <input type="radio"/>            | <input checked="" type="radio"/> |                                  |                                  |                       |

### 3.2.4 Setting of Refrigerant Additional Charging Operation

When additional refrigerant is not charged all with outdoor unit in stop mode, operate the outdoor unit and charge the liquid refrigerant from the service port of liquid stop valve. The additional charging operation is activated by pushbutton switch on the outdoor unit PC board.

**[Additional refrigerant charge total flow]**

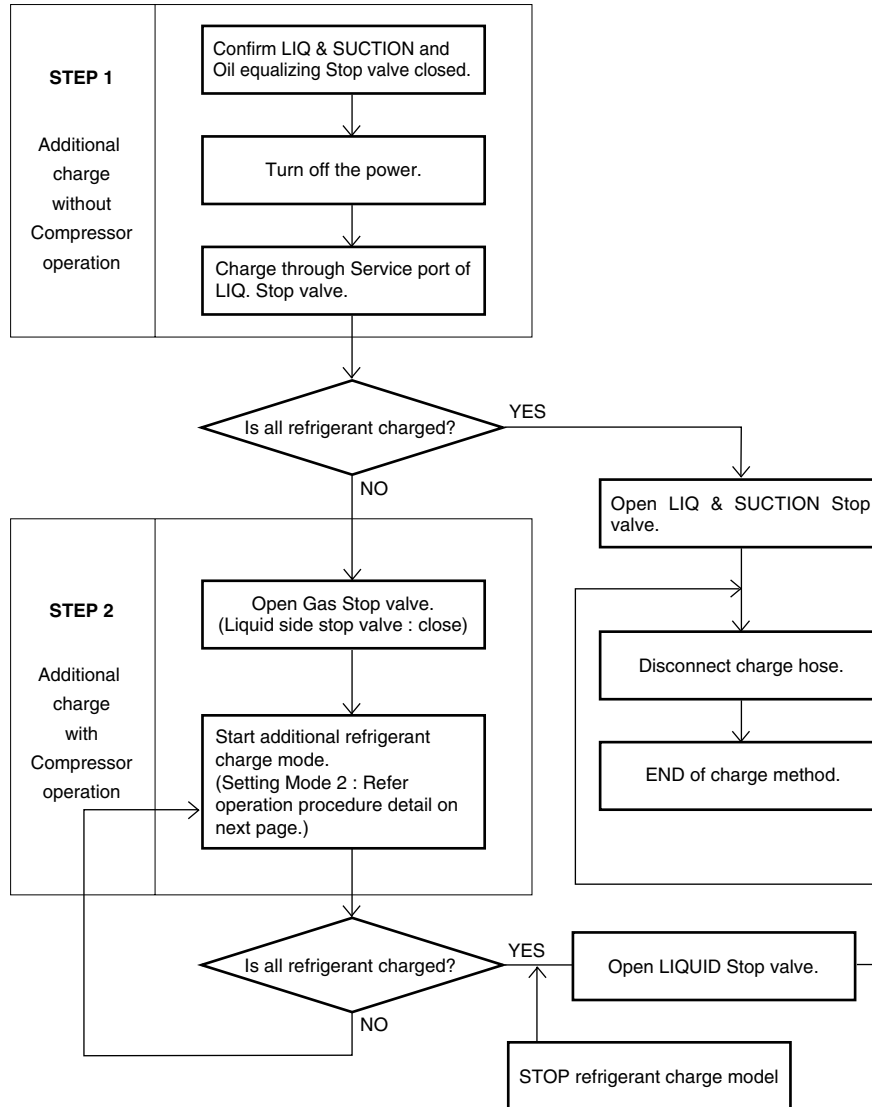

(V2892)

**[Operation procedure detail]**

- ① After turning the respective power supply switch of indoor and outdoor units off and charging the refrigerant, turn on the power of indoor and outdoor units.  
Do not fail to turn the power off and charge the refrigerant with outdoor unit in stop mode before adding the refrigerant following this procedure, otherwise resulting in trouble.
- ② Fully open the stop valve on the gas side and oil equalizing valve for multi outdoor connection, and do not fail to fully close the stop valve on the liquid side. (If the stop valve on the liquid side is open, the refrigerant cannot be charged.)
- ③ In **Setting mode 2** (H1P : ON) with outdoor unit in stop mode, Set “Additional refrigerant charging operation” switch to ON to start the operation. (H2P turns to display TEST OPERATION (blinks), and “TEST OPERATION” and “UNDER CENTRALIZED CONTROL” are displayed on the remote controller.)
- ④ When the refrigerant is charged up to the specified amount, press the RETURN button (BS3) to stop charging.  
The charging operation is automatically stopped after operating for a maximum of about 30 minutes.  
If the charging is not complete within 30 minutes, set the Additional refrigerant charging operation again to start charging. When the charging immediately stops even by restarting, the refrigerant is charged excessively. The refrigerant cannot be charged any more.
- ⑤ **Do not fail to fully open the stop valve on the liquid side** as soon as disconnecting the refrigerant charging hose.  
**(The piping may be burst due to the liquid sealing.)**

**[Operation state]**

- Compressor frequency : 210Hz
- Y1S, Y2S, Y3S Solenoid valve : Open
- Outdoor unit fan : High pressure control
- Indoor unit expansion valve (All unit) : 1024 pulse
- Indoor unit fan : H tap

### 3.2.5 Setting of Refrigerant Recovery Mode

When carrying out the refrigerant collection on site, fully open the respective expansion valve of indoor and outdoor units.

All indoor and outdoor unit's operation are prohibited.

**[Operation procedure]**

- ① In **setting mode 2** with units in stop mode, set “Refrigerant Recovery / Vacuuming mode” to ON. The respective expansion valve of indoor and outdoor units are fully opened. (H2P turns to display “TEST OPERATION” (blinks), “TEST OPERATION” and “UNDER CENTRALIZED CONTROL” are displayed on the remote controller, and the all indoor and outdoor unit operation are prohibited.  
After setting, do not cancel “Setting Mode 2” until completion of refrigerant recovery operation.
- ② Collect the refrigerant using a refrigerant recovery unit. (See the instruction attached to the refrigerant recovery unit for more detail.)
- ③ Press Mode button “BS1” once and reset “Setting Mode 2”.



### 3.2.6 Setting of Vacuuming Mode

In order to perform vacuuming operation at site, fully open the expansion valves of indoor and outdoor units and turn on some solenoid valves.

**[Operating procedure]**

- ① With **Setting Mode 2** while the unit stops, set (B) Refrigerant recovery / Vacuuming mode to ON. The expansion valves of indoor and outdoor units fully open and some of solenoid valves open.  
(H2P blinks to indicate the test operation, and the remote controller displays "Test Operation" and "Under Centralized control", thus prohibiting operation.)  
After setting, do not cancel "Setting Mode 2" until completion of Vacuuming operation.
- ② Use the vacuum pump to perform vacuuming operation.
- ③ Press Mode button "BS1" once and reset "Setting Mode 2".

### 3.2.7 Check Operation

To prevent any trouble in the period of installation at site, the system is provided with a test operation mode enabling check for incorrect wiring, stop valve left in closed, coming out (or misplacing with suction pipe thermistor) of discharge pipe thermistor and judgment of piping length, refrigerant overcharging, and learning for the minimum opening degree of motorized valve.

**CHECK OPERATION FUNCTION**

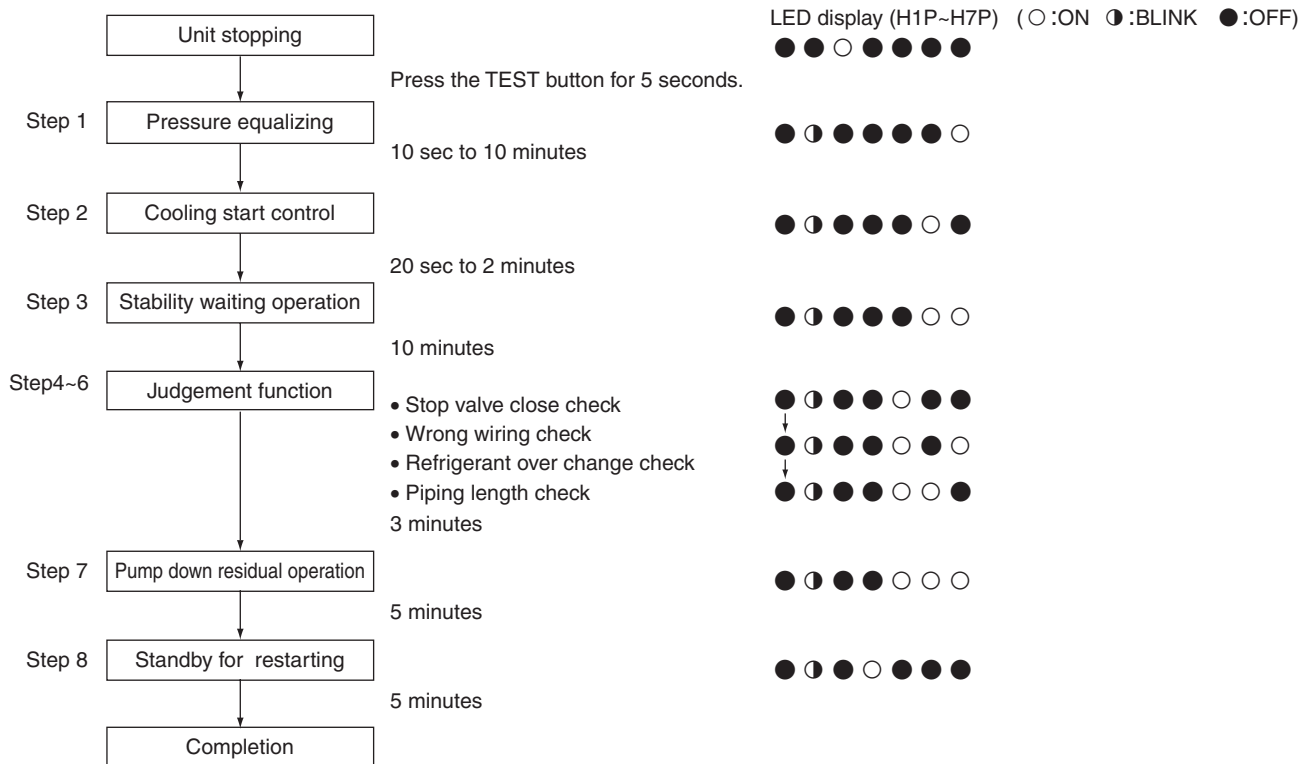

### 3.2.8 Power Transistor Check Operation

When the inverter system malfunctions (malfunction of inverter, INV compressor), to locate where the malfunction occurs, switching to the power transistor check mode of inverter in the service mode setting enables not to judge the position detection signal malfunction but to output waveform only during inverter operation. (The waveform can be checked by disconnecting the wiring of compressor.)

After the completion of checks, return the system to the previous mode and wait for 30 seconds or more until the discharge of capacitor is completed. Then, conduct a subsequent work.

**Notes:**

Be sure to disconnect the compressor wiring when conducting the check operation mentioned above.

When the output voltage is approx. 100~200 V (10 Hz) and the voltage balance between phases U-V, V-W, W-U is within  $\pm 5\%$ , the inverter PCB is normal.



Refer the detail power transistor check to page 215.



# Part 6

## Troubleshooting

|  |     |
|--|-----|
| 1. Troubleshooting by Remote Controller .....  | 108 |
| 1.1 The INSPECTION / TEST Button.....  | 108 |
| 1.2 Self-diagnosis by Wired Remote Controller .....  | 109 |
| 1.3 Self-diagnosis by Wireless Remote Controller .....   | 110 |
| 1.4 Operation of The Remote Controller's Inspection /<br>Test Operation Button .....                   | 112 |
| 1.5 Remote Controller Service Mode .....   | 113 |
| 1.6 Remote Controller Self-Diagnosis Function .....  | 115 |
| 2. Troubleshooting by Indication on the Remote Controller .....  | 120 |
| 2.1 "R0" Indoor Unit: Error of External Protection Device .....  | 120 |
| 2.2 "R1" Indoor Unit: PC Board Defect.....   | 121 |
| 2.3 "R3" Indoor Unit: Malfunction of Drain Level Control System (S1L) .....                            | 122 |
| 2.4 "R5" Indoor Unit: Fan Motor (M1F) Lock, Overload.....  | 124 |
| 2.5 "R7" Indoor Unit: Malfunction of Swing Flap Motor (MA) .....                                       | 125 |
| 2.6 "R9" Indoor Unit: Malfunction of Moving Part of<br>Electronic Expansion Valve (20E) .....          | 127 |
| 2.7 "R11" Indoor Unit: Drain Level above Limit.....  | 129 |
| 2.8 "R13" Indoor Unit: Malfunction of Capacity Determination Device .....                              | 130 |
| 2.9 "C1" Indoor Unit: Malfunction of Thermistor (R2T) for Heat Exchanger ....                          | 131 |
| 2.10 "C5" Indoor Unit: Malfunction of Thermistor (R3T) for Gas Pipes.....                              | 132 |
| 2.11 "C9" Indoor Unit: Malfunction of Thermistor (R1T) for Suction Air.....                            | 133 |
| 2.12 "C13" Indoor Unit: Malfunction of Thermostat Sensor in<br>Remote Controller .....                 | 134 |
| 2.13 "E1" Outdoor Unit: PC Board Defect .....  | 135 |
| 2.14 "E3" Outdoor Unit: Actuation of High Pressure Switch .....  | 136 |
| 2.15 "E4" Outdoor Unit: Actuation of Low Pressure Sensor .....   | 137 |
| 2.16 "E5" Compressor Motor Lock .....  | 139 |
| 2.17 "E6" Compressor Motor Overcurrent/Lock .....  | 141 |
| 2.18 "E7" Malfunction of Outdoor Unit Fan Motor .....  | 142 |
| 2.19 "E9" Outdoor Unit: Malfunction of Moving Part of<br>Electronic Expansion Valve (Y1E, Y2E).....    | 144 |
| 2.20 "F3" Outdoor Unit: Abnormal Discharge Pipe Temperature .....                                      | 146 |
| 2.21 "F6" Refrigerant Overcharged .....  | 147 |
| 2.22 "H1" Abnormal Outdoor Fan Motor Signal .....  | 148 |
| 2.23 "H9" Outdoor Unit: Malfunction of Thermistor (R1T) for Outdoor Air.....                           | 150 |
| 2.24 "J2" Current Sensor Malfunction.....  | 151 |
| 2.25 "J3" Outdoor Unit: Malfunction of Discharge<br>Pipe Thermistor (R31~33T).....                     | 152 |
| 2.26 "J5" Outdoor Unit: Malfunction of Thermistor (R2T) for Suction Pipe .....                         | 153 |
| 2.27 "J6" Outdoor Unit: Malfunction of Thermistor (R4T) for<br>Outdoor Unit Heat Exchanger Deicer..... | 154 |

|      |   |     |
|------|---|-----|
| 2.28 | “J7” Malfunction of Receiver Outlet Liquid Pipe Thermistor (R6T) .....  | 155 |
| 2.29 | “JB” Malfunction of Oil Equalizing Pipe Thermistor (R7T).....   | 156 |
| 2.30 | “JS” Malfunction of Sub-Cooling Gas Pipe Thermistor (R5T) .....   | 157 |
| 2.31 | “JR” Outdoor Unit: Malfunction of Discharge Pipe Pressure Sensor.....   | 158 |
| 2.32 | “JC” Outdoor Unit: Malfunction of Suction Pipe Pressure Sensor .....  | 160 |
| 2.33 | “L4” Outdoor Unit: Malfunction of Inverter Radiating Fin Temperature Rise.....                                | 161 |
| 2.34 | “L5” Outdoor Unit: Inverter Compressor Abnormal .....   | 162 |
| 2.35 | “LB” Outdoor Unit: Inverter Current Abnormal.....   | 163 |
| 2.36 | “L3” Outdoor Unit: Inverter Start up Error.....   | 165 |
| 2.37 | “LL” Outdoor Unit: Malfunction of Transmission Between Inverter and Control PC Board .....                    | 166 |
| 2.38 | “PI” Outdoor Unit: Inverter Over-Ripple Protection .....  | 168 |
| 2.39 | “P4” Outdoor Unit: Malfunction of Inverter Radiating Fin Temperature Rise Sensor .....                        | 170 |
| 2.40 | “PJ” Outdoor Unit: Faulty Field Setting after Replacing Main PC Board or Faulty Combination of PC Board ..... | 171 |
| 2.41 | “UG” Outdoor Unit: Low Pressure Drop Due to Refrigerant Shortage or Electronic Expansion Valve Failure.....   | 172 |
| 2.42 | “U1” Outdoor Unit: Reverse Phase, Open Phase .....  | 174 |
| 2.43 | “U2” Outdoor Unit: Power Supply Insufficient or Instantaneous Failure ....                                    | 175 |
| 2.44 | “U3” Outdoor Unit: Check Operation not executed.....  | 177 |
| 2.45 | “U4” Malfunction of Transmission Between Indoor Units and Outdoor Units .....                                 | 178 |
| 2.46 | “U5” Indoor Unit: Malfunction of Transmission Between Remote Controller and Indoor Unit.....                  | 180 |
| 2.47 | “U7” Indoor Unit: Malfunction of Transmission Between Outdoor Units ....                                      | 181 |
| 2.48 | “UB” Indoor Unit: Malfunction of Transmission Between Main and Sub Remote Controllers .....                   | 183 |
| 2.49 | “UG” Indoor Unit: Malfunction of Transmission Between Indoor Units and Outdoor Units in the Same System ..... | 184 |
| 2.50 | “UR” Improper Combination of Indoor Units and Outdoor Units/Indoor Units and Remote Controller.....           | 186 |
| 2.51 | “UL” Address Duplication of Central Remote Controller.....  | 188 |
| 2.52 | “UE” Malfunction of Transmission Between Centralized Controller and Indoor Unit.....                          | 189 |
| 2.53 | “UF” System is not Set yet.....   | 191 |
| 2.54 | “UH” Malfunction of System, Refrigerant System Address Undefined.....   | 192 |
| 3.   | Troubleshooting (OP: Central Remote Controller) .....   | 194 |
| 3.1  | “M1” PC Board Defect .....  | 194 |
| 3.2  | “MB” Malfunction of Transmission Between Optional Controllers for Centralized Control .....                   | 195 |
| 3.3  | “MR” Improper Combination of Optional Controllers for Centralized Control .....                               | 197 |
| 3.4  | “ML” Address Duplication, Improper Setting .....  | 199 |

---

|  |     |
|--|-----|
| 4. Troubleshooting (OP: Schedule Timer).....   | 200 |
| 4.1 “UE” Malfunction of Transmission Between Central Remote Controller<br>and Indoor Unit.....     | 200 |
| 4.2 “77” PC Board Defect .....   | 202 |
| 4.3 “78” Malfunction of Transmission Between Optional Controllers<br>for Centralized Control ..... | 203 |
| 4.4 “79” Improper Combination of Optional Controllers<br>for Centralized Control .....             | 205 |
| 4.5 “7C” Address Duplication, Improper Setting .....   | 207 |
| 5. Troubleshooting (OP: Unified ON/OFF Controller) .....   | 208 |
| 5.1 Operation Lamp Blinks .....  | 208 |
| 5.2 Display “Under Centralized Control” Blinks (Repeats Single Blink) .....                        | 210 |
| 5.3 Display “Under Centralized Control” Blinks (Repeats Double Blink) .....                        | 213 |

# 1. Troubleshooting by Remote Controller

## 1.1 The INSPECTION / TEST Button

The following modes can be selected by using the [Inspection/Test Operation] button on the remote control.

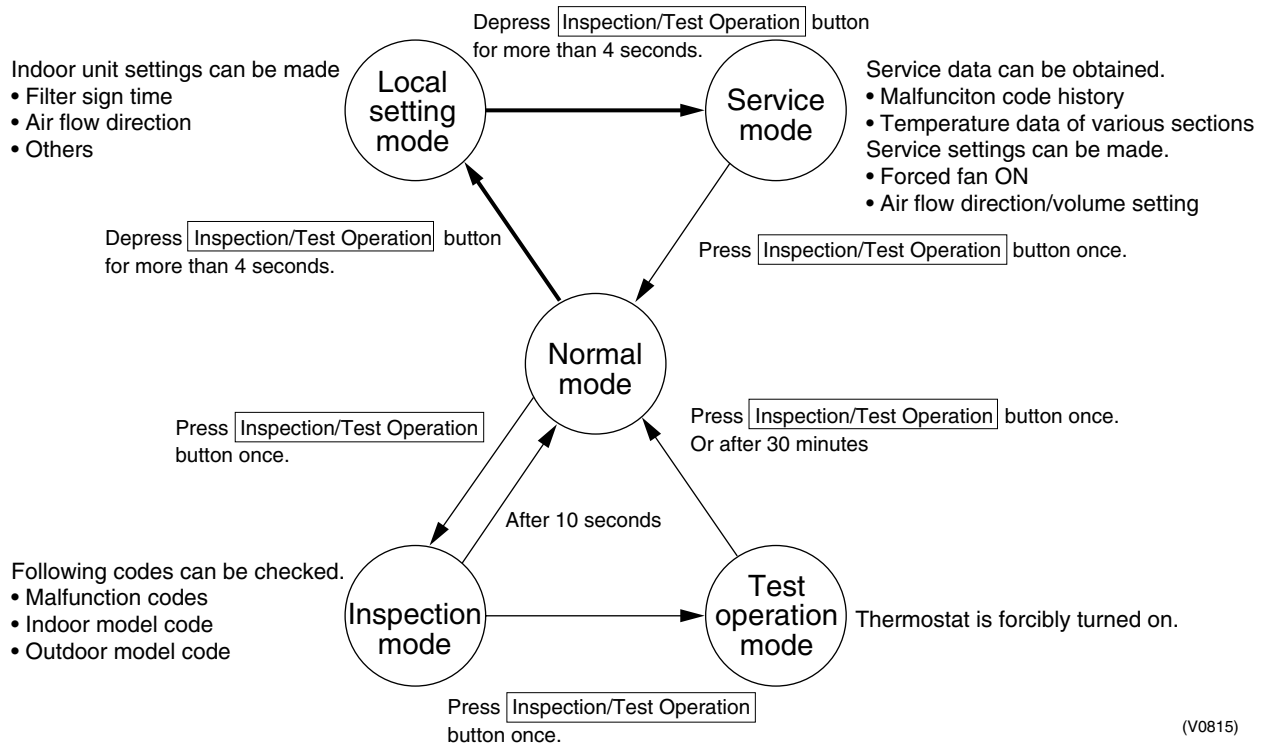

(V0815)

## 1.2 Self-diagnosis by Wired Remote Controller

### Explanation

If operation stops due to malfunction, the remote controller's operation LED blinks, and malfunction code is displayed. (Even if stop operation is carried out, malfunction contents are displayed when the inspection mode is entered.) The malfunction code enables you to tell what kind of malfunction caused operation to stop. See page 116 for malfunction code and malfunction contents.

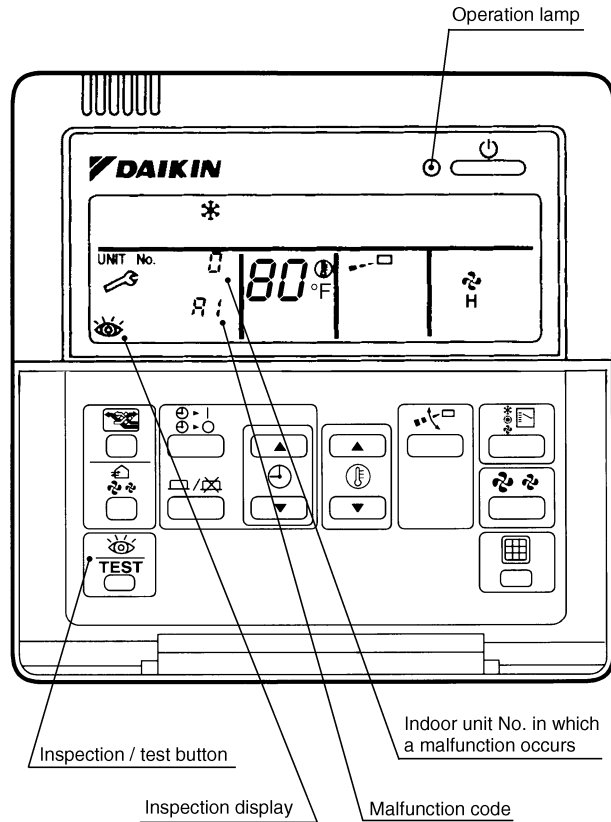

(S1155)



# 1.3 Self-diagnosis by Wireless Remote Controller

## In the Case of BRC7C ~ Type

If equipment stops due to a malfunction, the operation indicating LED on the light reception section flashes.

The malfunction code can be determined by following the procedure described below. (The malfunction code is displayed when an operation error has occurred. In normal condition, the malfunction code of the last problem is displayed.)

1. Press the INSPECTION/TEST button to select "Inspection."  
The equipment enters the inspection mode. The "Unit" indication lights and the Unit No. display shows flashing "0" indication.
2. Set the Unit No.  
Press the UP or DOWN button and change the Unit No. display until the buzzer (\*1) is generated from the indoor unit.  
\*1 Number of beeps  
**3 short beeps** : Conduct all of the following operations.  
**1 short beep** : Conduct steps 3 and 4.  
Continue the operation in step 4 until a buzzer remains ON. The continuous buzzer indicates that the malfunction code is confirmed.  
**Continuous beep** : No abnormality.
3. Press the MODE selector button.  
The left "0" (upper digit) indication of the malfunction code flashes.
4. Malfunction code upper digit diagnosis  
Press the UP or DOWN button and change the malfunction code upper digit until the malfunction code matching buzzer (\*2) is generated.

■ The upper digit of the code changes as shown below when the UP and DOWN buttons are pressed.

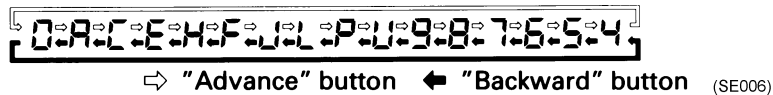

- \*2 Number of beeps  
**Continuous beep** : Both upper and lower digits matched. (Malfunction code confirmed)  
**2 short beeps** : Upper digit matched.  
**1 short beep** : Lower digit matched.

5. Press the MODE selector button.  
The right "0" (lower digit) indication of the malfunction code flashes.
6. Malfunction code lower digit diagnosis  
Press the UP or DOWN button and change the malfunction code lower digit until the continuous malfunction code matching buzzer (\*2) is generated.

- The lower digit of the code changes as shown below when the UP and DOWN buttons are pressed.

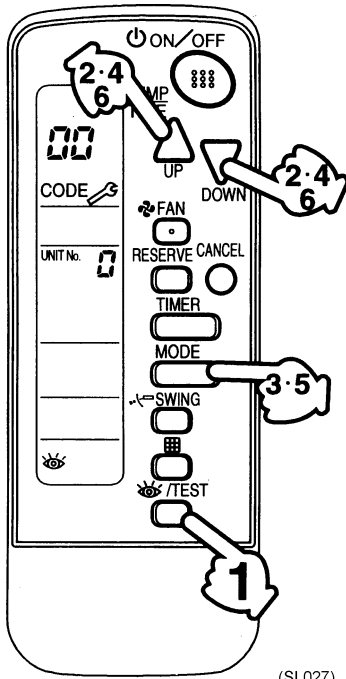

(SL027)

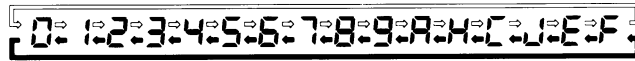

⇒ "Advance" button    ⇐ "Backward" button (SE007)

Normal status  
 Enters inspection mode from normal status when the INSPECTION/TEST button is pressed.

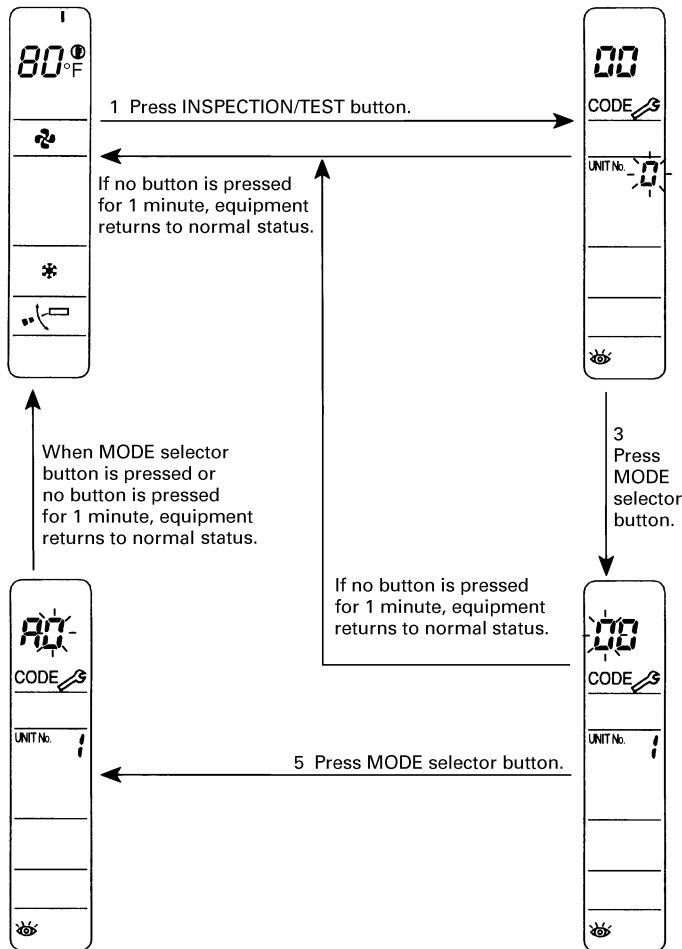

(SF008)

# 1.4 Operation of The Remote Controller's Inspection / Test Operation Button

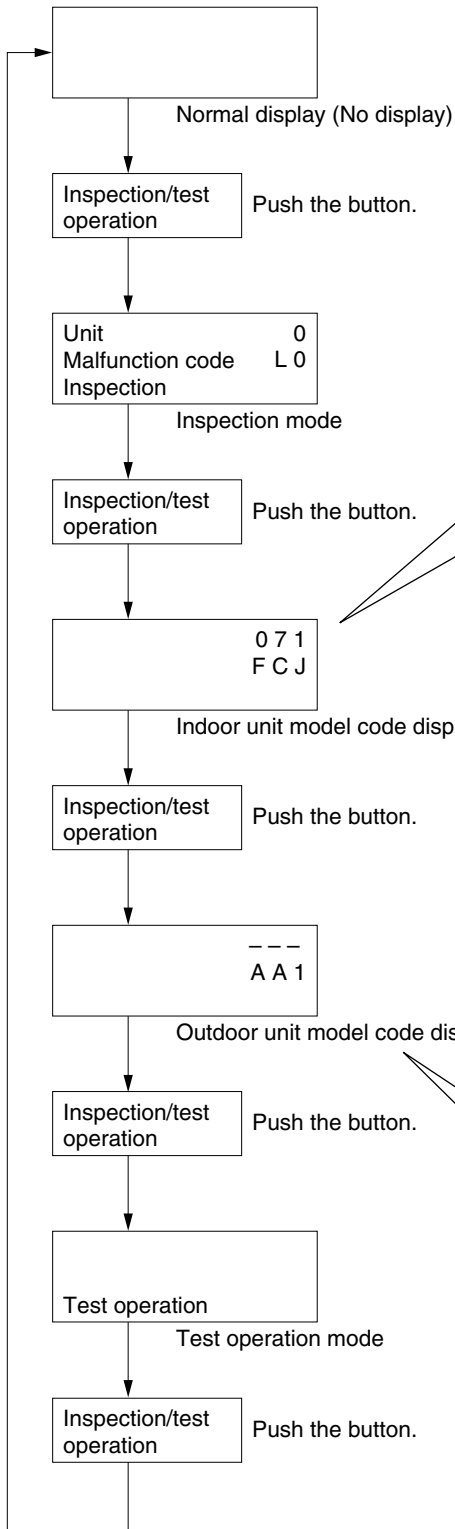

Unit 0  
Malfunction code L 0  
Inspection

Malfunction code blinks when a malfunction occurs.

0 7 1... Capacity code  
F... Indoor unit system code  
C... Indoor unit type code  
J... Progression code

Example of capacity code display

| Example model | Display |
|---------------|---------|
| FXAQ09        | 028     |
| FXSQ24        | 071     |

Indoor unit system code

| Display | Product classification | System classification |
|---------|------------------------|-----------------------|
| 1       | VRV system             | (VAV indoor unit)     |
| 2       | VRV system             | Outdoor air intake    |
| F       | VRV system             | Standard indoor unit  |

Indoor unit type code

| Display | Type                          | Model |
|---------|-------------------------------|-------|
| A       | Wall mounted                  | FXAQ  |
| F       | Multi flow                    | FXFQ  |
| H       | Ceiling suspended             | FXHQ  |
| J       | Built-in                      | FXSQ  |
| L       | Floor standing                | FXLQ  |
| P       | Concealed ceiling duct        | FXMQ  |
| L       | Concealed floor standing type | FXNQ  |
| 6       | Multi flow 600x600            | FXZQ  |
| 3       | Slim Ceiling mounted duct     | FXDQ  |

Outdoor model code

| Display | Type              | Model  |
|---------|-------------------|--------|
| A A A   | VRV               | RXYQ-M |
| A 9 6   | VRV Heat Recovery | REYQ-M |

(V2775)

## 1.5 Remote Controller Service Mode

### How to Enter the Service Mode

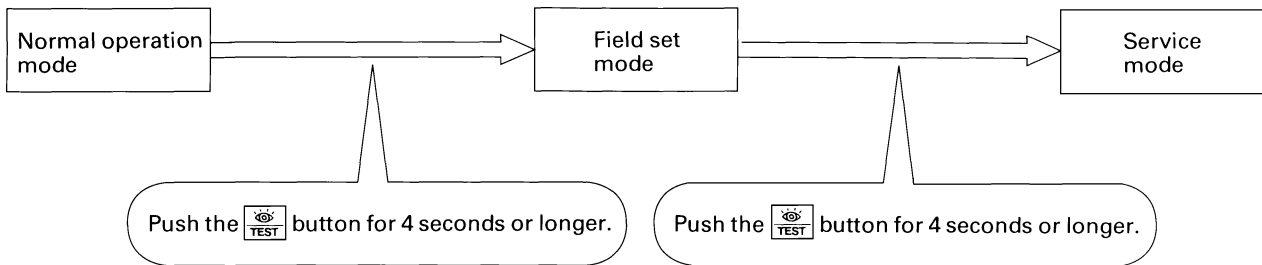

(VF020)

### Service Mode Operation Method

#### 1. Select the mode No.

Set the desired mode No. with the button.

(For wireless remote controller, Mode 43 only can be set.)

#### 2. Select the unit No. (For group control only)

Select the indoor unit No. to be set with the time mode . (For wireless remote controller, button.)

#### 3. Make the settings required for each mode. (Modes 41, 44, 45)

In case of Mode 44, 45, push button to be able to change setting before setting work. (LCD "code" blinks.)

For details, refer to the table in next page.









#### 4. Define the setting contents. (Modes 44, 45)

Define by pushing the timer button.

After defining, LCD "code" changes blinking to ON.

#### 5. Return to the normal operation mode.

Push the button one time.

| Mode No | Function  | Contents and operation method   | Remote controller display example  |
|---------|---|---|--|
| 40      | Malfunction hysteresis display                          | <p>Display malfunction hysteresis.</p> <p>The history No. can be changed with the  button.</p>   | <p>Unit 1<br/>Malfunction code <b>40</b></p> <p>2-U4<br/>Malfunction code</p> <p>History No: 1 - 9<br/>1: Latest</p> <p>(VE007)</p>  |
| 41      | Display of sensor and address data                      | <p>Display various types of data.</p> <p>Select the data to be displayed with the  button. Sensor data<br/>                     0: Thermostat sensor in remote controller.<br/>                     1: Suction<br/>                     2: Liquid pipe<br/>                     3: Gas pipe</p> <p>Address data<br/>                     4: Indoor unit address<br/>                     5: Outdoor unit address<br/>                     6: BS unit address<br/>                     7: Zone control address<br/>                     8: Cool/heat group address<br/>                     9: Demand / low noise address</p> | <p>Sensor data display</p> <p>Unit No. Sensor type</p> <p>1 1 <b>41</b></p> <p>2 7<br/>Temperature °C</p> <p>Address display</p> <p>Unit No. Address type</p> <p>1 8 <b>41</b></p> <p>1<br/>Address</p> <p>(VE008)</p> |
| 43      | Forced fan ON   | <p>Manually turn the fan ON by each unit. (When you want to search for the unit No.)</p> <p>By selecting the unit No. with the  button, you can turn the fan of each indoor unit on (forced ON) individually.</p>  | <p>Unit 1</p> <p><b>43</b></p> <p>(VE009)</p>  |
| 44      | Individual setting                                      | <p>Set the fan speed and air flow direction by each unit</p> <p>Select the unit No. with the time mode  button. Set the fan speed with the  button.</p> <p>Set the air flow direction with the  button.</p>  | <p>Unit 1<br/>Code</p> <p><b>44</b></p> <p>1 3</p> <p>Fan speed 1: Low<br/>3: High</p> <p>Air flow direction<br/>P0 - P4</p> <p>(VE010)</p>  |
| 45      | Unit No. transfer                                       | <p>Transfer unit No.</p> <p>Select the unit No. with the  button. Set the unit No. after transfer with the  button.</p>   | <p>Present unit No.</p> <p>Unit 1<br/>Code</p> <p>0 2 <b>45</b></p> <p>Unit No. after transfer</p> <p>(VE011)</p>  |
| 46      | This function is not used by VRV R-410A Heat Pump 50Hz. |   |  |
| 47      |   |   |  |

## 1.6 Remote Controller Self-Diagnosis Function

The remote controller switches are equipped with a self diagnosis function so that more appropriate maintenance can be carried out. If a malfunction occurs during operation, the operation lamp, malfunction code and display of malfunctioning unit No. let you know the contents and location of the malfunction.

When there is a stop due to malfunction, the contents of the malfunction given below can be diagnosed by a combination of operation lamp, INSPECTION display of the liquid crystal display and display of malfunction code. It also lets you know the unit No. during group control.

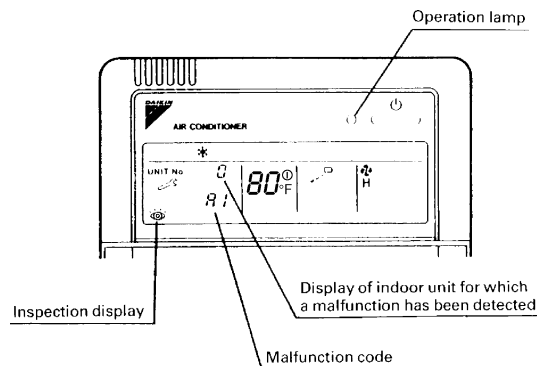

(VL050)

○ : ON ● : OFF ◐ : Blink

|             | Malfunction code | Operation lamp | Inspection display | Unit No.   | Malfunction contents   | Page Referred   |
|-------------|------------------|----------------|--------------------|--|--|-----------------|
| Indoor Unit | A0               | ◐              | ◐                  | ◐  | Error of external protection device  | 120             |
|             | A1               | ◐              | ◐                  | ◐  | PC board defect, E <sup>2</sup> PROM defect  | 121             |
|             | A3               | ◐              | ◐                  | ◐  | Malfunction of drain level control system (S1L)  | 122             |
|             | A6               | ◐              | ◐                  | ◐  | Fan motor (M1F) lock, overload   | 124             |
|             | A7               | ○              | ●                  | ◐  | Malfunction of swing flap motor (MA)   | 125             |
|             | A9               | ◐              | ◐                  | ◐  | Malfunction of moving part of electronic expansion valve (20E)   | 127             |
|             | AF               | ○              | ●                  | ◐  | Drain level above limit  | 129             |
|             | AH               | ○              | ●                  | ◐  | Malfunction of air filter maintenance  | —               |
|             | AJ               | ◐              | ◐                  | ◐  | Malfunction of capacity setting  | 130             |
|             | C4               | ◐              | ◐                  | ◐  | Malfunction of thermistor (R2T) for heat exchange (loose connection, disconnection, short circuit, failure)        | 131             |
|             | C5               | ◐              | ◐                  | ◐  | Malfunction of thermistor (R3T) for gas pipes (loose connection, disconnection, short circuit, failure)            | 132             |
|             | C9               | ◐              | ◐                  | ◐  | Malfunction of thermistor (R1T) for air inlet (loose connection, disconnection, short circuit, failure)            | 133             |
|             | CJ               | ○              | ○                  | ○  | Malfunction of thermostat sensor in remote controller  | 134             |
|             | Outdoor Unit     | E1             | ◐                  | ◐  | ◐  | PC board defect |
| E3          |                  | ◐              | ◐                  | ◐  | Actuation of high pressure switch  | 136             |
| E4          |                  | ◐              | ◐                  | ◐  | Actuation of low pressure sensor   | 137             |
| E5          |                  | ◐              | ◐                  | ◐  | Compressor motor lock (INV compressor)   | 139             |
| E6          |                  | ◐              | ◐                  | ◐  | Standard compressor lock or over current   | 141             |
| E7          |                  | ◐              | ◐                  | ◐  | Malfunction of outdoor unit fan motor  | 142             |
| E9          |                  | ◐              | ◐                  | ◐  | Malfunction of moving part of electronic expansion valve (Y1E~3E)  | 144             |
| F3          |                  | ◐              | ◐                  | ◐  | Abnormal discharge pipe temperature  | 146             |
| F6          |                  | ◐              | ◐                  | ◐  | Refrigerant overcharged  | 147             |
| H3          |                  | ○              | ●                  | ◐  | Malfunction of High pressure switch  | —               |
| H4          |                  | ◐              | ◐                  | ◐  | Actuation of Low pressure switch   | —               |
| H7          |                  | ◐              | ◐                  | ◐  | Abnormal outdoor fan motor signal  | 148             |
| H9          |                  | ◐              | ◐                  | ◐  | Malfunction of thermistor (R1T) for outdoor air (loose connection, disconnection, short circuit, failure)          | 150             |
| J2          |                  | ◐              | ◐                  | ◐  | Current sensor malfunction   | 151             |
| J3          |                  | ◐              | ◐                  | ◐  | Malfunction of discharge pipe thermistor (R31~33T) (loose connection, disconnection, short circuit, failure)       | 152             |
| J5          |                  | ◐              | ◐                  | ◐  | Malfunction of thermistor (R2T) for suction pipe (loose connection, disconnection, short circuit, failure)         | 153             |
| J6          |                  | ◐              | ◐                  | ◐  | Malfunction of thermistor (R4T) for heat exchanger (loose connection, disconnection, short circuit, failure)       | 154             |
| J7          |                  | ◐              | ◐                  | ◐  | Malfunction of receiver outlet liquid pipe thermistor (R6T)  | 155             |
| J8          |                  | ◐              | ◐                  | ◐  | Malfunction of thermistor (R7T) for oil equalizing pipe. (loose connection, disconnection, short circuit, failure) | 156             |
| J9          |                  | ◐              | ◐                  | ◐  | Malfunction of sub-cooling heat exchanger gas pipe thermistor (R5T)  | 157             |
| JA          |                  | ◐              | ◐                  | ◐  | Malfunction of discharge pipe pressure sensor  | 158             |
| JC          | ◐                | ◐              | ◐                  | Malfunction of suction pipe pressure sensor            | 160  |                 |
| L0          | ◐                | ◐              | ◐                  | Inverter system error                                  | —  |                 |
| L4          | ◐                | ◐              | ◐                  | Malfunction of inverter radiating fin temperature rise | 161  |                 |
| L5          | ◐                | ◐              | ◐                  | Inverter compressor motor grounding, short circuit     | 162  |                 |
| L6          | ◐                | ◐              | ◐                  | Compressor motor coil grounding on short circuit       | —  |                 |
| L8          | ◐                | ◐              | ◐                  | Inverter current abnormal                              | 163  |                 |
| L9          | ◐                | ◐              | ◐                  | Inverter start up error                                | 165  |                 |

|  | Malfunction code | Operation lamp | Inspection display | Unit No. | Malfunction contents   | Page Referred |
|--|------------------|----------------|--------------------|----------|--|---------------|
| Outdoor Unit                                 | LA               | ●              | ●                  | ●        | Malfunction of power unit  | —             |
|  | LC               | ●              | ●                  | ●        | Malfunction of transmission between inverter and control PC board  | 166           |
|  | P1               | ●              | ●                  | ●        | Inverter over-ripple protection  | 168           |
|  | P4               | ●              | ●                  | ●        | Malfunction of inverter radiating fin temperature rise sensor  | 170           |
|  | PJ               | ●              | ●                  | ●        | Faulty field setting or faulty combination of PC board   | 171           |
| System                                       | U0               | ○              | ●                  | ●        | Low pressure drop due to refrigerant shortage or electronic expansion valve failure                        | 172           |
|  | U1               | ●              | ●                  | ●        | Reverse phase / open phase   | 174           |
|  | U2               | ●              | ●                  | ●        | Power supply insufficient or instantaneous failure   | 175           |
|  | U3               | ●              | ●                  | ●        | Check operation is not conducted.  | 177           |
|  | U4               | ●              | ●                  | ●        | Malfunction of transmission between indoor and outdoor units   | 178           |
|  | U5               | ●              | ●                  | ●        | Malfunction of transmission between remote controller and indoor unit                                      | 180           |
|  | U5               | ●              | ○                  | ●        | Failure of remote controller PC board or setting during control by remote controller                       | 180           |
|  | U7               | ●              | ●                  | ●        | Malfunction of transmission between outdoor units  | 181           |
|  | U8               | ●              | ●                  | ●        | Malfunction of transmission between main and sub remote controllers (malfunction of sub remote controller) | 183           |
|  | U9               | ●              | ●                  | ●        | Malfunction of transmission between indoor unit and outdoor unit in the same system                        | 184           |
|  | UA               | ●              | ●                  | ●        | Excessive number of indoor units etc.  | 186           |
|  | UC               | ○              | ○                  | ○        | Address duplication of central remote controller   | 188           |
|  | UE               | ●              | ●                  | ●        | Malfunction of transmission between central remote controller and indoor unit                              | 189<br>200    |
|  | UF               | ●              | ●                  | ●        | Refrigerant system not set, incompatible wiring / piping   | 191           |
|  | UH               | ●              | ●                  | ●        | Malfunction of system, refrigerant system address undefined  | 192           |
| Central remote Controller and Schedule Timer | M1               | ○ or ●         | ●                  | ●        | Central remote controller or schedule timer PC board defect  | 194<br>202    |
|  | M8               | ○ or ●         | ●                  | ●        | Malfunction of transmission between optional controllers for centralized control                           | 195<br>203    |
|  | MA               | ○ or ●         | ●                  | ●        | Improper combination of optional controllers for centralized control                                       | 197<br>205    |
|  | MC               | ○ or ●         | ●                  | ●        | Address duplication, improper setting  | 199<br>207    |
| Heat Reclaim Ventilation                     | 64               | ○              | ●                  | ●        | Indoor unit's air thermistor error   | —             |
|  | 65               | ○              | ●                  | ●        | Outside air thermistor error   | —             |
|  | 6A               | ○              | ●                  | ●        | Damper system alarm  | —             |
|  | 6A               | ●              | ●                  | ●        | Damper system + thermistor error   | —             |
|  | 6F               | ○              | ●                  | ●        | Malfunction of simple remote controller  | —             |
|  | 6H               | ○              | ●                  | ●        | Malfunction of door switch or connector  | —             |
|  | 94               | ●              | ●                  | ●        | Internal transmission error  | —             |

 The system operates for malfunction codes indicated in black squares, however, be sure to check and repair.



Malfunction code indication by outdoor unit PCB

To enter the monitor mode, push the MODE button (BS1) when in "Setting mode 1".

<Selection of setting item>

Push the SET button (BS2) and set the LED display to a setting item.

<Confirmation of malfunction 1>

Push the RETURN button (BS3) once to display "First digit" of malfunction code.

<Confirmation of malfunction 2>

Push the SET button (BS2) once to display "Second digit" of malfunction code.

<Confirmation of malfunction 3>

Push the SET button (BS2) once to display "master or slave1 or slave2" and "malfunction location".

Push the RETURN button (BS3) and switches to the initial status of "Monitor mode".

\* Push the MODE button (BS1) and returns to "Setting mode 1".

Detail description on next page.

| Contents of malfunction   |  | Malfunction code |
|---|--|------------------|
| Abnormal discharge pressure   | HPS activated  | E3               |
| Abnormal suction pressure   | Abnormal Pe  | E4               |
| Compressor lock   | Detection of INV compressor lock   | E5               |
| Activation of OC  | Detection of STD1 compressor lock  | E6               |
|   | Detection of STD2 compressor lock  |                  |
| Over load, over current, abnormal lock of outdoor unit fan motor  | Instantaneous over current of DC fan motor                                 | E7               |
|   | Detection of DC fan motor lock   |                  |
| Malfunction of electronic expansion valve   | EV1  | E9               |
|   | EV2  |                  |
|   | EV3  |                  |
| Abnormal position signal of outdoor unit fan motor  | Abnormal position signal of DC fan motor                                   | H7               |
| Faulty sensor of outdoor air temperature  | Faulty Ta sensor   | H9               |
| Faulty sensor of heat storage unit  |  | HC               |
| Abnormality in water system of heat storage unit  |  | HJ               |
| Transmission error between heat storage unit and controller   |  | HF               |
| Abnormal discharge pipe temperature   | Abnormal Td  | F3               |
| Abnormal heat exchanger temperature   | Refrigerant over charge  | F6               |
| Faulty current sensor   | Faulty CT1 sensor  | J2               |
|   | Faulty CT2 sensor  |                  |
| Faulty sensor of discharge pipe temperature   | Faulty Tdi sensor  | J3               |
|   | Faulty Tds1 sensor   |                  |
|   | Faulty Tds2 sensor   |                  |
| Faulty sensor of suction pipe temperature   | Faulty Ts sensor   | J5               |
| Faulty sensor of heat exchanger temperature   | Faulty Tb sensor   | J6               |
| Faulty sensor of receiver temperature   | Faulty Tl sensor   | J7               |
| Faulty sensor of oil pressure equalizing pipe temperature   | Faulty To sensor   | J8               |
| Faulty sensor of subcool heat exchanger temperature   | Faulty Tsh sensor  | J9               |
| Faulty sensor of discharge pressure   | Faulty Pc sensor   | JA               |
| Faulty sensor of suction pressure   | Faulty Pe sensor   | JC               |
| Inverter radiation fin temperature rising   | Over heating of inverter radiation fin temperature                         | L4               |
| DC output over current  | Inverter instantaneous over current  | L5               |
|   | Electronic thermal switch 1  |                  |
|   | Electronic thermal switch 2  |                  |
|   | Out-of-step  |                  |
|   | Speed down after startup   |                  |
| Stall prevention (Limit time)   | Stall prevention (Current increasing)                                      | L9               |
|   | Stall prevention (Faulty startup)  |                  |
|   | Abnormal wave form in startup  |                  |
|   | Out-of-step  |                  |
| Transmission error between inverter and outdoor unit  | Inverter transmission error  | LC               |
| Open phase/Power supply imbalance   | Imbalance of inverter power supply voltage                                 | P1               |
| Faulty temperature sensor inside switch box   | Faulty thermistor of inverter box  | P3               |
| Faulty temperature sensor of inverter radiation fin   | Faulty thermistor of inverter fin  | P4               |
| Incorrect combination of inverter and fan driver  | Faulty field setting or faulty combination of PC board                     | PJ               |
| Gas shortage  | Gas shortage alarm   | U0               |
| Reverse phase   | Reverse phase error  | U1               |
| Abnormal power supply voltage   | Insufficient inverter voltage  | U2               |
|   | Inverter open phase (phase T)  |                  |
|   | Charging error of capacitor in inverter main circuit                       |                  |
| No implementation of test-run   |  | U3               |
| Transmission error between indoor and outdoor unit  | I/O transmission error   | U4               |
| Transmission error between outdoor units, transmission error between thermal storage units, duplication of IC address | O/O transmission error   | U7               |
| Transmission error of other system  | Indoor unit system malfunction in other system or other unit of own system | U9               |
| Erroneous on-site setting   | Abnormal connection with excessive number of indoor units                  | UA               |
|   | Conflict of refrigerant type in indoor units                               |                  |
| Faulty system function  | Incorrect wiring (Auto address error)                                      | UH               |
| Transmission error in accessory devices, conflict in wiring and piping, no setting for system                         | Malfunction of multi level converter, abnormality in conflict check        | UJ               |
|   |  | UF               |

| Malfunction code | Confirmation of malfunction 1 |     |     |     |     |     |     | Confirmation of malfunction 2 |     |     |     |     |     |     | Confirmation of malfunction 3 |     |     |     |     |     |     |
|------------------|-------------------------------|-----|-----|-----|-----|-----|-----|-------------------------------|-----|-----|-----|-----|-----|-----|-------------------------------|-----|-----|-----|-----|-----|-----|
|                  | H1P                           | H2P | H3P | H4P | H5P | H6P | H7P | H1P                           | H2P | H3P | H4P | H5P | H6P | H7P | H1P                           | H2P | H3P | H4P | H5P | H6P | H7P |
| E3               | ○                             |     |     | ●   | ●   | ○   | ○   | ○                             |     |     | ●   | ●   | ○   | ○   | ○                             |     |     |     |     | ●   | ●   |
| E4               |                               |     |     |     |     |     | ○   |                               |     |     | ●   | ○   | ●   | ●   | ○                             |     |     |     |     | ●   | ●   |
| E5               |                               |     |     |     |     |     | ○   |                               |     |     | ●   | ○   | ●   | ○   | ○                             |     |     |     |     | ●   | ●   |
| E6               |                               |     |     |     |     |     | ○   |                               |     |     | ●   | ○   | ○   | ●   | ○                             |     |     |     |     | ●   | ○   |
| E7               |                               |     |     |     |     |     | ○   |                               |     |     | ●   | ○   | ○   | ○   | ○                             |     |     |     |     | ○   | ●   |
| E9               |                               |     |     |     |     |     | ○   |                               |     |     | ○   | ●   | ●   | ○   | ○                             |     |     |     |     | ●   | ○   |
| H7               | ○                             |     |     | ●   | ○   | ●   | ●   | ○                             |     |     | ●   | ○   | ○   | ○   | ○                             |     |     |     |     | ●   | ○   |
| H9               |                               |     |     |     |     |     | ○   |                               |     |     | ○   | ●   | ●   | ○   | ○                             |     |     |     |     | ●   | ●   |
| HC               |                               |     |     |     |     |     | ○   |                               |     |     | ○   | ○   | ●   | ●   | ○                             |     |     |     |     | ●   | ●   |
| HJ               |                               |     |     |     |     |     | ○   |                               |     |     | ○   | ○   | ●   | ○   | ○                             |     |     |     |     | ●   | ●   |
| HF               |                               |     |     |     |     |     | ○   |                               |     |     | ○   | ○   | ○   | ○   | ○                             |     |     |     |     | ●   | ●   |
| F3               | ○                             |     |     | ●   | ○   | ●   | ○   | ○                             |     |     | ●   | ●   | ○   | ○   | ○                             |     |     |     |     | ●   | ●   |
| F6               |                               |     |     |     |     |     | ○   |                               |     |     | ●   | ○   | ○   | ○   | ○                             |     |     |     |     | ●   | ●   |
| J2               | ○                             |     |     | ●   | ○   | ○   | ●   | ○                             |     |     | ●   | ●   | ○   | ○   | ○                             |     |     |     |     | ●   | ○   |
| J3               |                               |     |     |     |     |     | ○   |                               |     |     | ●   | ●   | ○   | ○   | ○                             |     |     |     |     | ○   | ○   |
| J5               |                               |     |     |     |     |     | ○   |                               |     |     | ●   | ○   | ●   | ○   | ○                             |     |     |     |     | ●   | ●   |
| J6               |                               |     |     |     |     |     | ○   |                               |     |     | ●   | ○   | ○   | ●   | ○                             |     |     |     |     | ●   | ●   |
| J7               |                               |     |     |     |     |     | ○   |                               |     |     | ●   | ○   | ○   | ○   | ○                             |     |     |     |     | ●   | ●   |
| J8               |                               |     |     |     |     |     | ○   |                               |     |     | ○   | ●   | ●   | ●   | ○                             |     |     |     |     | ●   | ●   |
| J9               |                               |     |     |     |     |     | ○   |                               |     |     | ○   | ●   | ●   | ○   | ○                             |     |     |     |     | ●   | ●   |
| JA               |                               |     |     |     |     |     | ○   |                               |     |     | ○   | ●   | ●   | ○   | ○                             |     |     |     |     | ●   | ●   |
| JC               |                               |     |     |     |     |     | ○   |                               |     |     | ○   | ○   | ○   | ○   | ○                             |     |     |     |     | ●   | ●   |
| L4               | ○                             |     |     | ●   | ○   | ○   | ○   | ○                             |     |     | ●   | ○   | ●   | ●   | ○                             |     |     |     |     | ●   | ●   |
| L5               |                               |     |     |     |     |     | ○   |                               |     |     | ●   | ○   | ●   | ○   | ○                             |     |     |     |     | ●   | ●   |
| L8               |                               |     |     |     |     |     | ○   |                               |     |     | ○   | ●   | ●   | ●   | ○                             |     |     |     |     | ●   | ●   |
| L9               |                               |     |     |     |     |     | ○   |                               |     |     | ○   | ●   | ●   | ○   | ○                             |     |     |     |     | ●   | ●   |
| LC               |                               |     |     |     |     |     | ○   |                               |     |     | ○   | ○   | ●   | ●   | ○                             |     |     |     |     | ●   | ●   |
| P1               | ○                             |     |     | ○   | ●   | ●   | ●   | ○                             |     |     | ●   | ●   | ●   | ○   | ○                             |     |     |     |     | ●   | ●   |
| P3               |                               |     |     |     |     |     | ○   |                               |     |     | ●   | ●   | ○   | ○   | ○                             |     |     |     |     | ●   | ●   |
| P4               |                               |     |     |     |     |     | ○   |                               |     |     | ●   | ○   | ●   | ●   | ○                             |     |     |     |     | ●   | ●   |
| PJ               |                               |     |     |     |     |     | ○   |                               |     |     | ○   | ○   | ●   | ○   | ○                             |     |     |     |     | ●   | ●   |
| U0               | ○                             |     |     | ○   | ●   | ●   | ○   | ○                             |     |     | ●   | ○   | ○   | ○   | ○                             |     |     |     |     | ●   | ●   |
| U1               |                               |     |     |     |     |     | ○   |                               |     |     | ●   | ●   | ●   | ○   | ○                             |     |     |     |     | ●   | ●   |
| U2               |                               |     |     |     |     |     | ○   |                               |     |     | ●   | ●   | ○   | ●   | ○                             |     |     |     |     | ●   | ●   |
| U3               |                               |     |     |     |     |     | ○   |                               |     |     | ●   | ●   | ○   | ○   | ○                             |     |     |     |     | ●   | ●   |
| U4               |                               |     |     |     |     |     | ○   |                               |     |     | ●   | ○   | ●   | ●   | ○                             |     |     |     |     | ●   | ●   |
| U7               |                               |     |     |     |     |     | ○   |                               |     |     | ●   | ○   | ○   | ○   | ○                             |     |     |     |     | ●   | ●   |
| U9               |                               |     |     |     |     |     | ○   |                               |     |     | ○   | ●   | ●   | ○   | ○                             |     |     |     |     | ●   | ●   |
| UA               |                               |     |     |     |     |     | ○   |                               |     |     | ○   | ●   | ○   | ●   | ○                             |     |     |     |     | ●   | ●   |
| UH               |                               |     |     |     |     |     | ○   |                               |     |     | ○   | ●   | ○   | ○   | ○                             |     |     |     |     | ●   | ●   |
| UJ               |                               |     |     |     |     |     | ○   |                               |     |     | ○   | ○   | ●   | ○   | ○                             |     |     |     |     | ●   | ●   |
| UF               |                               |     |     |     |     |     | ○   |                               |     |     | ○   | ○   | ○   | ○   | ○                             |     |     |     |     | ●   | ●   |

○ : ON  
 ○ : Blink  
 ● : OFF

Malfunction code 1st digit display section

○ : ON  
 ○ : Blink  
 ● : OFF

Malfunction code 2nd digit display section

Master ● ● ●  
 Slave 1 ● ● ○  
 Slave 2 ○ ● ●

Malfunction location

## 2. Troubleshooting by Indication on the Remote Controller

### 2.1 “A0” Indoor Unit: Error of External Protection Device

|                                 |   |
|---------------------------------|---|
| Remote Controller Display       | A0  |
| Applicable Models               | All indoor unit models  |
| Method of Malfunction Detection | Detect open or short circuit between external input terminals in indoor unit.   |
| Malfunction Decision Conditions | When an open circuit occurs between external input terminals with the remote controller set to “external ON/OFF terminal”.  |
| Supposed Causes                 | <ul style="list-style-type: none"> <li>■ Actuation of external protection device</li> <li>■ Improper field set</li> <li>■ Defect of indoor unit PC board</li> </ul> |

#### Troubleshooting



**Caution**

Be sure to turn off power switch before connect or disconnect connector, or parts damage may be occurred.

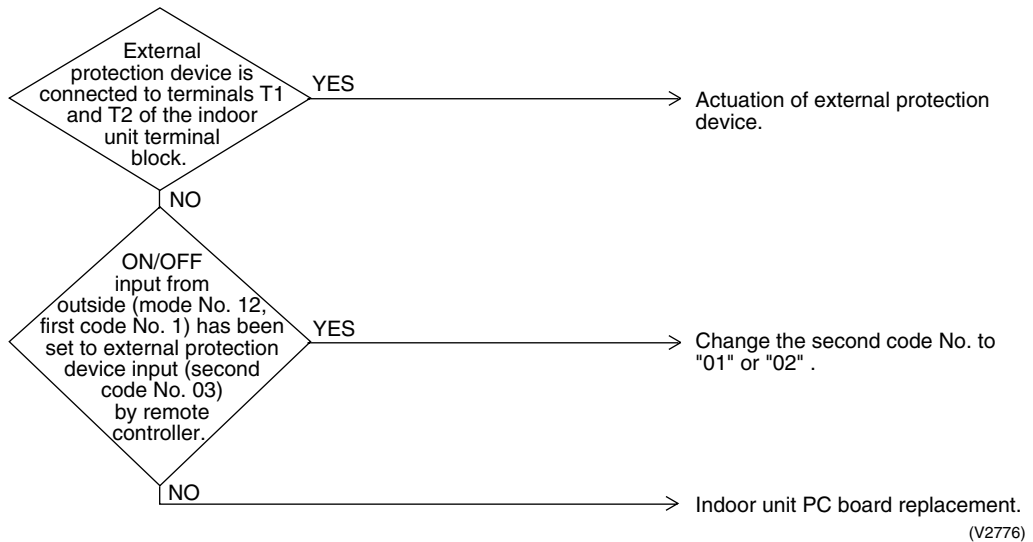

## 2.2 “A1” Indoor Unit: PC Board Defect

Remote  
Controller  
Display

A1

Applicable  
Models

All indoor unit models

Method of  
Malfunction  
Detection

Check data from E<sup>2</sup>PROM.

Malfunction  
Decision  
Conditions

When data could not be correctly received from the E<sup>2</sup>PROM  
E<sup>2</sup>PROM : Type of nonvolatile memory. Maintains memory contents even when the power supply is turned off.

Supposed  
Causes

- Defect of indoor unit PC board

Troubleshooting



**Caution**

Be sure to turn off power switch before connect or disconnect connector, or parts damage may be occurred.

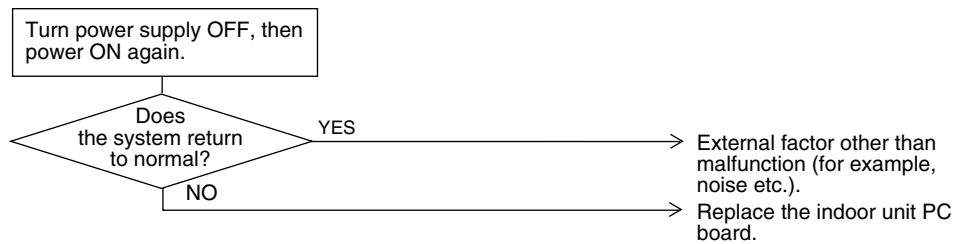

(V2777)

## 2.3 “A3” Indoor Unit: Malfunction of Drain Level Control System (S1L)

|   |   |
|---|---|
| <p><b>Remote Controller Display</b></p>       | <p>A3</p>   |
| <p><b>Applicable Models</b></p>               | <p>FXFQ, FXDQ, FXSQ, FXMQ, FXHQ, FXAQ</p>   |
| <p><b>Method of Malfunction Detection</b></p> | <p>By float switch OFF detection</p>  |
| <p><b>Malfunction Decision Conditions</b></p> | <p>When rise of water level is not a condition and the float switch goes OFF.</p>   |
| <p><b>Supposed Causes</b></p>                 | <ul style="list-style-type: none"> <li>■ 208~230V power supply is not provided</li> <li>■ Defect of float switch or short circuit connector</li> <li>■ Defect of drain pump</li> <li>■ Drain clogging, upward slope, etc.</li> <li>■ Defect of indoor unit PC board</li> <li>■ Loose connection of connector</li> </ul> |

## Troubleshooting



**Caution** Be sure to turn off power switch before connect or disconnect connector, or parts damage may be occurred.

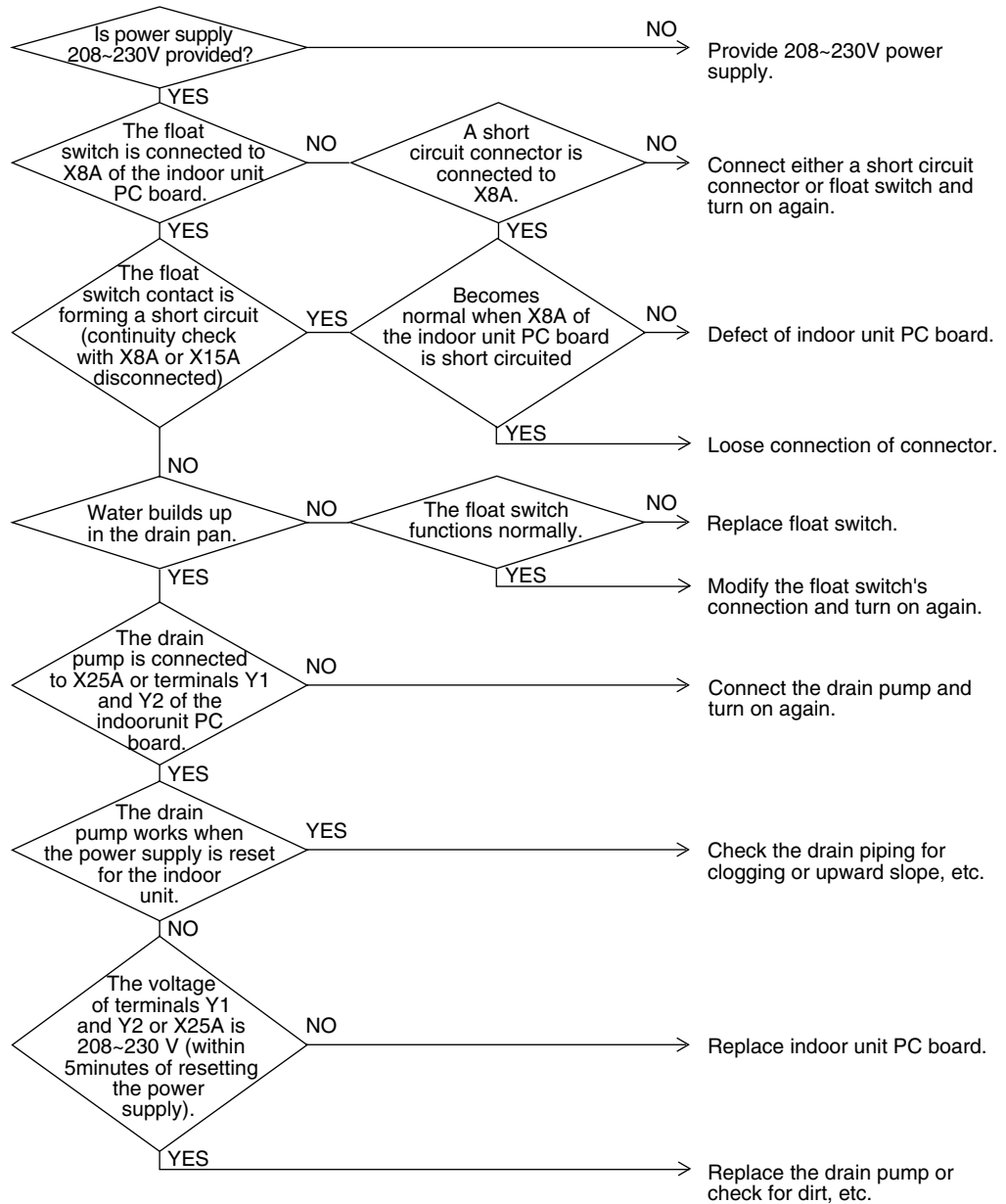

(V2778)

## 2.4 “R6” Indoor Unit: Fan Motor (M1F) Lock, Overload

|  |  |
|--|--|
| <b>Remote Controller Display</b>       | R6   |
| <b>Applicable Models</b>               | All indoor unit models   |
| <b>Method of Malfunction Detection</b> | Detection by failure of signal for detecting number of turns to come from the fan motor  |
| <b>Malfunction Decision Conditions</b> | When number of turns can't be detected even when output voltage to the fan is maximum  |
| <b>Supposed Causes</b>                 | <ul style="list-style-type: none"> <li>■ Fan motor lock</li> <li>■ Disconnected or faulty wiring between fan motor and PC board</li> </ul> |

### Troubleshooting



**Caution**

Be sure to turn off power switch before connect or disconnect connector, or parts damage may be occurred.

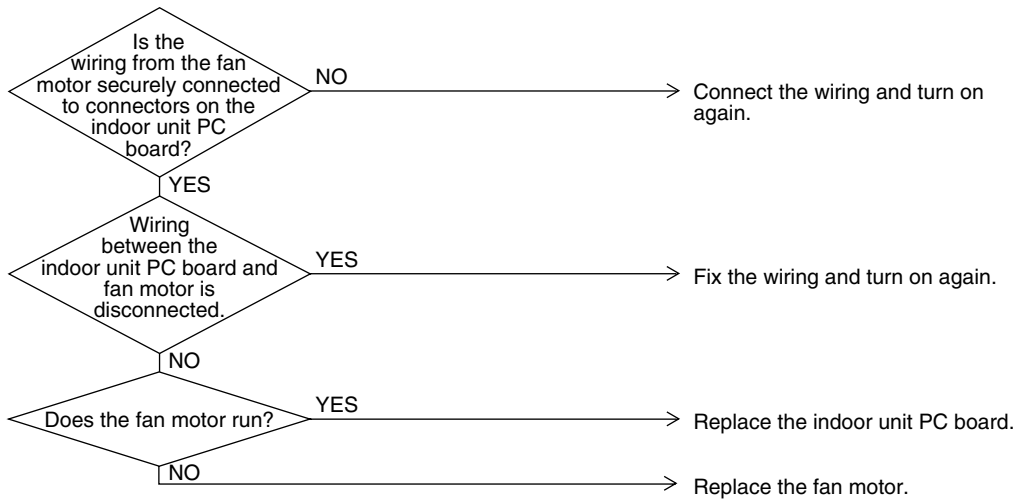

(V2779)

## 2.5 “A7” Indoor Unit: Malfunction of Swing Flap Motor (MA)

### Remote Controller Display

A7

### Applicable Models

FXHQ only

### Method of Malfunction Detection

Utilizes ON/OFF of the limit switch when the motor turns.

### Malfunction Decision Conditions

When ON/OFF of the microswitch for positioning cannot be reversed even though the swing flap motor is energized for a specified amount of time (about 30 seconds).

### Supposed Causes

- Defect of swing motor
- Defect of connection cable (power supply and limit switch)
- Defect of air flow direction adjusting flap-cam
- Defect of indoor unit PC board



Troubleshooting



**Caution** Be sure to turn off power switch before connect or disconnect connector, or parts damage may be occurred.

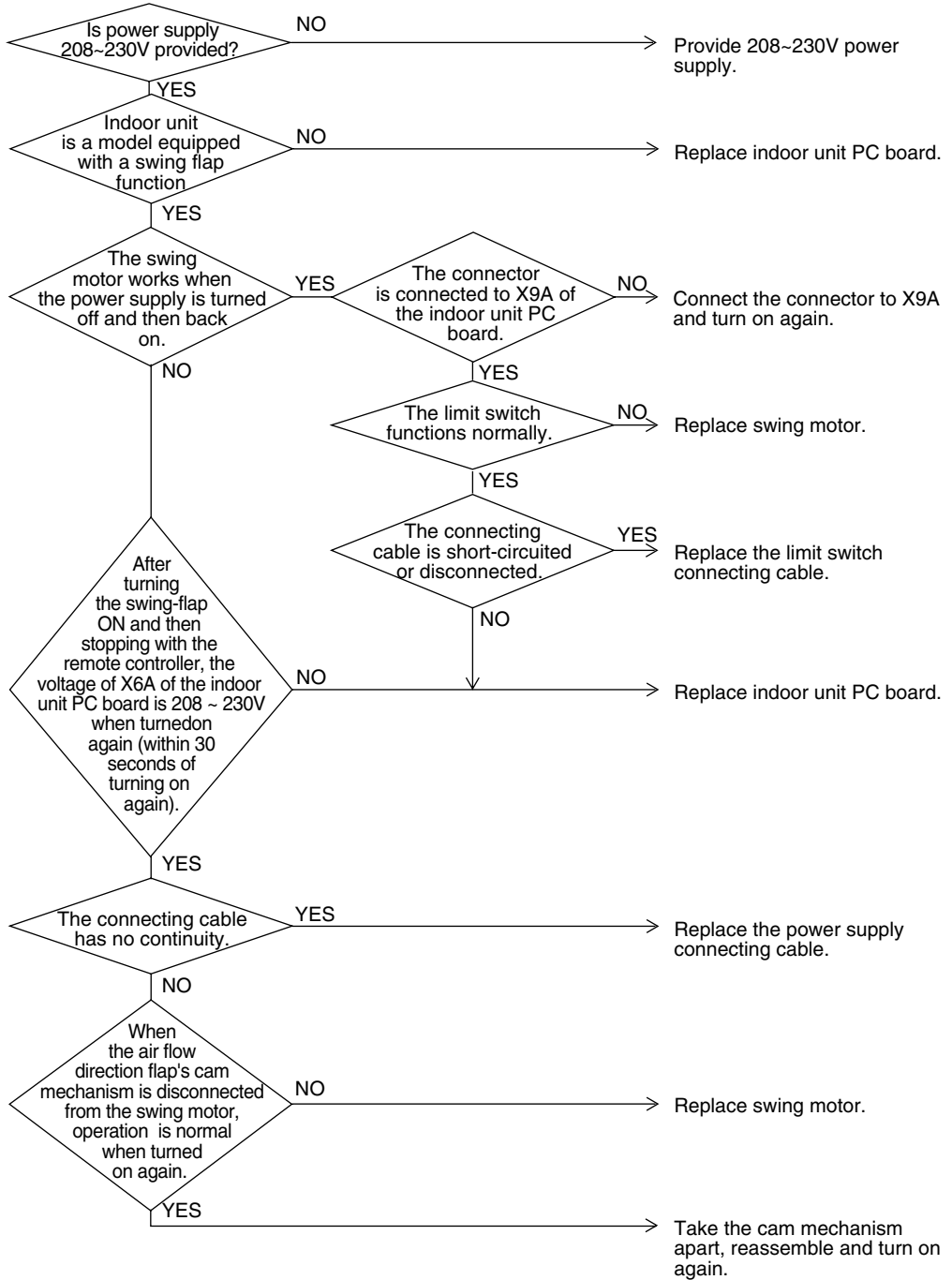

(V2780)

## 2.6 “R3” Indoor Unit: Malfunction of Moving Part of Electronic Expansion Valve (20E)

|  |  |
|--|--|
| <b>Remote Controller Display</b>       | R3   |
| <b>Applicable Models</b>               | All indoor unit models   |
| <b>Method of Malfunction Detection</b> | Use a microcomputer to check the electronic expansion valve for coil conditions.   |
| <b>Malfunction Decision Conditions</b> | When the pin input of the electronic expansion valve is not normal while in the initialization of the microcomputer.   |
| <b>Supposed Causes</b>                 | <ul style="list-style-type: none"> <li>■ Malfunction of moving part of electronic expansion valve</li> <li>■ Defect of indoor unit PC board</li> <li>■ Defect of connecting cable</li> </ul> |

### Troubleshooting



**Caution**

Be sure to turn off power switch before connect or disconnect connector, or parts damage may be occurred.

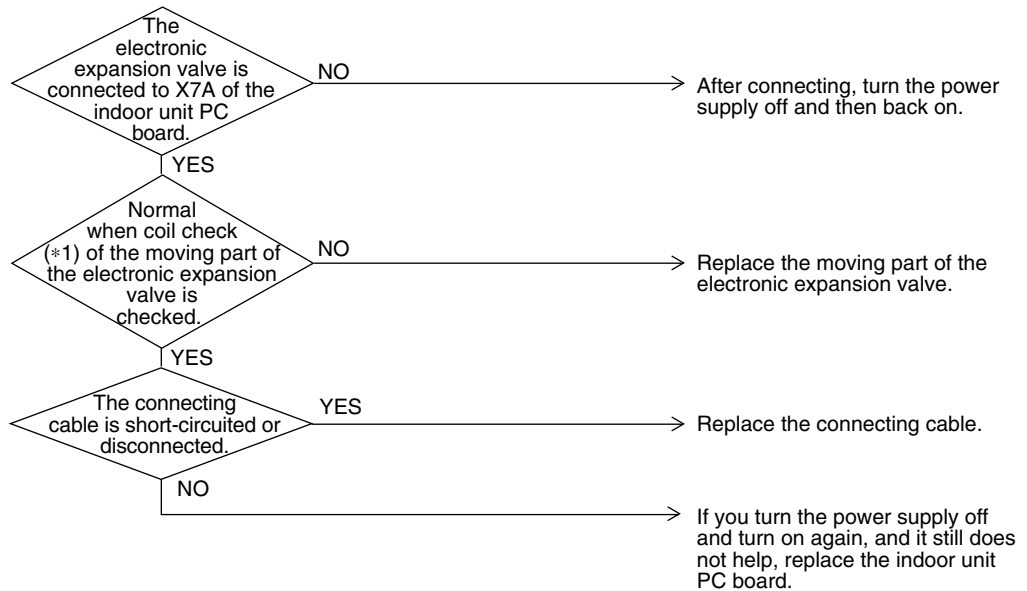

(V2781)

\*1 Coil check method for the moving part of the electronic expansion valve  
 Disconnect the electronic expansion valve from the PC board and check the continuity between the connector pins.

(Normal)

| Pin No.   | 1. White | 2. Yellow | 3. Orange            | 4. Blue              | 5. Red               | 6. Brown             |
|-----------|----------|-----------|----------------------|----------------------|----------------------|----------------------|
| 1. White  |          | x         | ⊙<br>Approx.<br>300Ω | x                    | ○<br>Approx.<br>150Ω | x                    |
| 2. Yellow |          |           | x                    | ⊙<br>Approx.<br>300Ω | x                    | ○<br>Approx.<br>150Ω |
| 3. Orange |          |           |                      | x                    | ○<br>Approx.<br>150Ω | x                    |
| 4. Blue   |          |           |                      |                      | x                    | ○<br>Approx.<br>150Ω |
| 5. Red    |          |           |                      |                      |                      | x                    |
| 6. Brown  |          |           |                      |                      |                      |                      |

⊙ : Continuity Approx. 300Ω

○ : Continuity Approx. 150Ω

x : No continuity

## 2.7 “AF” Indoor Unit: Drain Level above Limit

Remote  
Controller  
Display

AF

Applicable  
Models

FXFQ, FXDQ, FXSQ, FXMQ, FXHQ

Method of  
Malfunction  
Detection

Water leakage is detected based on float switch ON/OFF operation while the compressor is in non-operation.

Malfunction  
Decision  
Conditions

When the float switch changes from ON to OFF while the compressor is in non-operation.

Supposed  
Causes

- Humidifier unit (optional accessory) leaking
- Defect of drain pipe (upward slope, etc.)
- Defect of indoor unit PC board

Troubleshooting



**Caution**

Be sure to turn off power switch before connect or disconnect connector, or parts damage may be occurred.

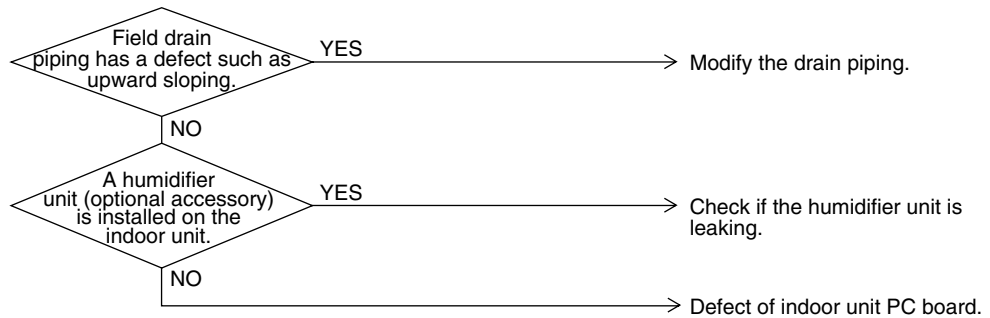

(V2782)

## 2.8 “AU” Indoor Unit: Malfunction of Capacity Determination Device

|  |  |
|--|--|
| <b>Remote controller display</b>       | AU   |
| <b>Applicable Models</b>               | All indoor unit models   |
| <b>Method of Malfunction Detection</b> | Capacity is determined according to resistance of the capacity setting adaptor and the memory inside the IC memory on the indoor unit PC board, and whether the value is normal or abnormal is determined.   |
| <b>Malfunction Decision Conditions</b> | <p>Operation and:</p> <ol style="list-style-type: none"> <li>When the capacity code is not contained in the PC board’s memory, and the capacity setting adaptor is not connected.</li> <li>When a capacity that doesn’t exist for that unit is set.</li> </ol> |
| <b>Supposed Causes</b>                 | <ul style="list-style-type: none"> <li>You have forgotten to install the capacity setting adaptor.</li> <li>Defect of indoor unit PC board</li> </ul>  |

### Troubleshooting



**Caution**

Be sure to turn off power switch before connect or disconnect connector, or parts damage may be occurred.

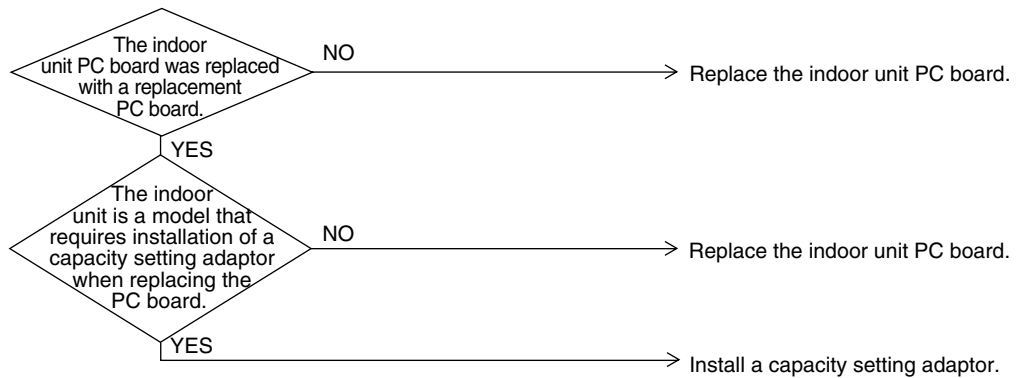

(V2783)

## 2.9 “E4” Indoor Unit: Malfunction of Thermistor (R2T) for Heat Exchanger

|                                 |  |
|---------------------------------|--|
| Remote Controller Display       | E4   |
| Applicable Models               | All indoor unit models   |
| Method of Malfunction Detection | Malfunction detection is carried out by temperature detected by heat exchanger thermistor.   |
| Malfunction Decision Conditions | When the heat exchanger thermistor becomes disconnected or shorted while the unit is running.  |
| Supposed Causes                 | <ul style="list-style-type: none"> <li>■ Defect of thermistor (R2T) for liquid pipe</li> <li>■ Defect of indoor unit PC board</li> </ul> |
| Troubleshooting                 |  |

**Caution**

Be sure to turn off power switch before connect or disconnect connector, or parts damage may be occurred.

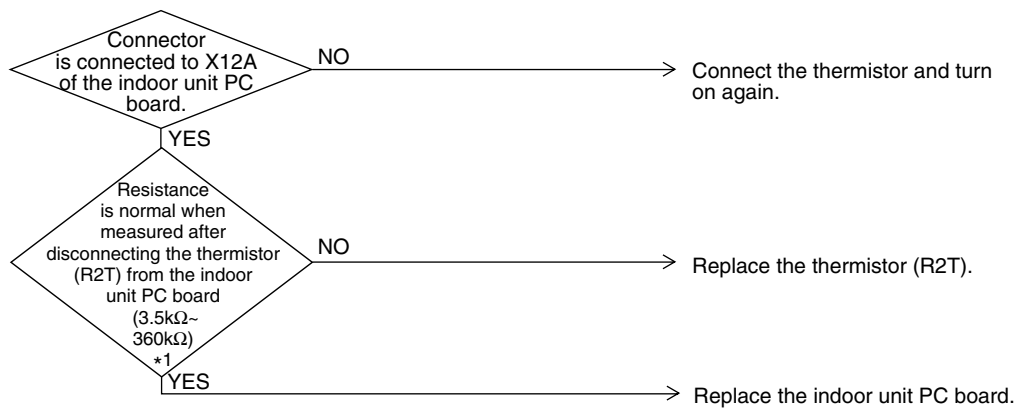

(V2784)



\*1: Refer to thermistor resistance / temperature characteristics table on P239.

## 2.10 “E5” Indoor Unit: Malfunction of Thermistor (R3T) for Gas Pipes

|  |   |
|--|---|
| <b>Remote Controller Display</b>       | E5  |
| <b>Applicable Models</b>               | All indoor unit models  |
| <b>Method of Malfunction Detection</b> | Malfunction detection is carried out by temperature detected by gas pipe thermistor.  |
| <b>Malfunction Decision Conditions</b> | When the gas pipe thermistor becomes disconnected or shorted while the unit is running.   |
| <b>Supposed Causes</b>                 | <ul style="list-style-type: none"> <li>■ Defect of indoor unit thermistor (R3T) for gas pipe</li> <li>■ Defect of indoor unit PC board</li> </ul> |

**Troubleshooting**



**Caution**

Be sure to turn off power switch before connect or disconnect connector, or parts damage may be occurred.

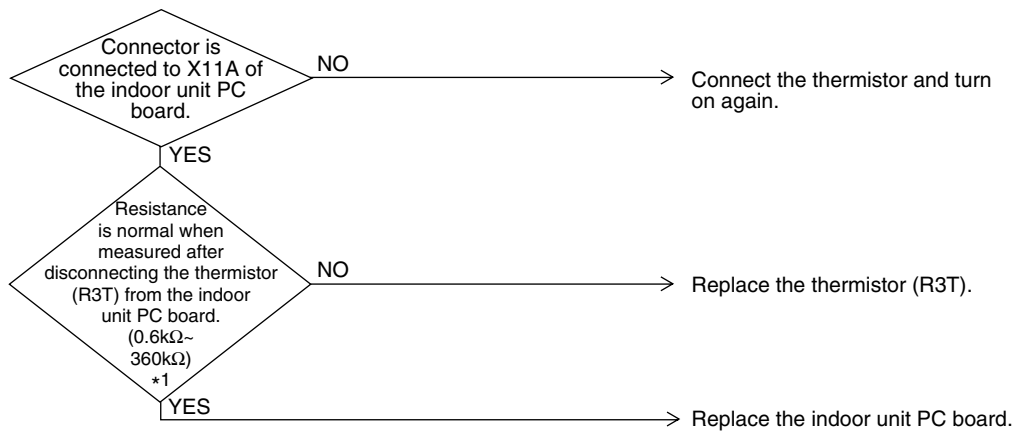

(V2785)



\*1: Refer to thermistor resistance / temperature characteristics table on P239.

## 2.11 “C9” Indoor Unit: Malfunction of Thermistor (R1T) for Suction Air

|                                 |  |
|---------------------------------|--|
| Remote Controller Display       | C9   |
| Applicable Models               | All indoor unit models   |
| Method of Malfunction Detection | Malfunction detection is carried out by temperature detected by suction air temperature thermistor.  |
| Malfunction Decision Conditions | When the suction air temperature thermistor becomes disconnected or shorted while the unit is running.   |
| Supposed Causes                 | <ul style="list-style-type: none"> <li>■ Defect of indoor unit thermistor (R1T) for air inlet</li> <li>■ Defect of indoor unit PC board</li> </ul> |
| Troubleshooting                 |  |

**Caution**

Be sure to turn off power switch before connect or disconnect connector, or parts damage may be occurred.

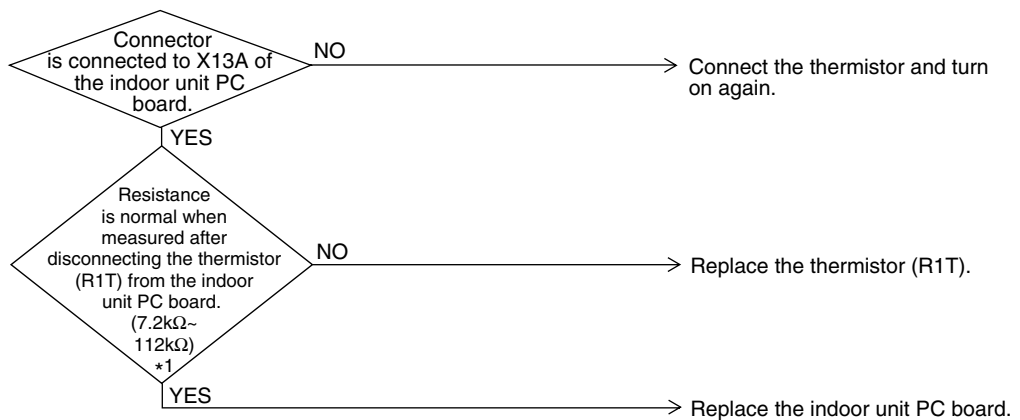

(V2786)



\*1: Refer to thermistor resistance / temperature characteristics table on P239.



## 2.12 “CJ” Indoor Unit: Malfunction of Thermostat Sensor in Remote Controller

|  |  |
|--|--|
| <b>Remote Controller Display</b>       | CJ   |
| <b>Applicable Models</b>               | All indoor unit models   |
| <b>Method of Malfunction Detection</b> | Malfunction detection is carried out by temperature detected by remote controller air temperature thermistor. (Note)                       |
| <b>Malfunction Decision Conditions</b> | When the remote controller air temperature thermistor becomes disconnected or shorted while the unit is running.                           |
| <b>Supposed Causes</b>                 | <ul style="list-style-type: none"> <li>■ Defect of remote controller thermistor</li> <li>■ Defect of remote controller PC board</li> </ul> |

**Troubleshooting**



**Caution**

Be sure to turn off power switch before connect or disconnect connector, or parts damage may be occurred.

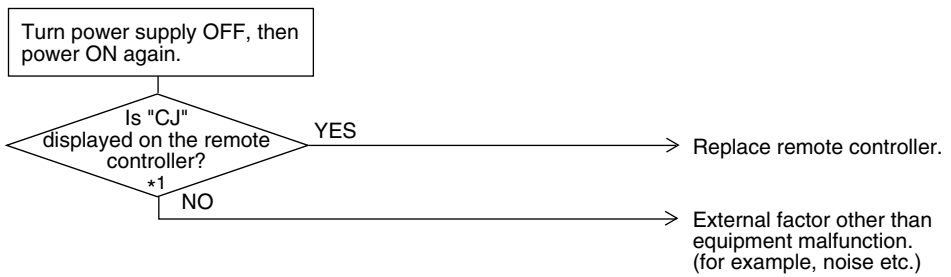

(V2787)



**Note:**

In case of remote controller thermistor malfunction, unit is still operable by suction air thermistor on indoor unit.



\*1: Refer to thermistor resistance / temperature characteristics table on P239.

## 2.13 “E1” Outdoor Unit: PC Board Defect

Remote  
Controller  
Display

E1

Applicable  
Models

RXYQ72M, 96M

Method of  
Malfunction  
Detection

Check data from E<sup>2</sup>PROM

Malfunction  
Decision  
Conditions

When data could not be correctly received from the E<sup>2</sup>PROM  
E<sup>2</sup>PROM : Type of nonvolatile memory. Maintains memory contents even when the power supply is turned off.

Supposed  
Causes

- Defect of outdoor unit PC board (A1P)

Troubleshooting



**Caution**

Be sure to turn off power switch before connect or disconnect connector, or parts damage may be occurred.

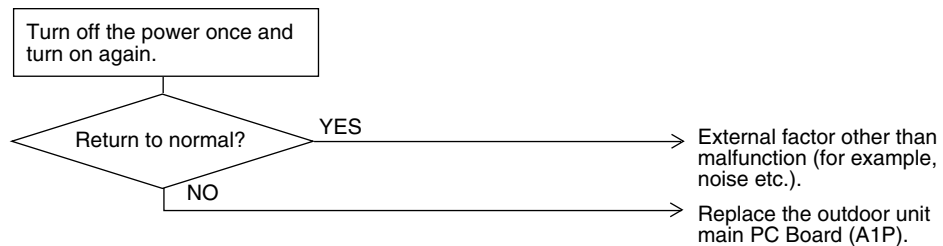

(V3064)

## 2.14 “E3” Outdoor Unit: Actuation of High Pressure Switch

Remote Controller Display

E3

Applicable Models

RXYQ72M, 96M

Method of Malfunction Detection

Abnormality is detected when the contact of the high pressure protection switch opens.

Malfunction Decision Conditions

Error is generated when the HPS activation count reaches the number specific to the operation mode.

Supposed Causes

- Actuation of outdoor unit high pressure switch
- Defect of High pressure switch
- Defect of outdoor unit PC board
- Instantaneous power failure
- Faulty high pressure sensor

### Troubleshooting



**Caution**

Be sure to turn off power switch before connect or disconnect connector, or parts damage may be occurred.

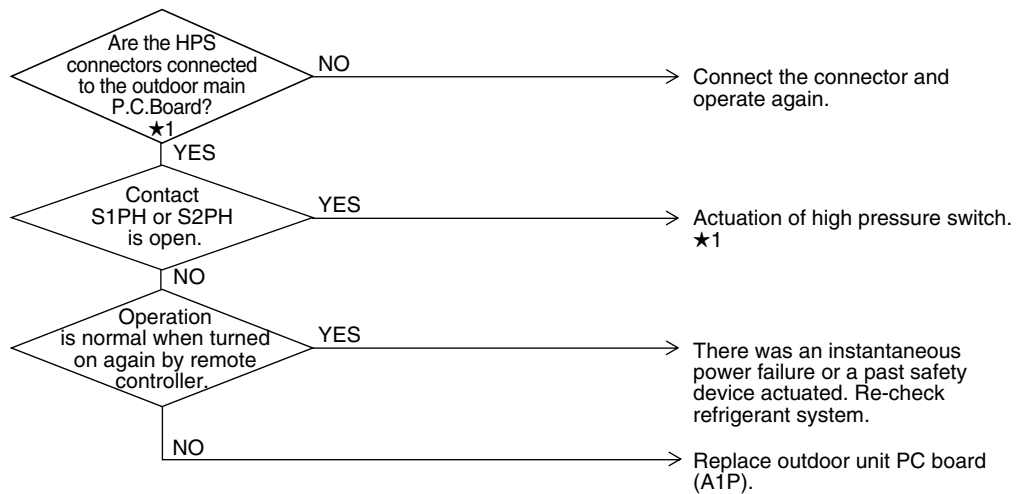

(V3065)

- ★1: Actuation of high pressure switch (HPS)
- The outdoor unit PC board’s connector is disconnected.
  - Is the outdoor unit heat exchanger dirty?
  - Defect of outdoor fan
  - Is the refrigerant over-charged?
  - Faulty high pressure sensor

## 2.15 “E4” Outdoor Unit: Actuation of Low Pressure Sensor

Remote  
Controller  
Display

E4

Applicable  
Models

RXYQ72M, 96M

Method of  
Malfunction  
Detection

Abnormality is detected by the pressure value with the low pressure sensor.

Malfunction  
Decision  
Conditions

Error is generated when the low pressure is dropped under specific pressure.

Supposed  
Causes

- Abnormal drop of low pressure (Lower than 21psi)
- Defect of low pressure sensor
- Defect of outdoor unit PC board
- Stop valve is not opened.

Troubleshooting



**Caution**

Be sure to turn off power switch before connect or disconnect connector, or parts damage may be occurred.

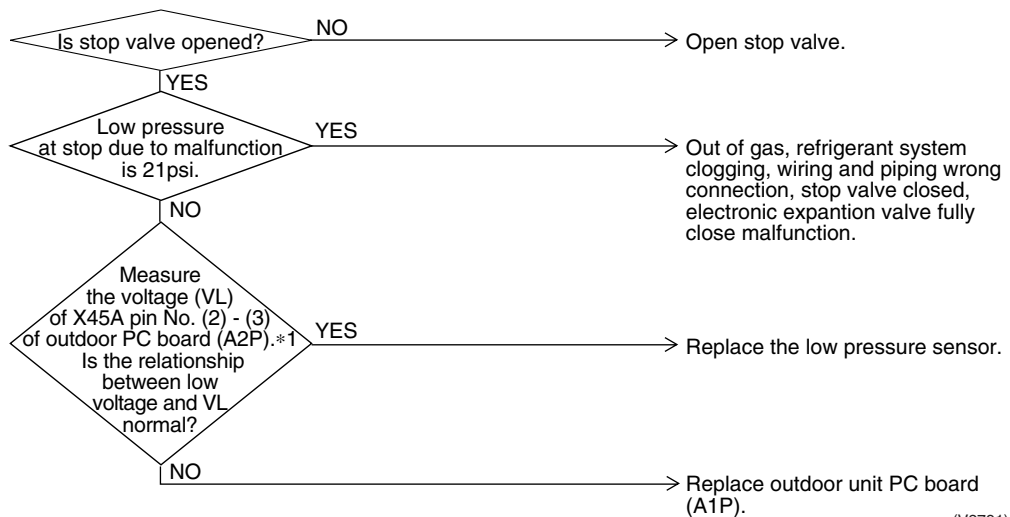

(V2791)

\*1: Voltage measurement point

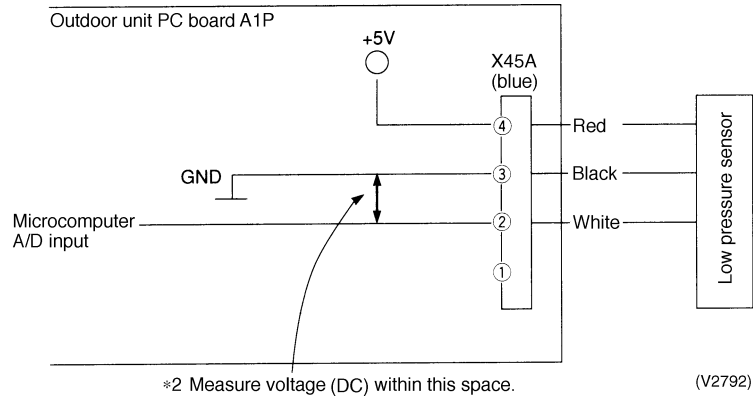

\*1: Refer to pressure sensor, pressure / voltage characteristics table on P241.

## 2.16 “E5” Compressor Motor Lock

Remote  
Controller  
Display

E5

Applicable  
Models

RXYQ72M, 96M

Method of  
Malfunction  
Detection

Inverter PC board takes the position signal from UVWN line connected between the inverter and compressor, and detects the position signal pattern.

Malfunction  
Decision  
Conditions

The position signal with 3 times cycle as imposed frequency is detected when compressor motor operates normally, but 2 times cycle when compressor motor locks. When the position signal in 2 times cycle is detected.

Supposed  
Causes

- Compressor lock
- High differential pressure (72psi or more)
- Incorrect UVWN wiring
- Faulty inverter PC board
- Stop valve is left in closed.

Troubleshooting



**Caution**

Be sure to turn off power switch before connect or disconnect connector, or parts damage may be occurred.

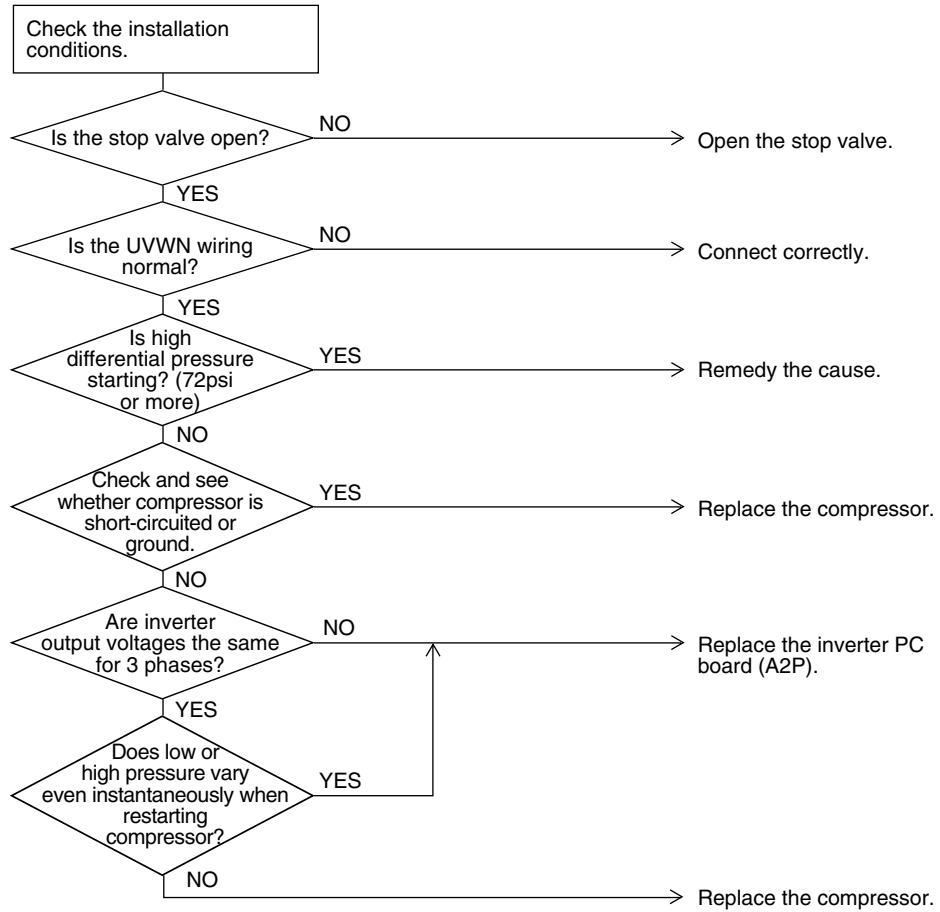

(V2793)

## 2.17 “E6” Compressor Motor Overcurrent/Lock

|  |  |
|--|--|
| <b>Remote Controller Display</b>       | E6   |
| <b>Applicable Models</b>               | RXYQ72M, 96M   |
| <b>Method of Malfunction Detection</b> | Detects the overcurrent with current sensor (CT).  |
| <b>Malfunction Decision Conditions</b> | Malfunction is decided when the detected current value exceeds the below mentioned value for 2 seconds.<br><ul style="list-style-type: none"> <li>■ 200V unit : 28.8A</li> </ul>   |
| <b>Supposed Causes</b>                 | <ul style="list-style-type: none"> <li>■ Closed stop valve</li> <li>■ Obstacles at the discharge port</li> <li>■ Improper power voltage</li> <li>■ Faulty magnetic switch</li> <li>■ Faulty compressor</li> <li>■ Faulty current sensor (A5P)</li> </ul> |

### Troubleshooting



**Caution**

Be sure to turn off power switch before connect or disconnect connector, or parts damage may be occurred.

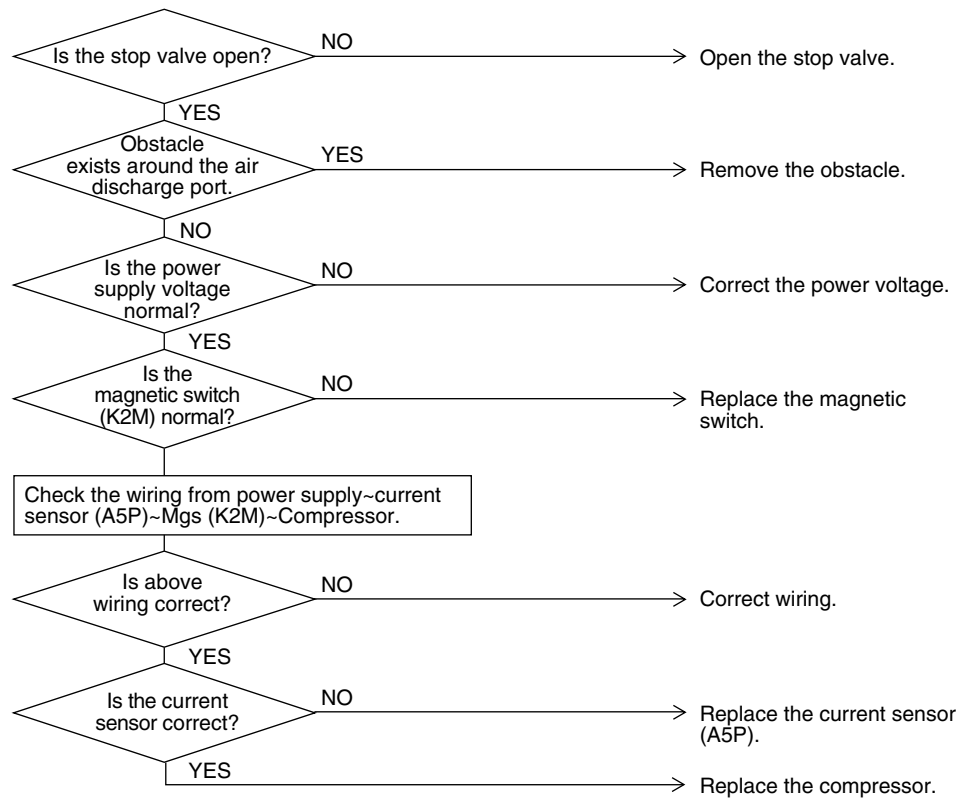

(V3051)



## 2.18 “E7” Malfunction of Outdoor Unit Fan Motor

Remote Controller Display

E7

Applicable Models

RXYQ72M, 96M

Method of Malfunction Detection

Malfunction of fan motor system is detected according to the fan speed detected by hall IC when the fan motor runs.

Malfunction Decision Conditions

- When the fan runs with speed less than a specified one for 15 seconds or more when the fan motor running conditions are met
- When connector detecting fan speed is disconnected
- When malfunction is generated 4 times, the system shuts down.

Supposed Causes

- Malfunction of fan motor
- The harness connector between fan motor and PC board is left in disconnected, or faulty connector
- Fan does not run due to foreign matters tangled
- Clearing condition: Operate for 5 minutes (normal)

### Troubleshooting



**Caution**

Be sure to turn off power switch before connect or disconnect connector, or parts damage may be occurred.

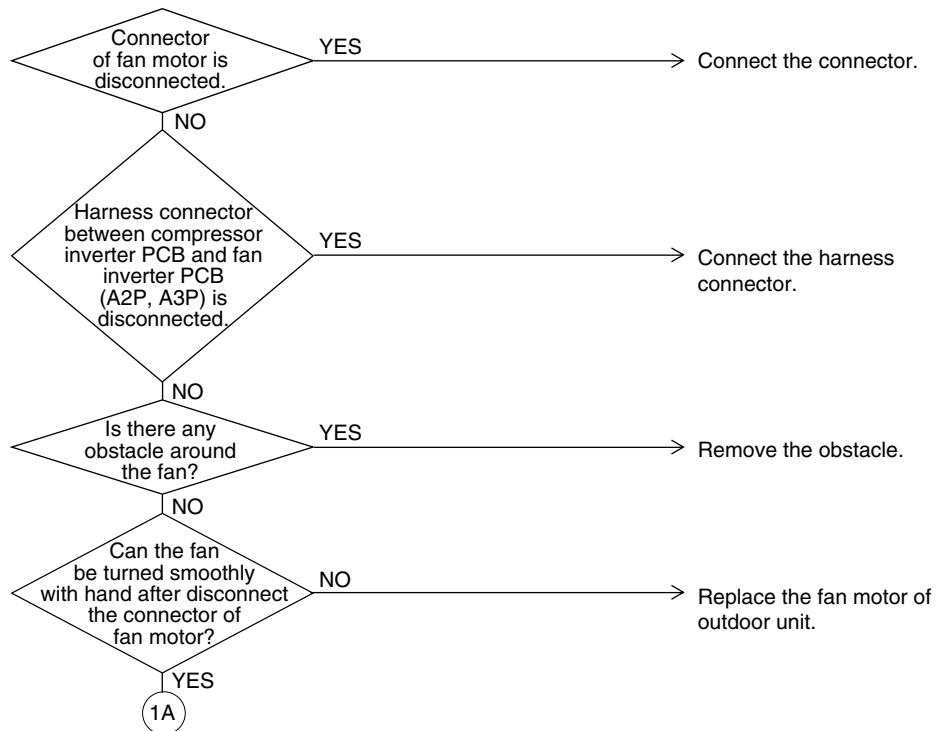

(V3076)

## Troubleshooting

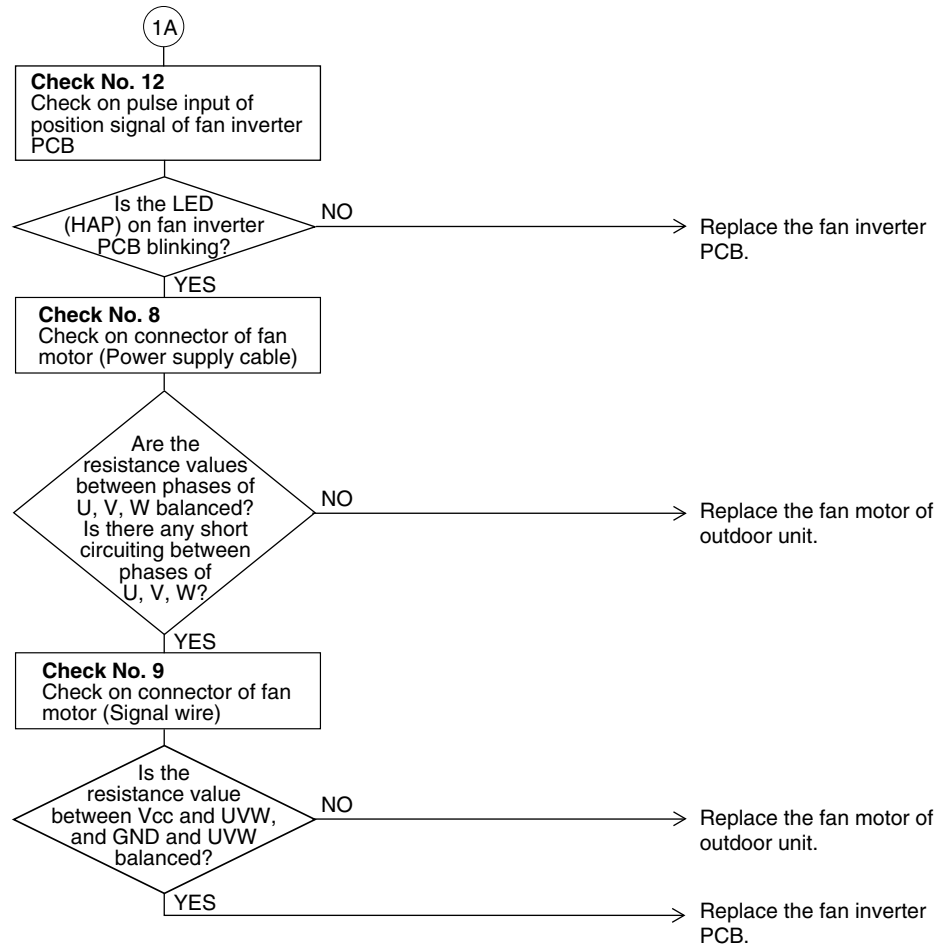

(V3077)



**Note:** Refer check 8, 9 and 12 to P.214~215.

## 2.19 “E9” Outdoor Unit: Malfunction of Moving Part of Electronic Expansion Valve (Y1E, Y2E)

|                                 |  |
|---------------------------------|--|
| Remote Controller Display       | E9   |
| Applicable Models               | RXYQ72M, 96M   |
| Method of Malfunction Detection | Check disconnection of connector<br>Check continuity of expansion valve coil   |
| Malfunction Decision Conditions | Error is generated under no common power supply when the power is on.  |
| Supposed Causes                 | <ul style="list-style-type: none"> <li>■ Defect of moving part of electronic expansion valve</li> <li>■ Defect of outdoor unit PC board (A1P)</li> <li>■ Defect of connecting cable</li> </ul> |

### Troubleshooting

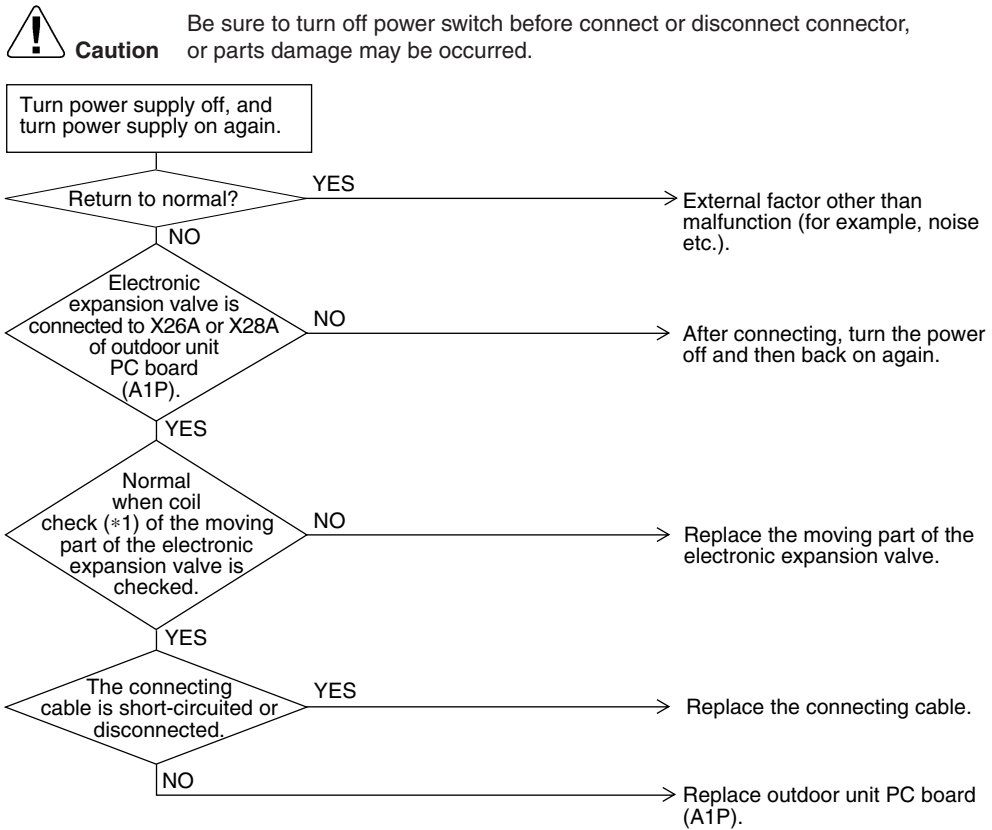

(V3067)

\*1 Coil check method for the moving part of the electronic expansion valve

Disconnect the electronic expansion valve from the PC board and check the continuity between the connector pins.

(Normal)

| Pin No.   | 1. White | 2. Yellow | 3. Orange            | 4. Blue              | 5. Red               | 6. Brown             |
|-----------|----------|-----------|----------------------|----------------------|----------------------|----------------------|
| 1. White  |          | x         | ⊙<br>Approx.<br>300Ω | x                    | ○<br>Approx.<br>150Ω | x                    |
| 2. Yellow |          |           | x                    | ⊙<br>Approx.<br>300Ω | x                    | ○<br>Approx.<br>150Ω |
| 3. Orange |          |           |                      | x                    | ○<br>Approx.<br>150Ω | x                    |
| 4. Blue   |          |           |                      |                      | x                    | ○<br>Approx.<br>150Ω |
| 5. Red    |          |           |                      |                      |                      | x                    |
| 6. Brown  |          |           |                      |                      |                      |                      |

⊙ : Continuity Approx. 300Ω

○ : Continuity Approx. 150Ω

x : No continuity

## 2.20 “F3” Outdoor Unit: Abnormal Discharge Pipe Temperature

|  |  |
|--|--|
| <b>Remote Controller Display</b>       | <b>F3</b>  |
| <b>Applicable Models</b>               | RXYQ72M, 96M   |
| <b>Method of Malfunction Detection</b> | Abnormality is detected according to the temperature detected by the discharge pipe temperature sensor.  |
| <b>Malfunction Decision Conditions</b> | <ul style="list-style-type: none"> <li>■ When the discharge pipe temperature rises to an abnormally high level</li> <li>■ When the discharge pipe temperature rises suddenly</li> </ul>                |
| <b>Supposed Causes</b>                 | <ul style="list-style-type: none"> <li>■ Faulty discharge pipe temperature sensor</li> <li>■ Faulty connection of discharge pipe temperature sensor</li> <li>■ Faulty outdoor unit PC board</li> </ul> |

### Troubleshooting



**Caution**

Be sure to turn off power switch before connect or disconnect connector, or parts damage may be occurred.

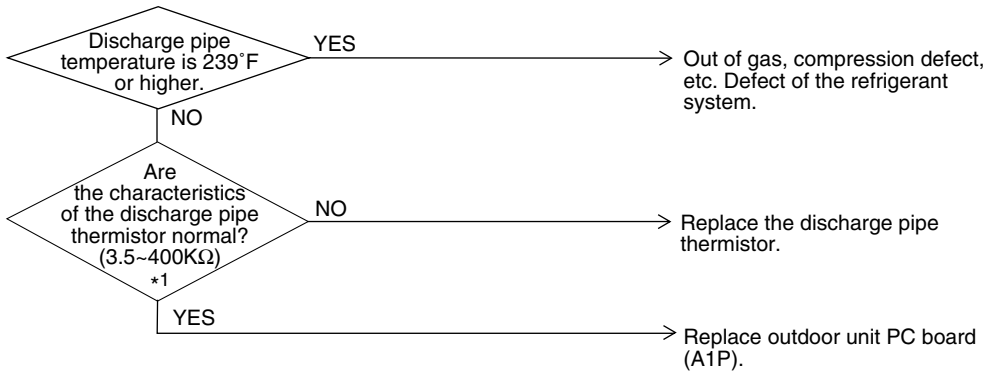

(V3068)



\*1: Refer to thermistor resistance / temperature characteristics table on P239.

## 2.21 “F6” Refrigerant Overcharged

Remote  
Controller  
Display

F6

Applicable  
Models

RXYQ72M, 96M

Method of  
Malfunction  
Detection

Refrigerant overcharge is detected from the receiver gas pipe temperature during test operation.

Malfunction  
Decision  
Conditions

When the receiver gas pipe temperature is lower than evaporating temperature during test operation.

Supposed  
Causes

- Refrigerant overcharge
- Disconnection of the receiver gas pipe thermistor

Troubleshooting



**Caution**

Be sure to turn off power switch before connect or disconnect connector, or parts damage may be occurred.

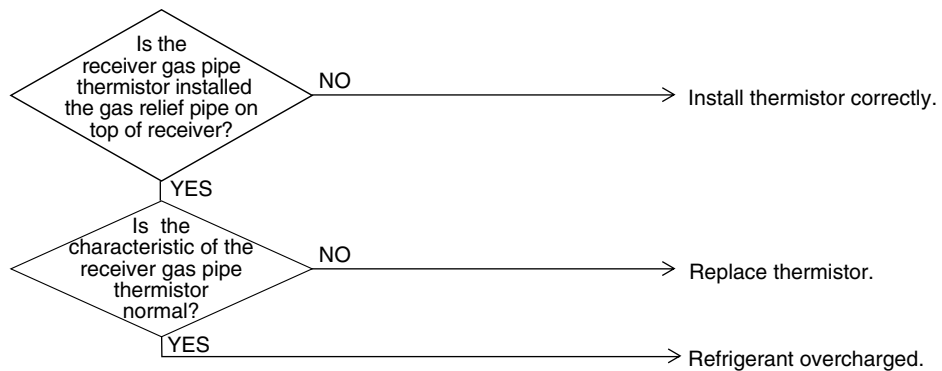

(V2797)

## 2.22 “H7” Abnormal Outdoor Fan Motor Signal

|                                 |  |
|---------------------------------|--|
| Remote Controller Display       | H7   |
| Applicable Models               | RXYQ72M, 96M   |
| Method of Malfunction Detection | Detection of abnormal signal from fan motor.   |
| Malfunction Decision Conditions | In case of detection of abnormal signal at starting fan motor.   |
| Supposed Causes                 | <ul style="list-style-type: none"> <li>■ Abnormal fan motor signal (circuit malfunction)</li> <li>■ Broken, short or disconnection connector of fan motor connection cable</li> <li>■ Fan Inverter PC board malfunction</li> </ul> |

### Troubleshooting

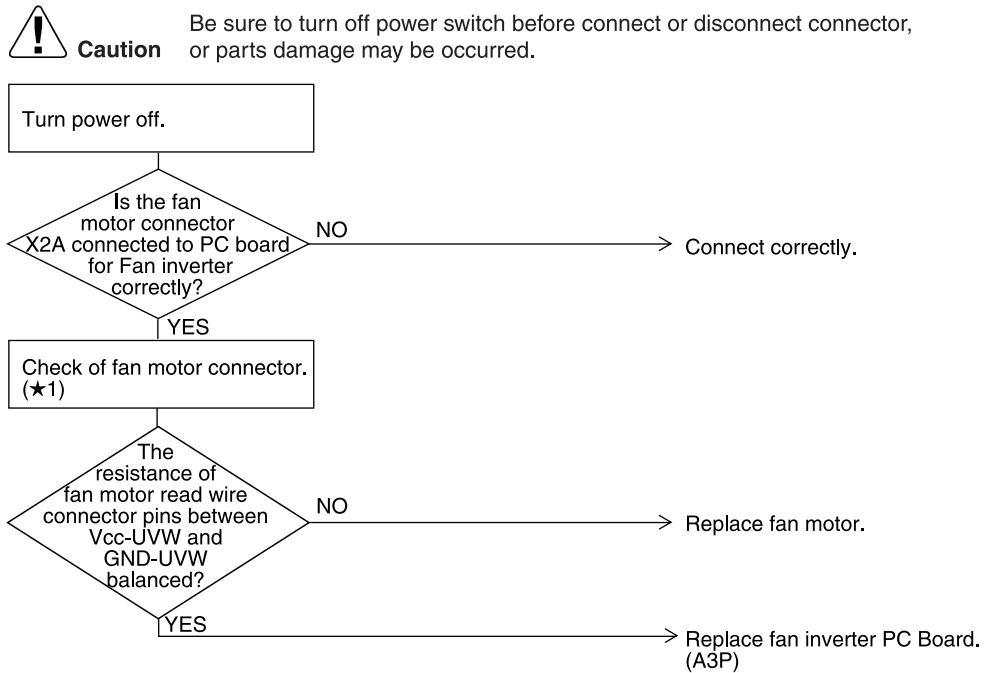

(V3069)

★1: Disconnect connector (X2A) and measure the following resistance.

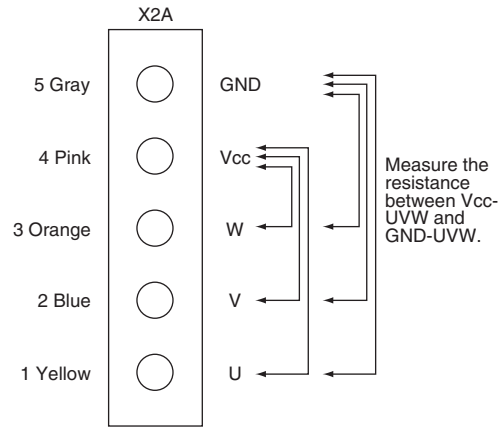

(V2799)



## 2.23 “H9” Outdoor Unit: Malfunction of Thermistor (R1T) for Outdoor Air

|                                 |   |
|---------------------------------|---|
| Remote Controller Display       | H9  |
| Applicable Models               | RXYQ72M, 96M  |
| Method of Malfunction Detection | The abnormal detection is based on current detected by current sensor.  |
| Malfunction Decision Conditions | When the outside air temperature sensor has short circuit or open circuit.  |
| Supposed Causes                 | <ul style="list-style-type: none"> <li>■ Defect of thermistor (R1T) for outdoor air</li> <li>■ Defect of outdoor unit PC board (A1P)</li> </ul> |

### Troubleshooting



**Caution**

Be sure to turn off power switch before connect or disconnect connector, or parts damage may be occurred.

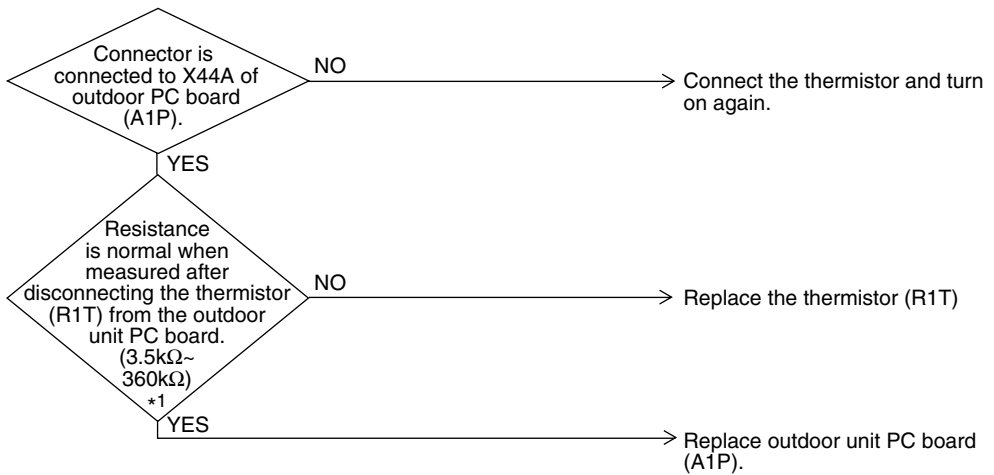

(V3070)

The alarm indicator is displayed when the fan only is being used also.



\*1: Refer to thermistor resistance / temperature characteristics table on P239.

## 2.24 “J2” Current Sensor Malfunction

Remote  
Controller  
Display

J2

Applicable  
Models

RXYQ72M, 96M

Method of  
Malfunction  
Detection

Malfunction is detected according to the current value detected by current sensor.

Malfunction  
Decision  
Conditions

When the current value detected by current sensor becomes 5A or lower, or 40A or more during standard compressor operation.

Supposed  
Causes

- Faulty current sensor
- Faulty outdoor unit PC board

Troubleshooting



**Caution**

Be sure to turn off power switch before connect or disconnect connector, or parts damage may be occurred.

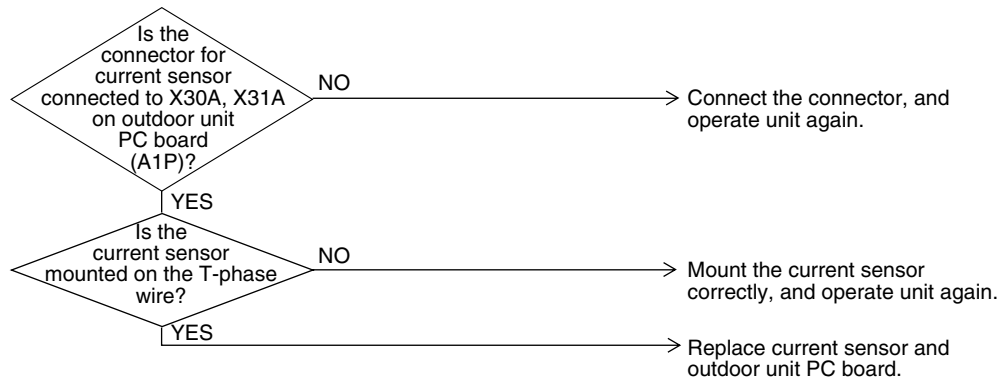

(V3071)

## 2.25 “J3” Outdoor Unit: Malfunction of Discharge Pipe Thermistor (R31~33T)

|  |  |
|--|--|
| <b>Remote Controller Display</b>       | J3   |
| <b>Applicable Models</b>               | RXYQ72M, 96M   |
| <b>Method of Malfunction Detection</b> | Malfunction is detected from the temperature detected by discharge pipe temperature thermistor.  |
| <b>Malfunction Decision Conditions</b> | When a short circuit or an open circuit in the discharge pipe temperature thermistor is detected.  |
| <b>Supposed Causes</b>                 | <ul style="list-style-type: none"> <li>■ Defect of thermistor (R31T, R32T) for outdoor unit discharge pipe</li> <li>■ Defect of outdoor unit PC board (A1P)</li> </ul> |

### Troubleshooting



**Caution**

Be sure to turn off power switch before connect or disconnect connector, or parts damage may be occurred.

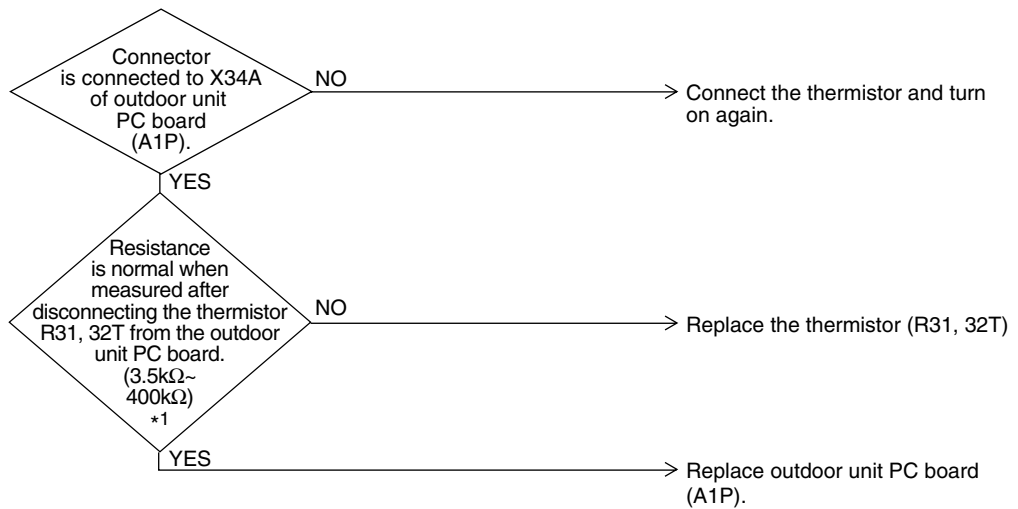

(V3072)

The alarm indicator is displayed when the fan is being used also.



\*1: Refer to thermistor resistance / temperature characteristics table on P240.

## 2.26 “J5” Outdoor Unit: Malfunction of Thermistor (R2T) for Suction Pipe

Remote Controller Display

J5

Applicable Models

RXYQ72M, 96M

Method of Malfunction Detection

Malfunction is detected from the temperature detected by the suction pipe temperature thermistor.

Malfunction Decision Conditions

When a short circuit or an open circuit in the suction pipe temperature thermistor is detected.

Supposed Causes

- Defect of thermistor (R2T) for outdoor unit suction pipe
- Defect of outdoor unit PC board (A1P)

Troubleshooting



**Caution**

Be sure to turn off power switch before connect or disconnect connector, or parts damage may be occurred.

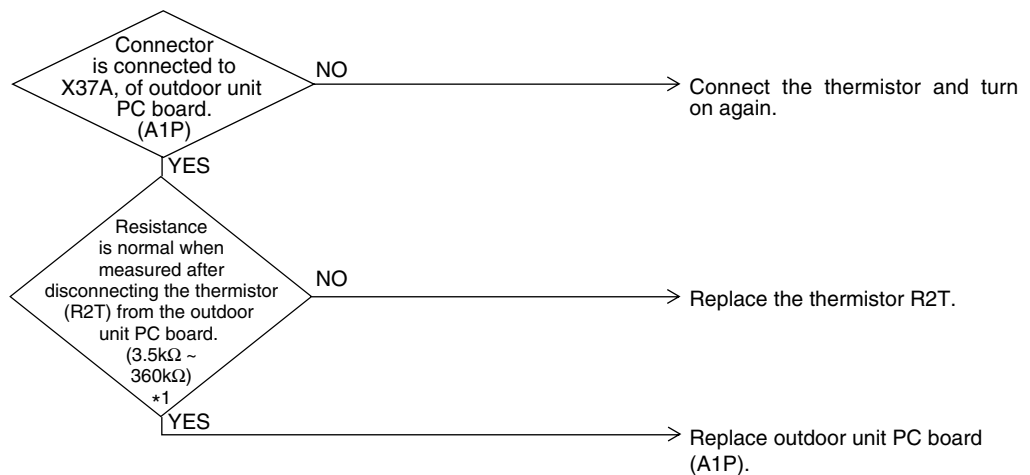

(V3073)



\*1: Refer to thermistor resistance / temperature characteristics table on P239.

## 2.27 “J6” Outdoor Unit: Malfunction of Thermistor (R4T) for Outdoor Unit Heat Exchanger Deicer

|                                 |   |
|---------------------------------|---|
| Remote Controller Display       | J6  |
| Applicable Models               | RXYQ72M, 96M  |
| Method of Malfunction Detection | Malfunction is detected from the temperature detected by the heat exchanger thermistor.   |
| Malfunction Decision Conditions | When a short circuit or an open circuit in the heat exchange thermistor is detected.  |
| Supposed Causes                 | <ul style="list-style-type: none"> <li>■ Defect of thermistor (R4T) for outdoor unit coil</li> <li>■ Defect of outdoor unit PC board (A1P)</li> </ul> |

### Troubleshooting



**Caution**

Be sure to turn off power switch before connect or disconnect connector, or parts damage may be occurred.

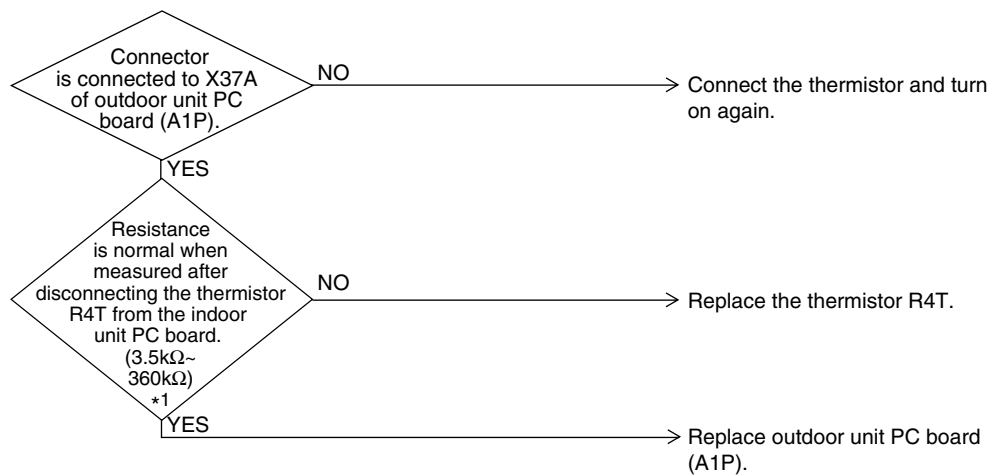

(V3074)



\*1: Refer to thermistor resistance / temperature characteristics table on P239.

## 2.28 “J7” Malfunction of Receiver Outlet Liquid Pipe Thermistor (R6T)

|                                 |   |
|---------------------------------|---|
| Remote Controller Display       | J7  |
| Applicable Models               | RXYQ72M, 96M  |
| Method of Malfunction Detection | Malfunction is detected according to the temperature detected by receiver outlet liquid pipe thermistor.  |
| Malfunction Decision Conditions | When the receiver outlet liquid pipe thermistor is short circuited or open.   |
| Supposed Causes                 | <ul style="list-style-type: none"> <li>■ Faulty receiver outlet liquid pipe thermistor (R6T)</li> <li>■ Faulty outdoor unit PC board</li> </ul> |
| Troubleshooting                 |   |

**Caution**

Be sure to turn off power switch before connect or disconnect connector, or parts damage may be occurred.

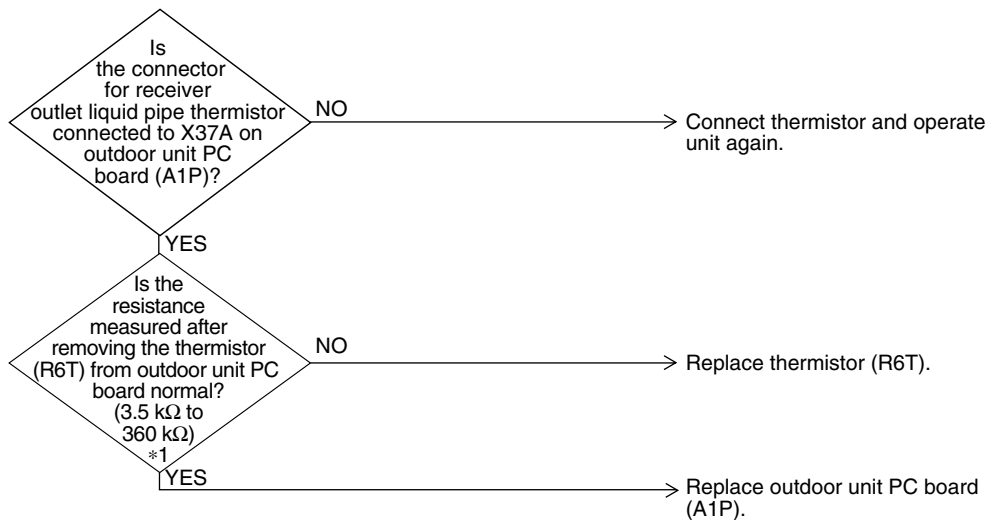

(V3075)



\*1: Refer to thermistor resistance / temperature characteristics table on P239.

## 2.29 “JB” Malfunction of Oil Equalizing Pipe Thermistor (R7T)

|                                 |   |
|---------------------------------|---|
| Remote Controller Display       | JB  |
| Applicable Models               | RXYQ72M, 96M  |
| Method of Malfunction Detection | Malfunction is detected according to the temperature detected by oil equalizing pipe thermistor.  |
| Malfunction Decision Conditions | When the oil equalizing pipe thermistor is short circuited or open.   |
| Supposed Causes                 | <ul style="list-style-type: none"> <li>■ Faulty oil equalizing pipe thermistor (R7T)</li> <li>■ Faulty outdoor unit PC board</li> </ul> |

### Troubleshooting



**Caution**

Be sure to turn off power switch before connect or disconnect connector, or parts damage may be occurred.

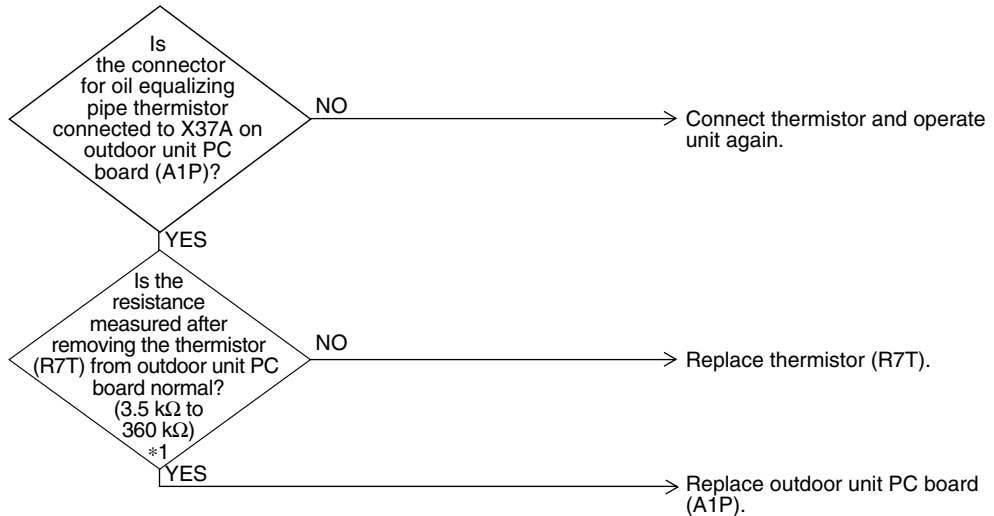

(V3075)



\*1: Refer to thermistor resistance / temperature characteristics table on P239.

## 2.30 “J9” Malfunction of Sub-Cooling Gas Pipe Thermistor (R5T)

Remote  
Controller  
Display

J9

Applicable  
Models

RXYQ72M, 96M

Method of  
Malfunction  
Detection

Malfunction is detected according to the temperature detected by Sub Cooling gas pipe thermistor.

Malfunction  
Decision  
Conditions

When the Sub Cooling gas pipe thermistor is short circuited or open.

Supposed  
Causes

- Faulty Sub Cooling gas pipe thermistor (R5T)
- Faulty outdoor unit PC board

Troubleshooting



**Caution**

Be sure to turn off power switch before connect or disconnect connector, or parts damage may be occurred.

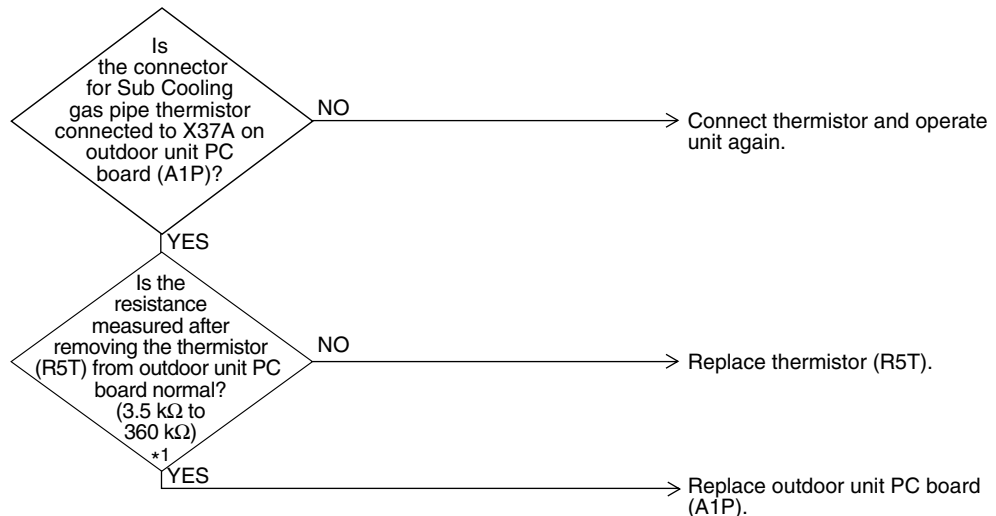

(V3075)



\*1: Refer to thermistor resistance / temperature characteristics table on P239.



## 2.31 “JA” Outdoor Unit: Malfunction of Discharge Pipe Pressure Sensor

|                                 |   |
|---------------------------------|---|
| Remote Controller Display       | JA  |
| Applicable Models               | RXYQ72M, 96M  |
| Method of Malfunction Detection | Malfunction is detected from the pressure detected by the high pressure sensor.   |
| Malfunction Decision Conditions | When the discharge pipe pressure sensor is short circuit or open circuit.   |
| Supposed Causes                 | <ul style="list-style-type: none"> <li>■ Defect of high pressure sensor system</li> <li>■ Connection of low pressure sensor with wrong connection.</li> <li>■ Defect of outdoor unit PC board.</li> </ul> |

### Troubleshooting



**Caution**

Be sure to turn off power switch before connect or disconnect connector, or parts damage may be occurred.

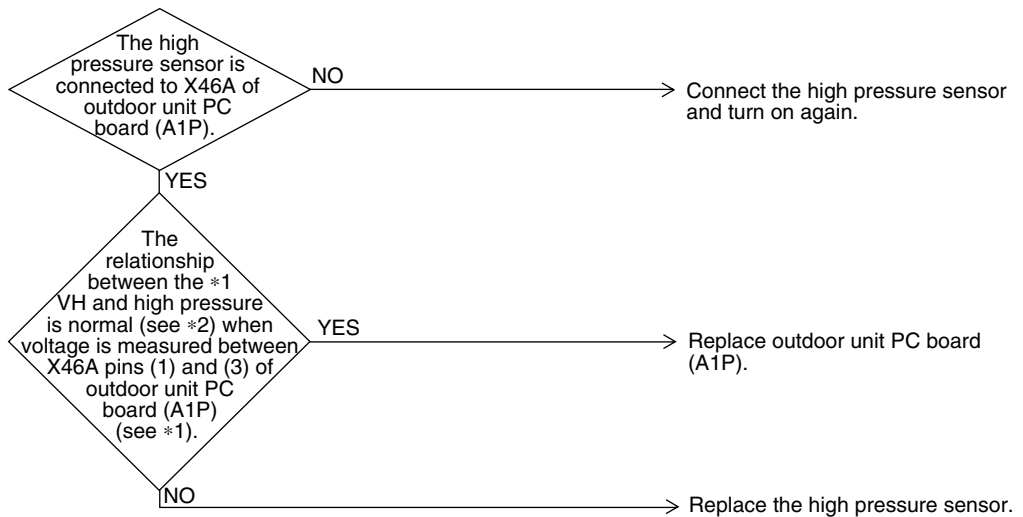

(V2806)

\*1: Voltage measurement point

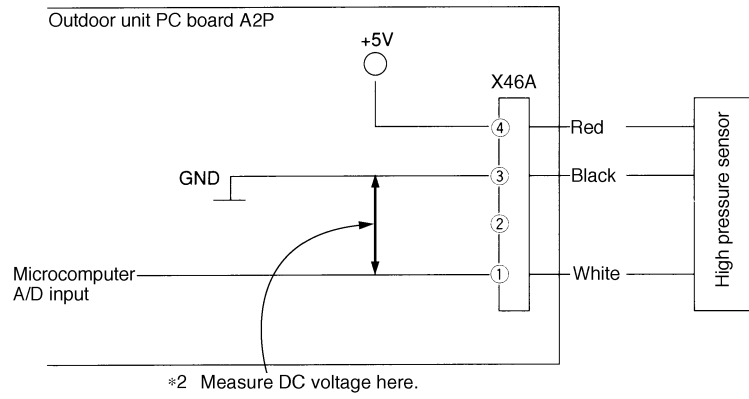

(V2807)



\*2: Refer to pressure sensor, pressure / voltage characteristics table on P241.

## 2.32 “JC” Outdoor Unit: Malfunction of Suction Pipe Pressure Sensor

Remote Controller Display



Applicable Models

RXYQ72M, 96M

Method of Malfunction Detection

Malfunction is detected from pressure detected by low pressure sensor.

Malfunction Decision Conditions

When the suction pipe pressure sensor is short circuit or open circuit.

Supposed Causes

- Defect of low pressure sensor system
- Connection of high pressure sensor with wrong connection.
- Defect of outdoor unit PC board.

### Troubleshooting



**Caution**

Be sure to turn off power switch before connect or disconnect connector, or parts damage may be occurred.

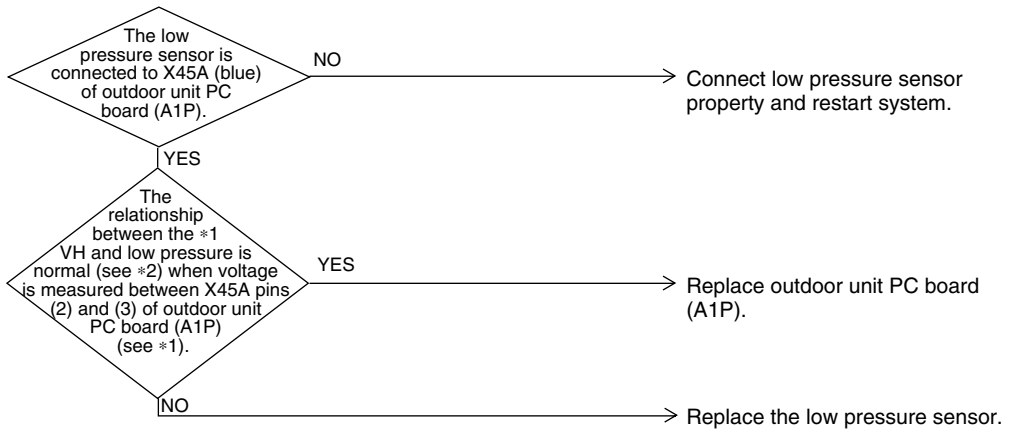

(V2808)

\*1: Voltage measurement point

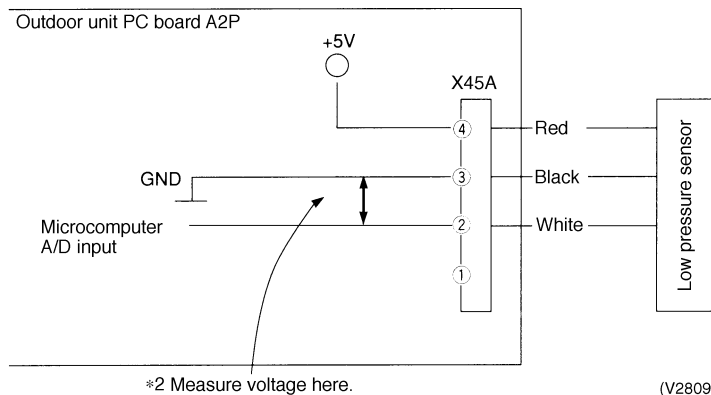

(V2809)



\*2: Refer to pressure sensor, pressure/voltage characteristics table on P241.

## 2.33 “L4” Outdoor Unit: Malfunction of Inverter Radiating Fin Temperature Rise

|                                 |  |
|---------------------------------|--|
| Remote Controller Display       | L4   |
| Applicable Models               | RXYQ72M, 96M   |
| Method of Malfunction Detection | Fin temperature is detected by the thermistor of the radiation fin.  |
| Malfunction Decision Conditions | When the temperature of the inverter radiation fin increases above 192°F.  |
| Supposed Causes                 | <ul style="list-style-type: none"> <li>■ Actuation of fin thermal (Actuates above 192°F)</li> <li>■ Defect of inverter PC board</li> <li>■ Defect of fin thermistor</li> </ul> |

### Troubleshooting

**Caution**

Be sure to turn off power switch before connect or disconnect connector, or parts damage may be occurred.

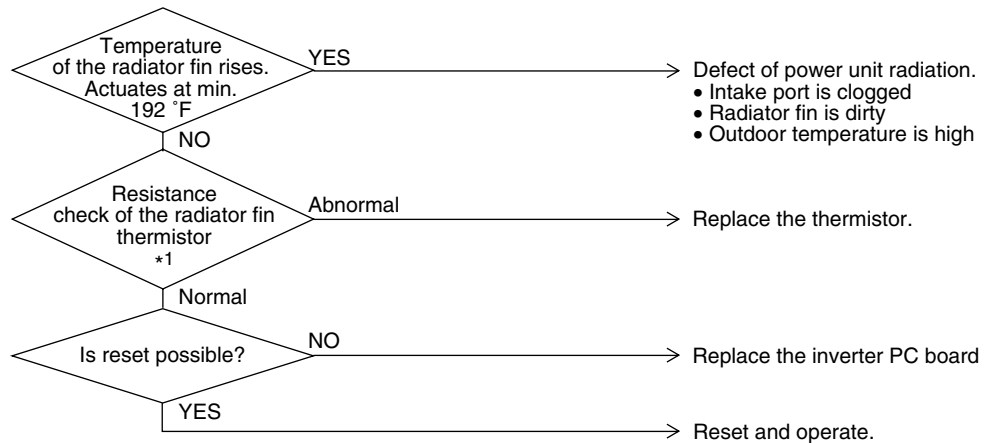

(V2811)



\*1: Refer to thermistor resistance / temperature characteristics table on P239.

## 2.34 “L5” Outdoor Unit: Inverter Compressor Abnormal

|  |  |
|--|--|
| <b>Remote Controller Display</b>       | L5   |
| <b>Applicable Models</b>               | RXYQ72M, 96M   |
| <b>Method of Malfunction Detection</b> | Malfunction is detected from current flowing in the power transistor.  |
| <b>Malfunction Decision Conditions</b> | When an excessive current flows in the power transistor.<br>(Instantaneous overcurrent also causes activation.)  |
| <b>Supposed Causes</b>                 | <ul style="list-style-type: none"> <li>■ Defect of compressor coil (disconnected, defective insulation)</li> <li>■ Compressor start-up malfunction (mechanical lock)</li> <li>■ Defect of inverter PC board</li> </ul> |
| <b>Troubleshooting</b>                 | Compressor inspection  |



**Caution**

Be sure to turn off power switch before connect or disconnect connector, or parts damage may be occurred.

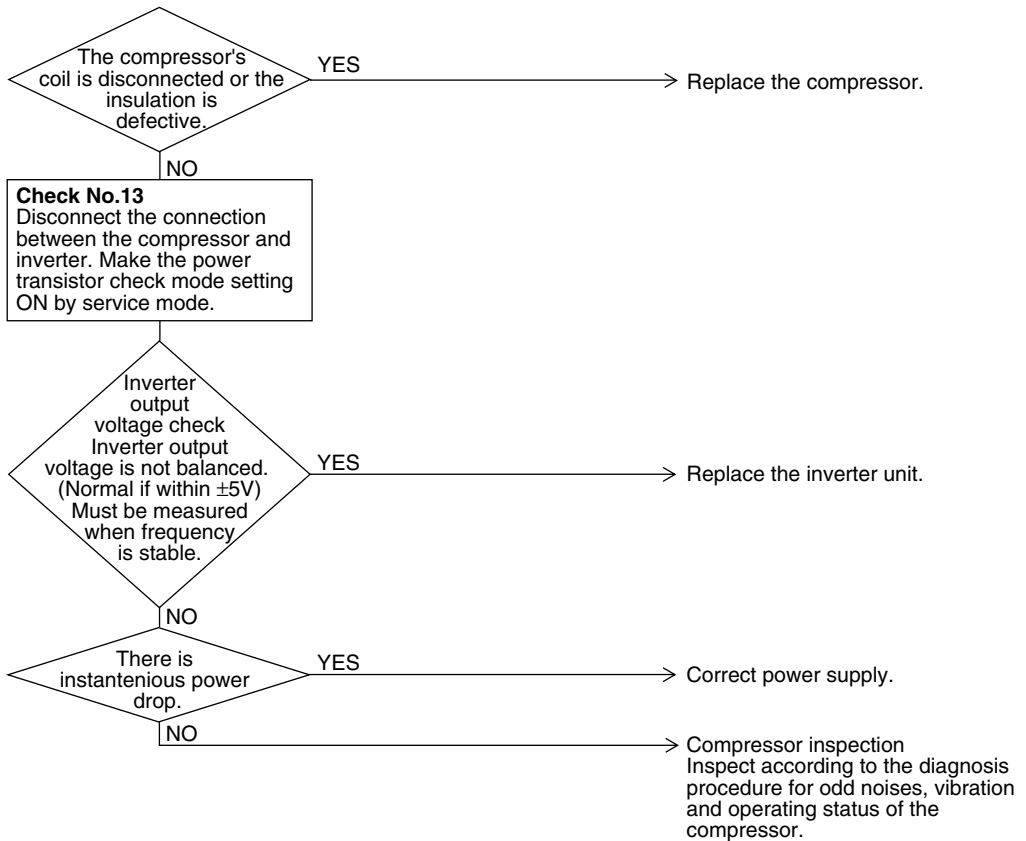

(V2812)

Higher voltage than actual is displayed when the inverter output voltage is checked by tester.

## 2.35 “LB” Outdoor Unit: Inverter Current Abnormal

Remote  
Controller  
Display

LB

Applicable  
Models

RXYQ72M, 96M

Method of  
Malfunction  
Detection

Malfunction is detected by current flowing in the power transistor.

Malfunction  
Decision  
Conditions

When overload in the compressor is detected.

Supposed  
Causes

- Compressor overload
- Compressor coil disconnected
- Defect of inverter PC board

Troubleshooting Output current check



**Caution** Be sure to turn off power switch before connect or disconnect connector, or parts damage may be occurred.

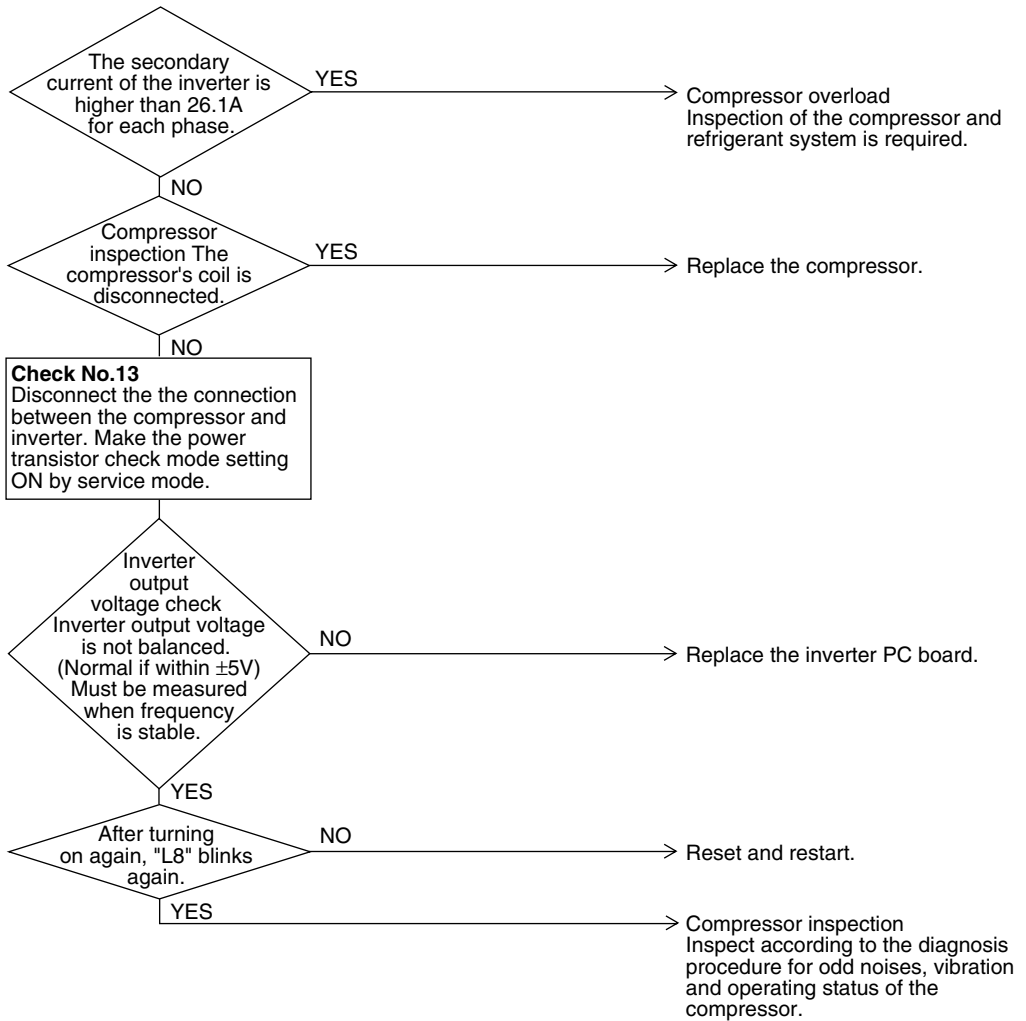

(V2813)

## 2.36 “L9” Outdoor Unit: Inverter Start up Error

Remote  
Controller  
Display

L9

Applicable  
Models

RXYQ72M, 96M

Method of  
Malfunction  
Detection

Malfunction is detected from current flowing in the power transistor.

Malfunction  
Decision  
Conditions

When overload in the compressor is detected during startup

Supposed  
Causes

- Defect of compressor
- Pressure differential start
- Defect of inverter PC board

### Troubleshooting



**Caution**

Be sure to turn off power switch before connect or disconnect connector, or parts damage may be occurred.

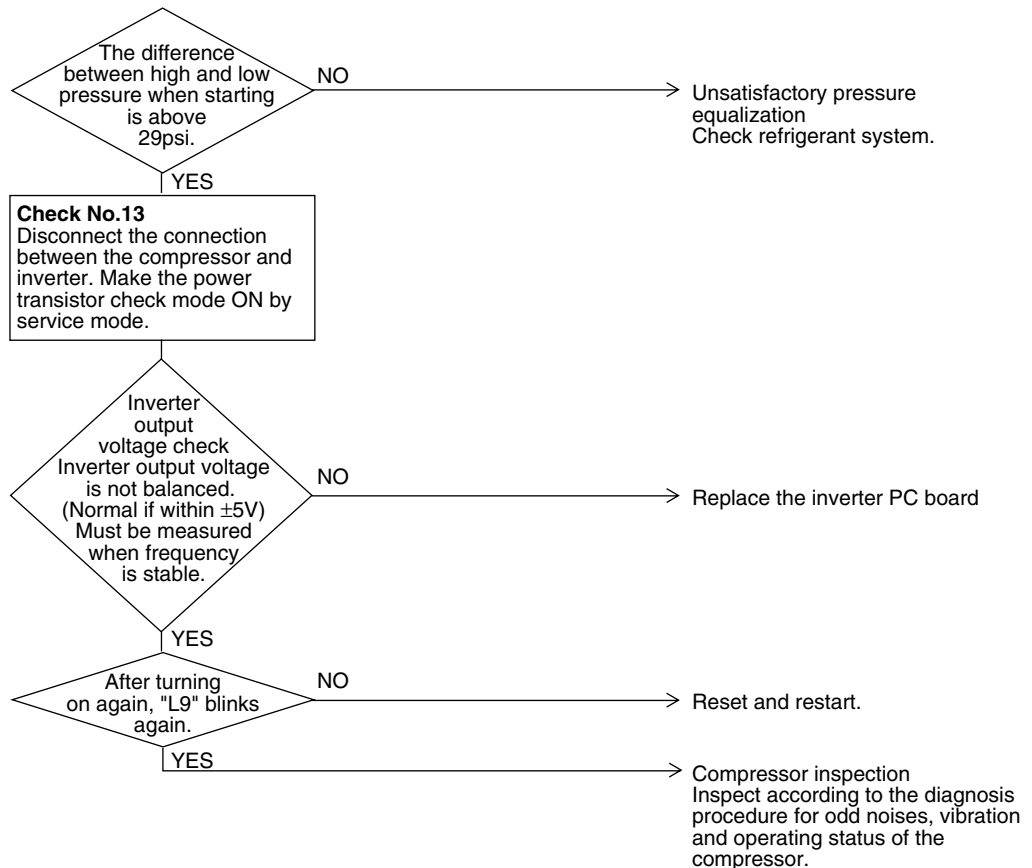

(V2814)



## 2.37 “LC” Outdoor Unit: Malfunction of Transmission Between Inverter and Control PC Board

|   |  |
|---|--|
| <p><b>Remote Controller Display</b></p>       | <p>LC</p>  |
| <p><b>Applicable Models</b></p>               | <p>RXYQ72M, 96M</p>  |
| <p><b>Method of Malfunction Detection</b></p> | <p>Check the communication state between inverter PC board and control PC board by micro-computer.</p>   |
| <p><b>Malfunction Decision Conditions</b></p> | <p>When the correct communication is not conducted in certain period.</p>  |
| <p><b>Supposed Causes</b></p>                 | <ul style="list-style-type: none"> <li>■ Malfunction of connection between the inverter PC board and outdoor control PC board</li> <li>■ Defect of outdoor control PC board (transmission section)</li> <li>■ Defect of inverter PC board</li> <li>■ Defect of noise filter</li> <li>■ External factor (Noise etc.)</li> </ul> |

## Troubleshooting



**Caution** Be sure to turn off power switch before connect or disconnect connector, or parts damage may be occurred.

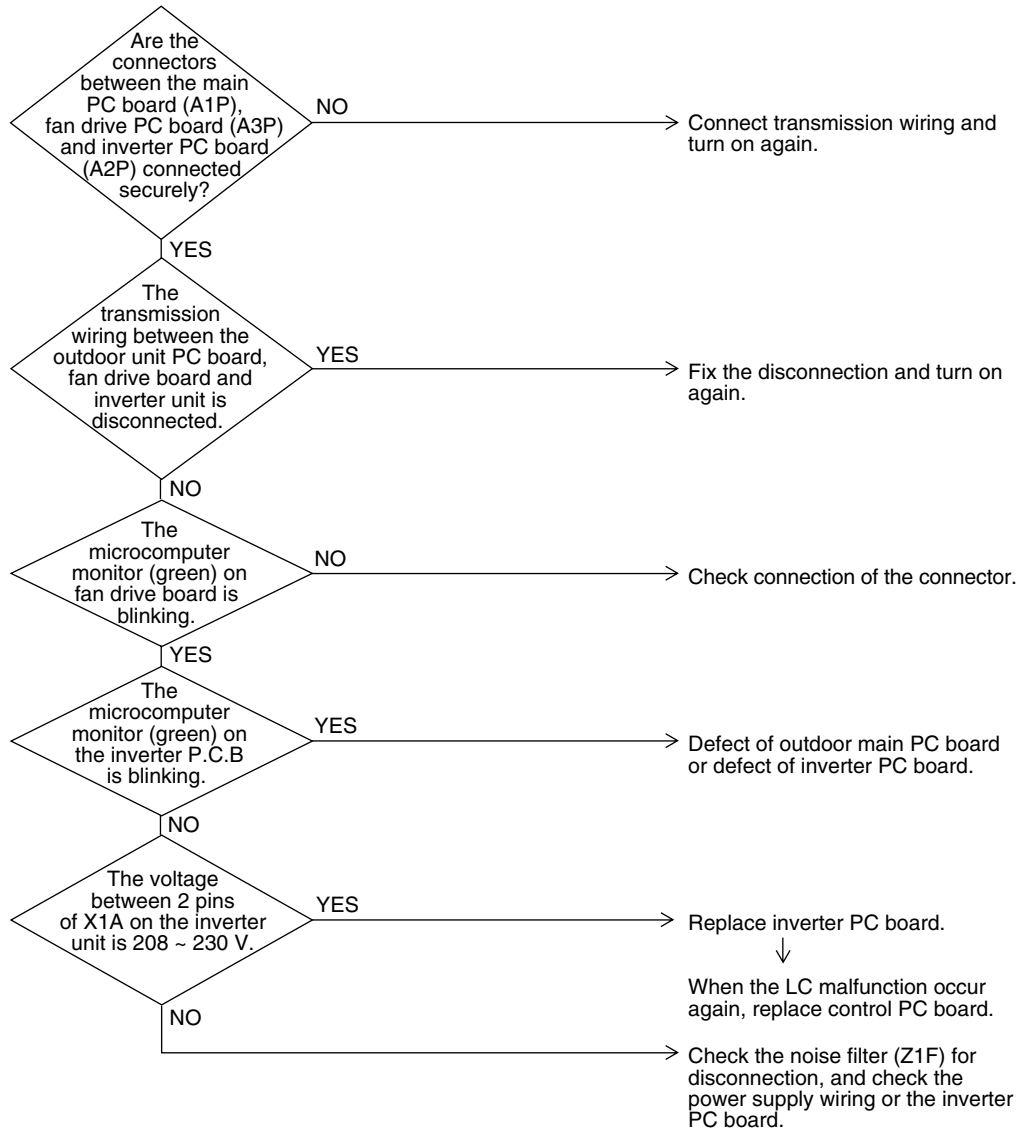

(V2815)

## 2.38 “P1” Outdoor Unit: Inverter Over-Ripple Protection

Remote  
Controller  
Display

P1

Applicable  
Models

RXYQ72M, 96M

Method of  
Malfunction  
Detection

Imbalance in supply voltage is detected in PC board.

Malfunction  
Decision  
Conditions

When the resistance value of thermistor becomes a value equivalent to open or short circuited status.

- Malfunction is not decided while the unit operation is continued.  
"P1" will be displayed by pressing the inspection button.

Supposed  
Causes

- Open phase
- Voltage imbalance between phases
- Defect of main circuit capacitor
- Defect of inverter PC board
- Defect of K1M
- Improper main circuit wiring

Troubleshooting



**Caution** Be sure to turn off power switch before connect or disconnect connector, or parts damage may be occurred.

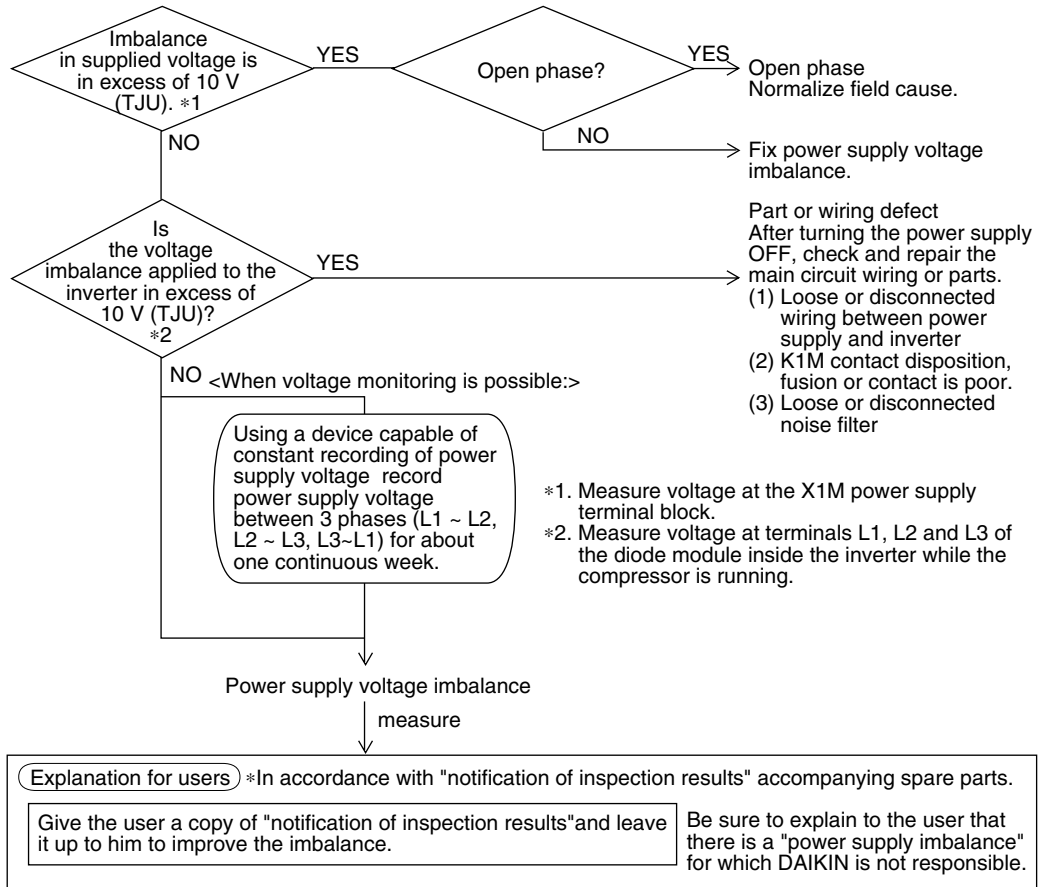

(V2816)

## 2.39 “P4” Outdoor Unit: Malfunction of Inverter Radiating Fin Temperature Rise Sensor

|  |  |
|--|--|
| <b>Remote Controller Display</b>       | P4   |
| <b>Applicable Models</b>               | RXYQ72M, 96M   |
| <b>Method of Malfunction Detection</b> | Resistance of radiation fin thermistor is detected when the compressor is not operating.   |
| <b>Malfunction Decision Conditions</b> | <p>When the resistance value of thermistor becomes a value equivalent to open or short circuited status.</p> <ul style="list-style-type: none"> <li>■ Malfunction is not decided while the unit operation is continued. "P4" will be displayed by pressing the inspection button.</li> </ul> |
| <b>Supposed Causes</b>                 | <ul style="list-style-type: none"> <li>■ Defect of radiator fin temperature sensor</li> <li>■ Defect of inverter PC board</li> </ul>   |

### Troubleshooting



**Caution**

Be sure to turn off power switch before connect or disconnect connector, or parts damage may be occurred.

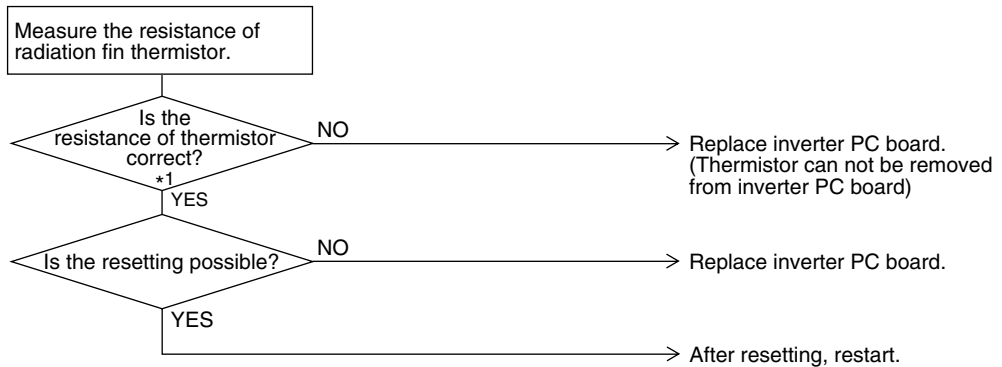

(V2818)



\*1: Refer to thermistor resistance / temperature characteristics table on P239.

## 2.40 “PJ” Outdoor Unit: Faulty Field Setting after Replacing Main PC Board or Faulty Combination of PC Board

|                                 |   |
|---------------------------------|---|
| Remote Controller Display       | PJ  |
| Applicable Models               | RXYQ72M, 96M  |
| Method of Malfunction Detection | The faulty (or no) field setting after replacing main PC board or faulty PC board combination is detected through communications with the inverter.       |
| Malfunction Decision Conditions | Whether or not the field setting or the type of the PC board is correct through the communication data is judged.   |
| Supposed Causes                 | <ul style="list-style-type: none"> <li>■ Faulty (or no) field setting after replacing main PC board</li> <li>■ Mismatching of type of PC board</li> </ul> |
| Troubleshooting                 |   |

**Caution**

Be sure to turn off power switch before connect or disconnect connector, or parts damage may be occurred.

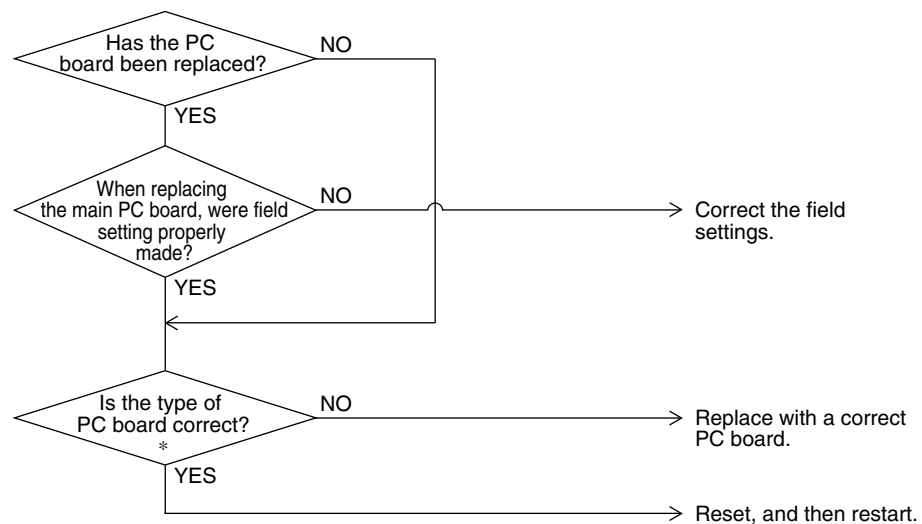

\*Note) Type of PC board mismatching includes;

- Main PC board
- Inverter PC board (for compressor)
- Fan driver PC board

## 2.41 “U0” Outdoor Unit: Low Pressure Drop Due to Refrigerant Shortage or Electronic Expansion Valve Failure

|   |   |
|---|---|
| <p><b>Remote Controller Display</b></p>       | <p>U0</p>   |
| <p><b>Applicable Models</b></p>               | <p>RXYQ72M, 96M</p>   |
| <p><b>Method of Malfunction Detection</b></p> | <p>Short of gas malfunction is detected by discharge pipe temperature thermistor.</p>   |
| <p><b>Malfunction Decision Conditions</b></p> | <p>Microcomputer judge and detect if the system is short of refrigerant.<br/>                 ★Malfunction is not decided while the unit operation is continued.</p>  |
| <p><b>Supposed Causes</b></p>                 | <ul style="list-style-type: none"> <li>■ Out of gas or refrigerant system clogging (incorrect piping)</li> <li>■ Defect of pressure sensor</li> <li>■ Defect of outdoor unit PC board (A1P)</li> <li>■ Defect of thermistor R2T or R4T</li> </ul> |

Troubleshooting



**Caution** Be sure to turn off power switch before connect or disconnect connector, or parts damage may be occurred.

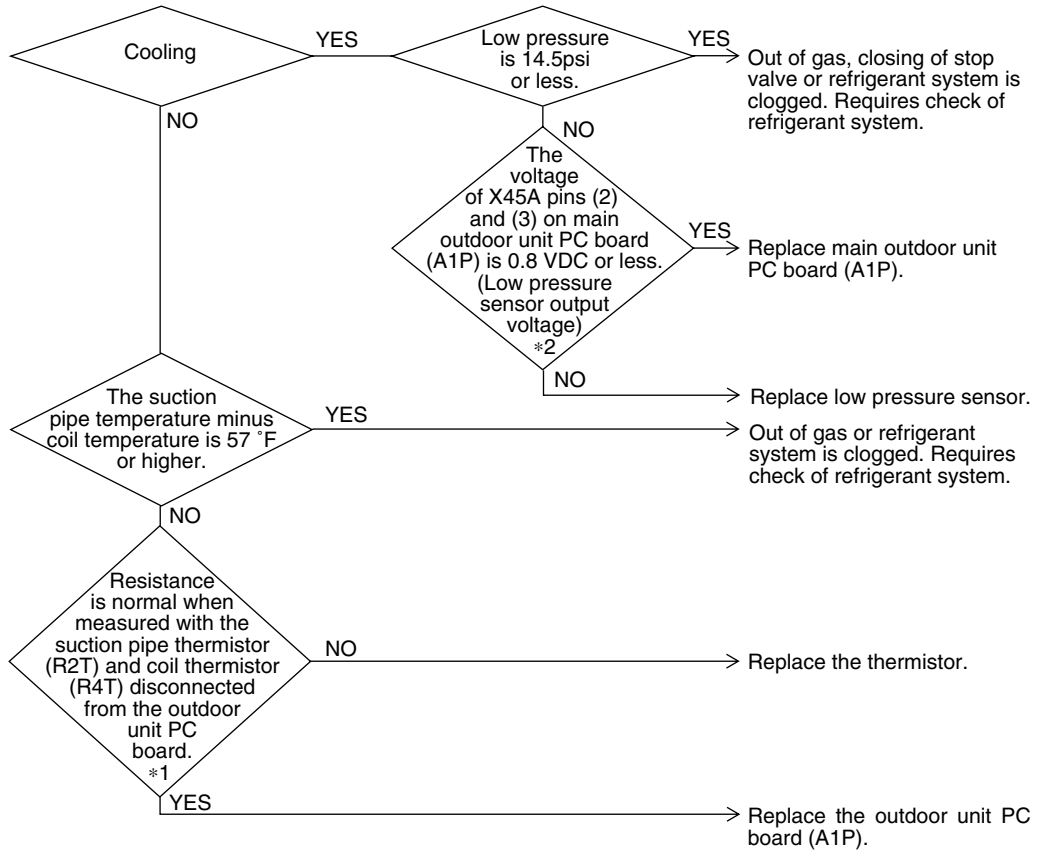

(V2819)



\*1: Refer to thermistor resistance / temperature characteristics table on P239.

\*2: Refer to pressure sensor, pressure / voltage characteristics table on P241.



## 2.42 “U1” Outdoor Unit: Reverse Phase, Open Phase

Remote  
Controller  
Display

U1

Applicable  
Models

RXYQ72M, 96M

Method of  
Malfunction  
Detection

Detection is based on the voltage in main circuit capacitor for inverter and supply voltage. The phase of each phase are detected by reverse phase detection circuit and right phase or reverse phase are judged.

Malfunction  
Decision  
Conditions

When a significant phase difference is made between phases.

Supposed  
Causes

- Power supply reverse phase
- Power supply open phase
- Defect of outdoor PC board (A1P)

### Troubleshooting



**Caution**

Be sure to turn off power switch before connect or disconnect connector, or parts damage may be occurred.

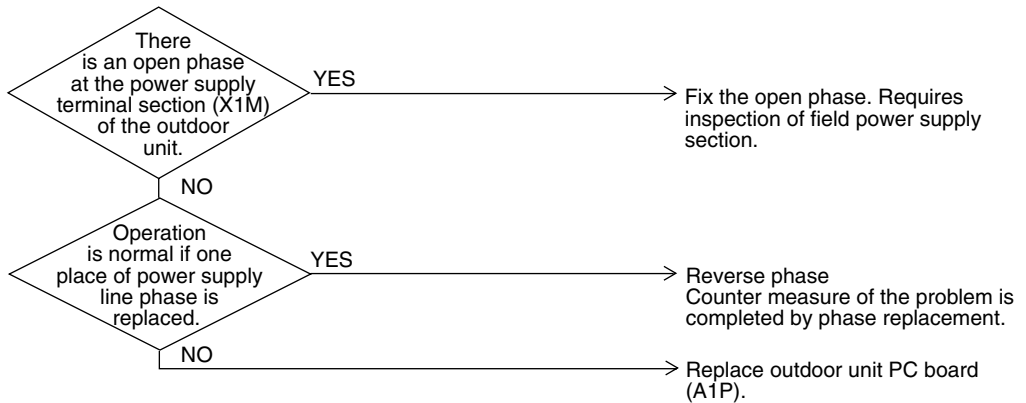

(V2820)

## 2.43 “U2” Outdoor Unit: Power Supply Insufficient or Instantaneous Failure

|  |   |
|--|---|
| <b>Remote Controller Display</b>       | U2  |
| <b>Applicable Models</b>               | RXYQ72M, 96M  |
| <b>Method of Malfunction Detection</b> | Detection of voltage of main circuit capacitor built in the inverter and power supply voltage.  |
| <b>Malfunction Decision Conditions</b> | When the capacitor above only has a voltage of 190 V or less.   |
| <b>Supposed Causes</b>                 | <ul style="list-style-type: none"> <li>■ Power supply insufficient</li> <li>■ Instantaneous failure</li> <li>■ Open phase</li> <li>■ Defect of inverter PC board</li> <li>■ Defect of outdoor control PC board</li> <li>■ Defect of K1M.</li> <li>■ Main circuit wiring defect</li> </ul> |

Troubleshooting



**Caution**

Be sure to turn off power switch before connect or disconnect connector, or parts damage may be occurred.

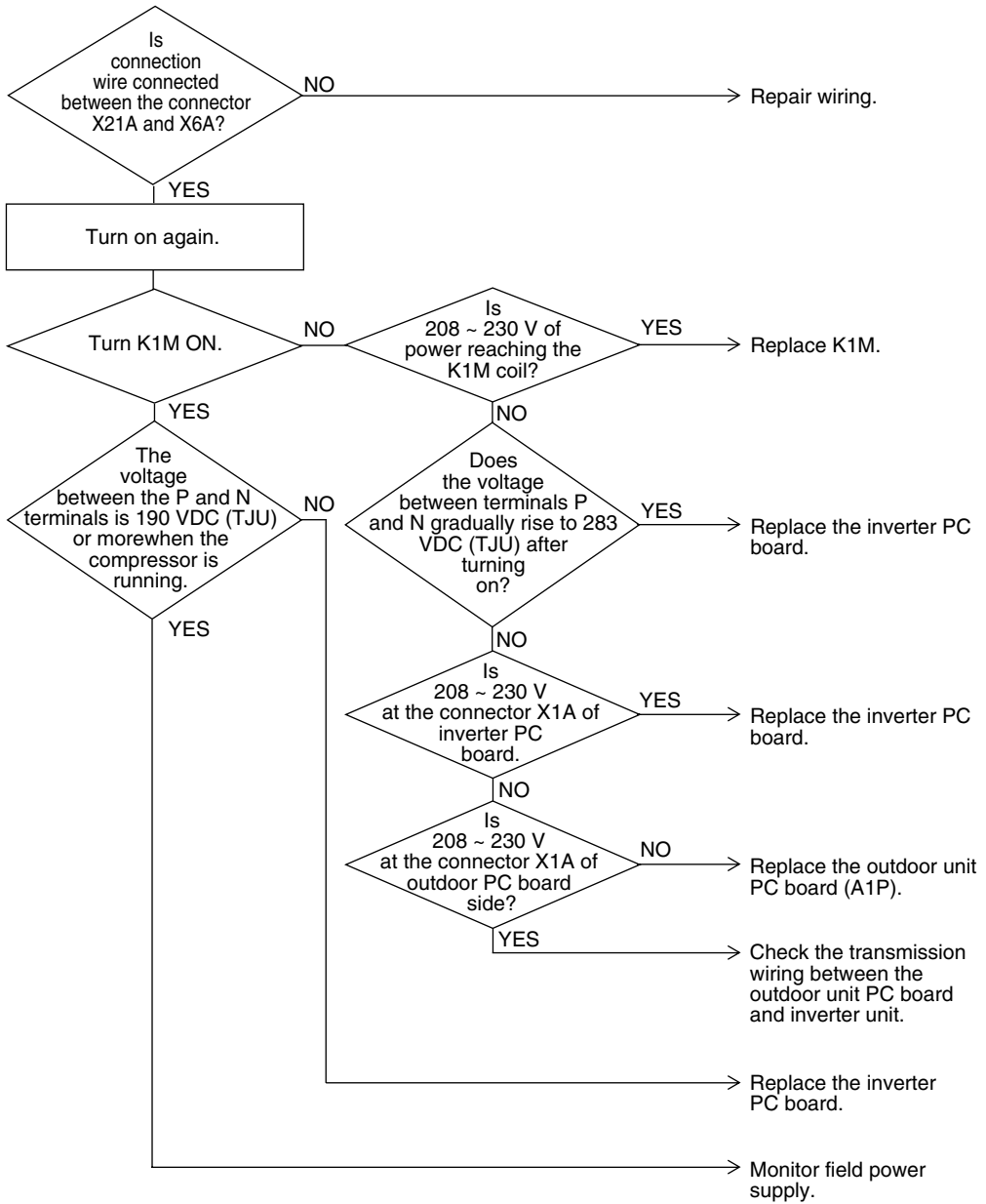

(V2821)

## 2.44 “U3” Outdoor Unit: Check Operation not executed

Remote  
Controller  
Display

U3

Applicable  
Models

RXYQ72M, 96M

Method of  
Malfunction  
Detection

Check operation is executed or not

Malfunction  
Decision  
Conditions

Malfunction is decided when the unit starts operation without check operation.

Supposed  
Causes

- Check operation is not executed.

Troubleshooting



**Caution**

Be sure to turn off power switch before connect or disconnect connector, or parts damage may be occurred.

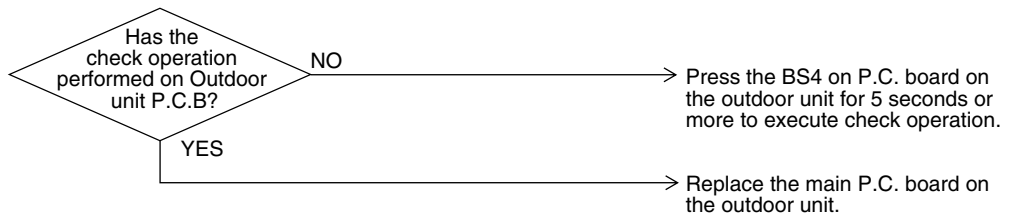

(V3052)

## 2.45 “U4” Malfunction of Transmission Between Indoor Units and Outdoor Units

|   |  |
|---|--|
| <p><b>Remote Controller Display</b></p>       | <p>U4</p>  |
| <p><b>Applicable Models</b></p>               | <p>All model of indoor unit<br/>RXYQ72M, 96M</p>   |
| <p><b>Method of Malfunction Detection</b></p> | <p>Microcomputer checks if transmission between indoor and outdoor units is normal.</p>  |
| <p><b>Malfunction Decision Conditions</b></p> | <p>When transmission is not carried out normally for a certain amount of time</p>  |
| <p><b>Supposed Causes</b></p>                 | <ul style="list-style-type: none"> <li>■ Indoor to outdoor, outdoor to outdoor transmission wiring F1, F2 disconnection, short circuit or wrong wiring</li> <li>■ Outdoor unit power supply is OFF</li> <li>■ System address doesn't match</li> <li>■ Defect of indoor unit PC board</li> <li>■ Defect of outdoor unit PC board</li> </ul> |

Troubleshooting



**Caution**

Be sure to turn off power switch before connect or disconnect connector, or parts damage may be occurred.

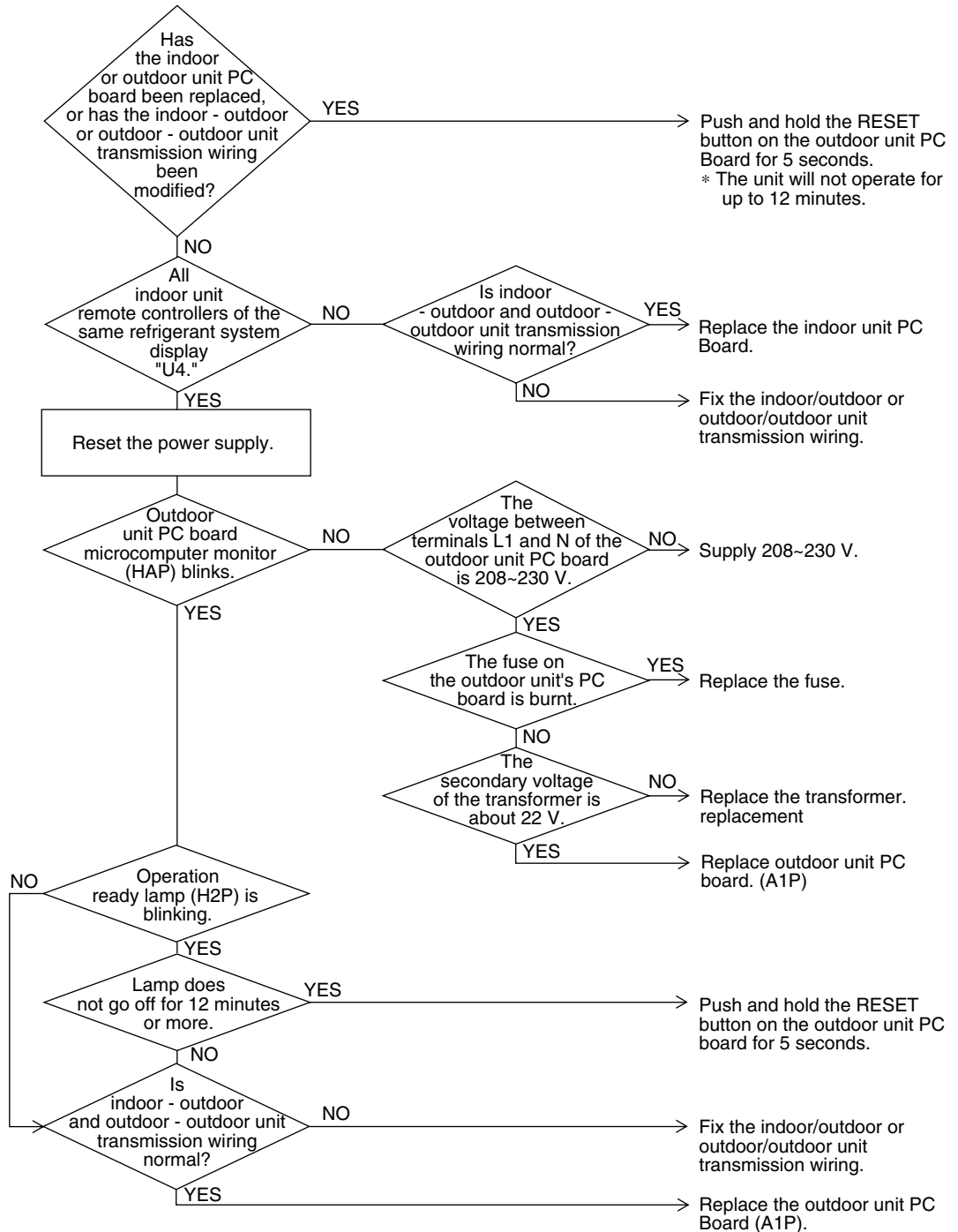

(V2822)

## 2.46 “U5” Indoor Unit: Malfunction of Transmission Between Remote Controller and Indoor Unit

|  |   |
|--|---|
| <b>Remote Controller Display</b>       | U5  |
| <b>Applicable Models</b>               | All models of indoor units  |
| <b>Method of Malfunction Detection</b> | In case of controlling with 2-remote controller, check the system using microcomputer is signal transmission between indoor unit and remote controller (main and sub) is normal.  |
| <b>Malfunction Decision Conditions</b> | Normal transmission does not continue for specified period.   |
| <b>Supposed Causes</b>                 | <ul style="list-style-type: none"> <li>■ Malfunction of indoor unit remote controller transmission</li> <li>■ Connection of two main remote controllers (when using 2 remote controllers)</li> <li>■ Defect of indoor unit PC board</li> <li>■ Defect of remote controller PC board</li> <li>■ Malfunction of transmission caused by noise</li> </ul> |

### Troubleshooting



**Caution** Be sure to turn off power switch before connect or disconnect connector, or parts damage may be occurred.

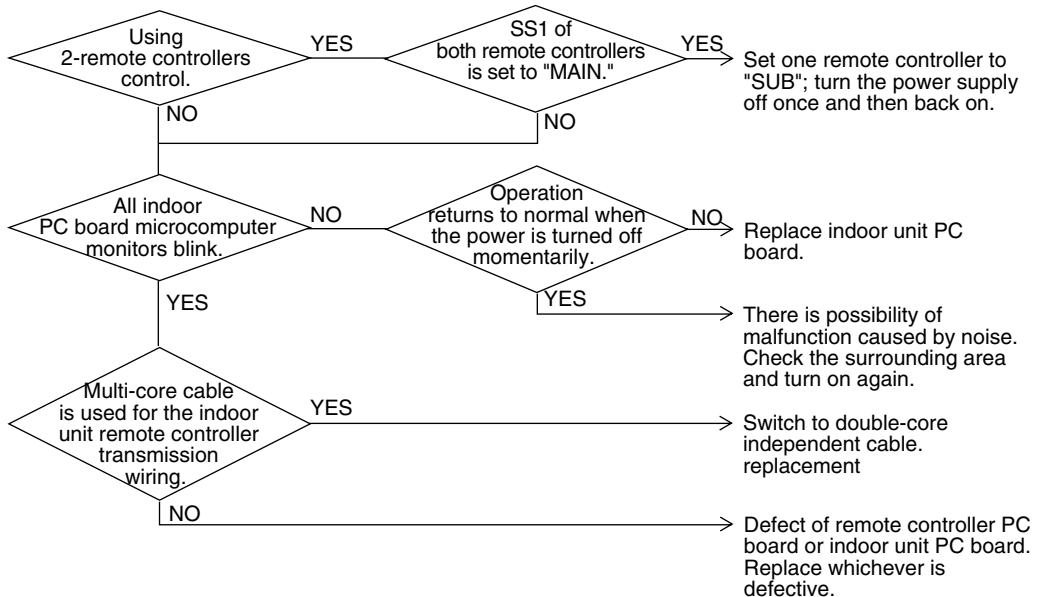

(V2823)

## 2.47 “U7” Indoor Unit: Malfunction of Transmission Between Outdoor Units

|  |   |
|--|---|
| <b>Remote Controller Display</b>       | U7  |
| <b>Applicable Models</b>               | All models of indoor units  |
| <b>Method of Malfunction Detection</b> | Microcomputer checks if transmission between outdoor units.   |
| <b>Malfunction Decision Conditions</b> | When transmission is not carried out normally for a certain amount of time  |
| <b>Supposed Causes</b>                 | <ul style="list-style-type: none"> <li>■ Improper connection of transmission wiring between outdoor unit and external control adaptor for outdoor unit.</li> <li>■ Improper cool/heat selection</li> <li>■ Improper cool/heat unified address (outdoor unit, external control adaptor for outdoor unit)</li> <li>■ Defect of outdoor unit PC board (A1P)</li> <li>■ Defect of external control adaptor for outdoor unit</li> <li>■ Improper connection of transmission wiring between outdoor units.</li> </ul> |



Troubleshooting

 **Caution** Be sure to turn off power switch before connect or disconnect connector, or parts damage may be occurred.

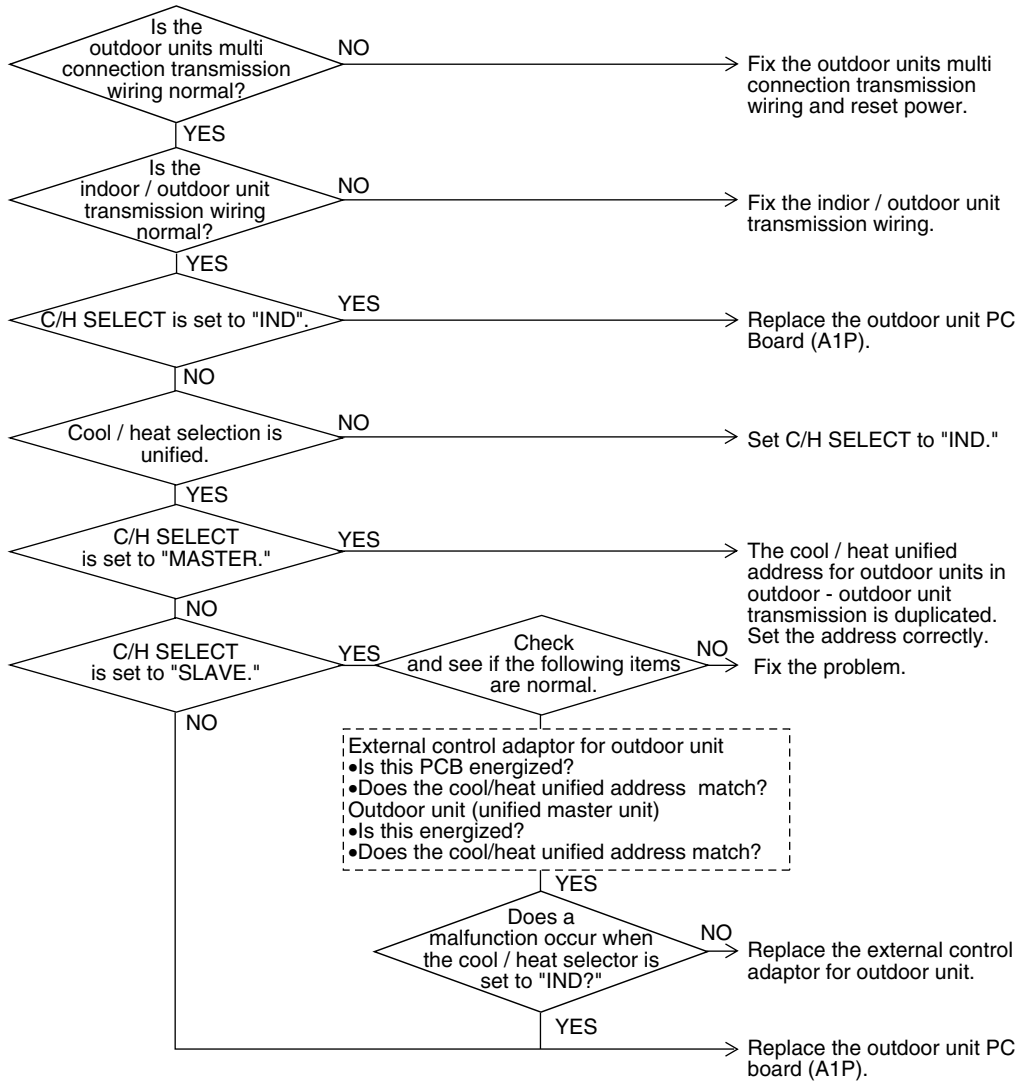

(V2824)

## 2.48 “U8” Indoor Unit: Malfunction of Transmission Between Main and Sub Remote Controllers

|  |   |
|--|---|
| <b>Remote Controller Display</b>       | <i>U8</i>   |
| <b>Applicable Models</b>               | All models of indoor units  |
| <b>Method of Malfunction Detection</b> | In case of controlling with 2-remote controller, check the system using microcomputer if signal transmission between indoor unit and remote controller (main and sub) is normal.  |
| <b>Malfunction Decision Conditions</b> | Normal transmission does not continue for specified period.   |
| <b>Supposed Causes</b>                 | <ul style="list-style-type: none"> <li>■ Malfunction of transmission between main and sub remote controller</li> <li>■ Connection between sub remote controllers</li> <li>■ Defect of remote controller PC board</li> </ul> |

### Troubleshooting



**Caution**

Be sure to turn off power switch before connect or disconnect connector, or parts damage may be occurred.

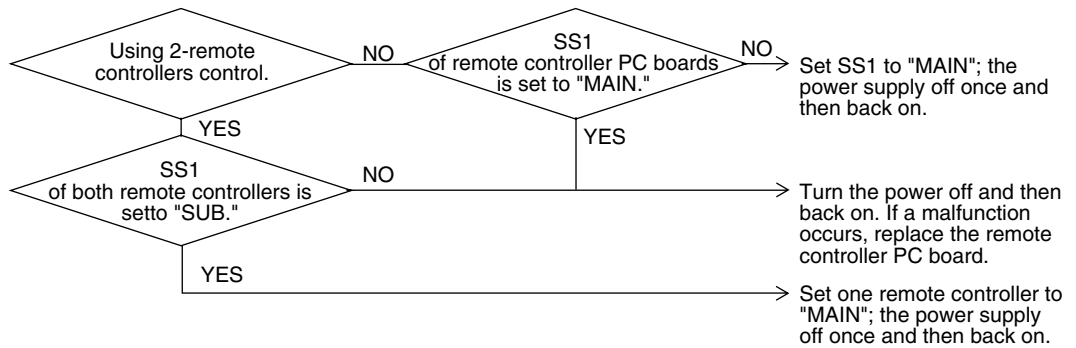

(V2825)

## 2.49 “U9” Indoor Unit: Malfunction of Transmission Between Indoor Units and Outdoor Units in the Same System

|  |  |
|--|--|
| <b>Remote Controller Display</b>       | <i>U9</i>  |
| <b>Applicable Models</b>               | All models of indoor units   |
| <b>Method of Malfunction Detection</b> | Detect the malfunction signal of any other indoor unit within the system concerned.  |
| <b>Malfunction Decision Conditions</b> | When the malfunction decision is made on any other indoor unit within the system concerned.  |
| <b>Supposed Causes</b>                 | <ul style="list-style-type: none"> <li>■ Malfunction of transmission within or outside of other system</li> <li>■ Malfunction of electronic expansion valve in indoor unit of other system</li> <li>■ Defect of PC board of indoor unit in other system</li> <li>■ Improper connection of transmission wiring between indoor and outdoor unit</li> </ul> |

Troubleshooting



**Caution**

Be sure to turn off power switch before connect or disconnect connector, or parts damage may be occurred.

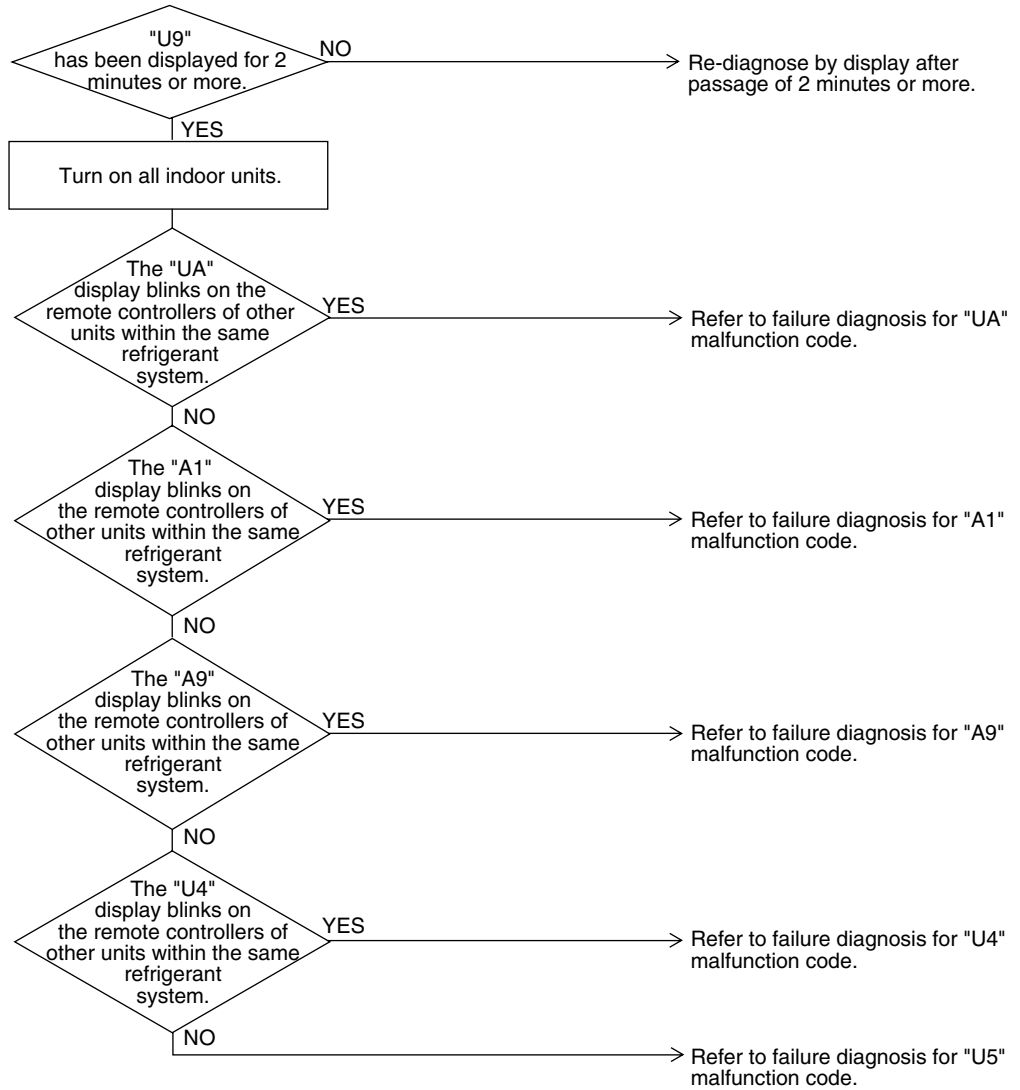

(V2826)

## 2.50 “UR” Improper Combination of Indoor Units and Outdoor Units/Indoor Units and Remote Controller

|   |  |
|---|--|
| <p><b>Remote Controller Display</b></p>       | <p>UR</p>  |
| <p><b>Applicable Models</b></p>               | <p>All indoor unit models<br/>RXYQ72M, 96M<br/>Remote controller</p>   |
| <p><b>Method of Malfunction Detection</b></p> | <p>A difference occurs in data by the type of refrigerant between indoor and outdoor units.<br/>The number of indoor units is outside of the allowable range.</p>  |
| <p><b>Malfunction Decision Conditions</b></p> | <p>The malfunction decision is made as soon as either of the abnormalities aforementioned is detected.</p>   |
| <p><b>Supposed Causes</b></p>                 | <ul style="list-style-type: none"> <li>■ Excess of connected indoor units</li> <li>■ Defect of outdoor unit PC board (A1P)</li> <li>■ Mismatching of the refrigerant type of indoor and outdoor unit</li> <li>■ Setting of outdoor PC board was not conducted after replacing to spare parts PC board</li> </ul> |

Troubleshooting



**Caution** Be sure to turn off power switch before connect or disconnect connector, or parts damage may be occurred.

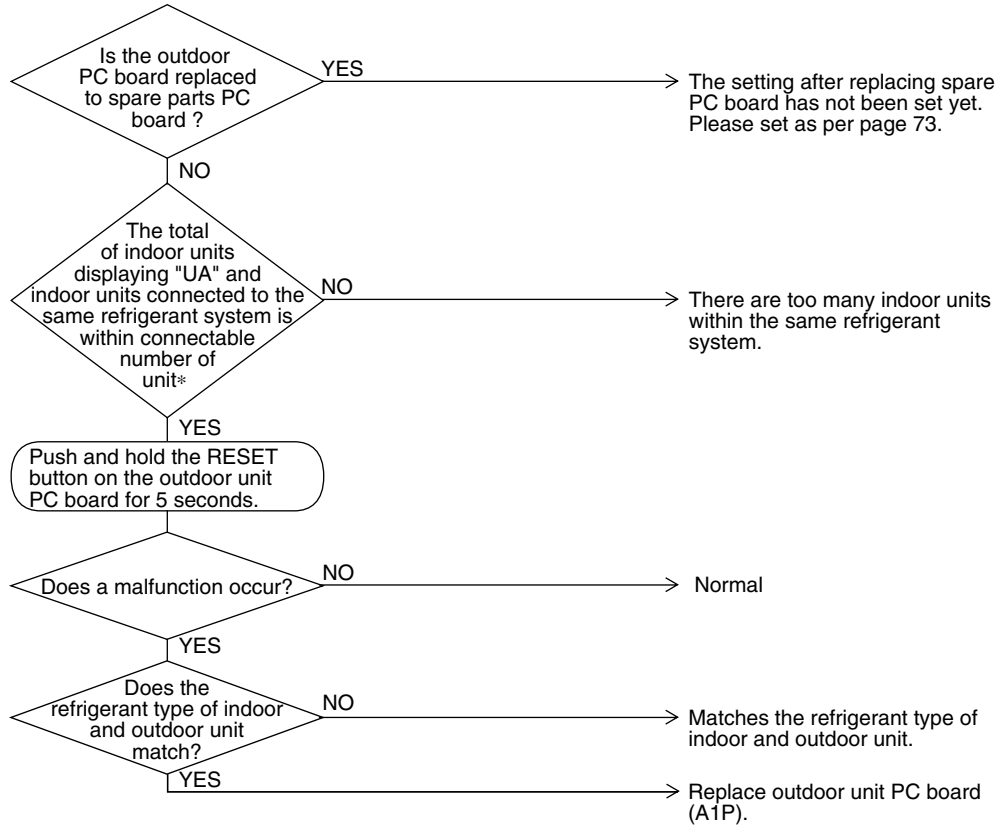

(V2827)

\* The number of indoor units that can be connected to a single outdoor unit system depends on the type of outdoor unit.

## 2.51 “UC” Address Duplication of Central Remote Controller

Remote Controller Display

UC

Applicable Models

All models of indoor unit  
Centralized controller

Method of Malfunction Detection

The principal indoor unit detects the same address as that of its own on any other indoor unit.

Malfunction Decision Conditions

The malfunction decision is made as soon as the abnormality aforementioned is detected.

Supposed Causes

- Address duplication of centralized remote controller
- Defect of indoor unit PC board

Troubleshooting



**Caution**

Be sure to turn off power switch before connect or disconnect connector, or parts damage may be occurred.

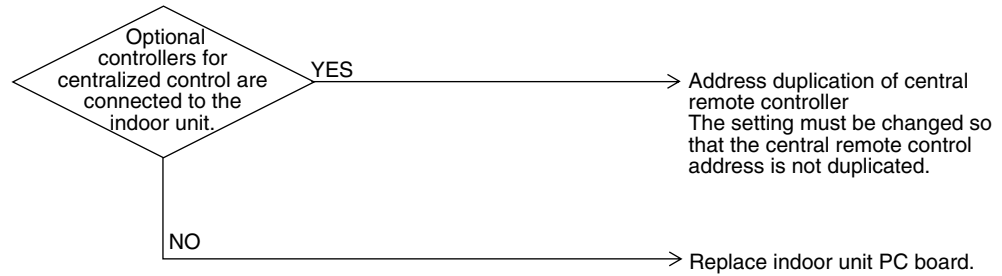

(V2828)

## 2.52 “UE” Malfunction of Transmission Between Centralized Controller and Indoor Unit

|  |  |
|--|--|
| <b>Remote Controller Display</b>       | UE   |
| <b>Applicable Models</b>               | All models of indoor units<br>Centralized controller   |
| <b>Method of Malfunction Detection</b> | Microcomputer checks if transmission between indoor unit and centralized controller is normal.   |
| <b>Malfunction Decision Conditions</b> | When transmission is not carried out normally for a certain amount of time   |
| <b>Supposed Causes</b>                 | <ul style="list-style-type: none"> <li>■ Malfunction of transmission between optional controllers for centralized control and indoor unit</li> <li>■ Connector for setting master controller is disconnected</li> <li>■ Failure of PC board for central remote controller</li> <li>■ Defect of indoor unit PC board</li> </ul> |



Troubleshooting



**Caution**

Be sure to turn off power switch before connect or disconnect connector, or parts damage may be occurred.

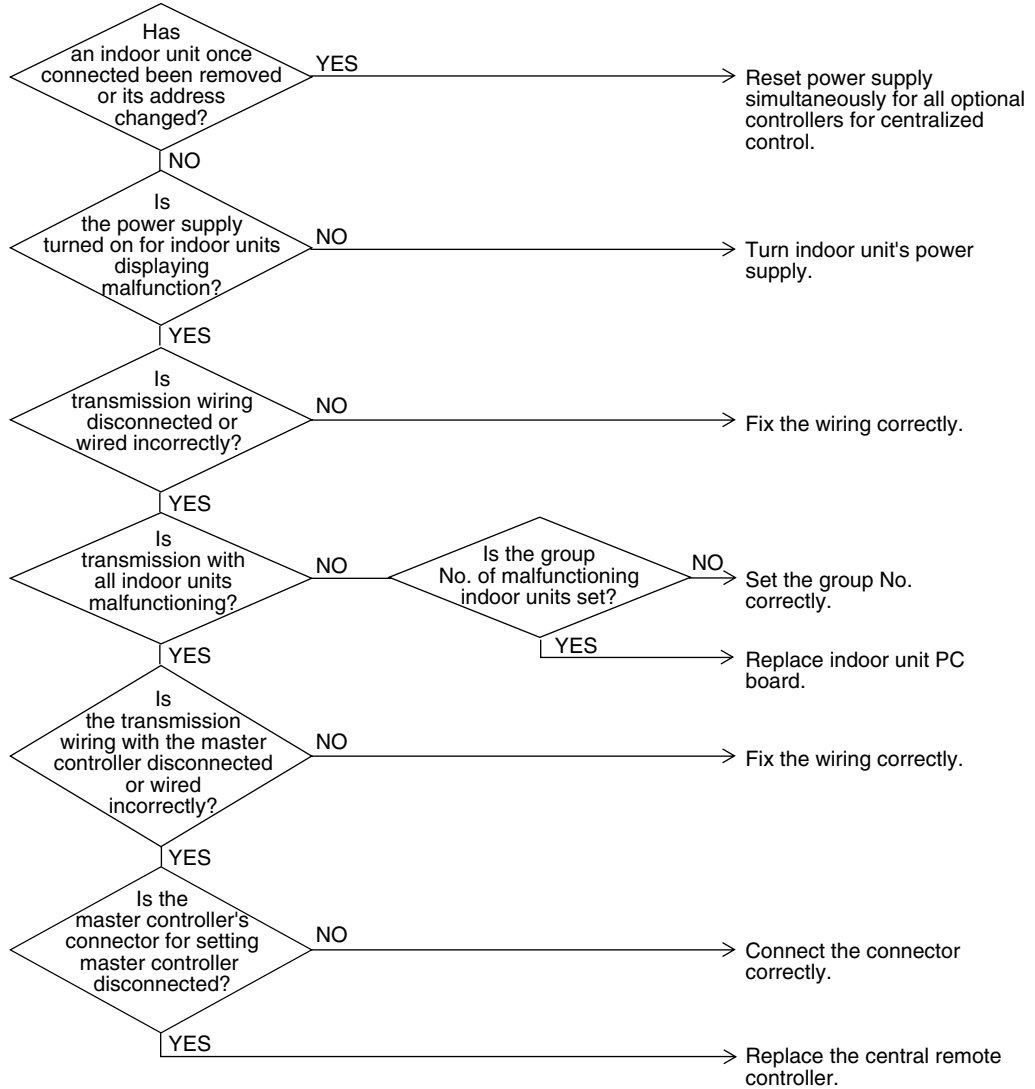

(V2829)

## 2.53 “UF” System is not Set yet

Remote  
Controller  
Display

UF

Applicable  
Models

All indoor units models  
RXYQ72M, 96M

Method of  
Malfunction  
Detection

The number of indoor units in terms of data transmission becomes mismatched to that of indoor units with changes in temperature on operation for checks.

Malfunction  
Decision  
Conditions

The malfunction is determined as soon as the abnormality aforementioned is detected through checking the system for any erroneous connection of units on the check operation.

Supposed  
Causes

- Improper connection of transmission wiring between indoor - outdoor unit and outdoor unit - external control adaptor for outdoor unit
- Failure to execute check operation
- Defect of indoor unit PC board
- Stop valve is left in closed

### Troubleshooting



**Caution**

Be sure to turn off power switch before connect or disconnect connector, or parts damage may be occurred.

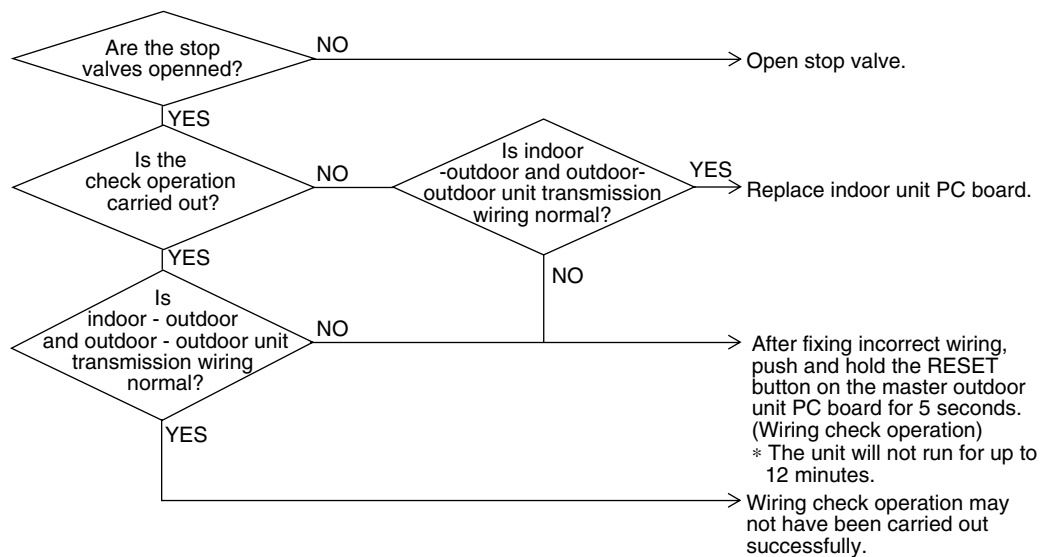

(V2830)



**Note:**

Wiring check operation may not be successful if carried out after the outdoor unit has been off for more than 12 hours, or if it is not carried out after running all connected indoor units in the fan mode for at least an hour.

## 2.54 “UH” Malfunction of System, Refrigerant System Address Undefined

|   |   |
|---|---|
| <p><b>Remote Controller Display</b></p>       | <p>UH</p>   |
| <p><b>Applicable Models</b></p>               | <p>All models of indoor units<br/>RXYQ72M, 96M</p>  |
| <p><b>Method of Malfunction Detection</b></p> |   |
| <p><b>Malfunction Decision Conditions</b></p> |   |
| <p><b>Supposed Causes</b></p>                 | <ul style="list-style-type: none"> <li>■ Improper connection of transmission wiring between indoor - outdoor unit and outdoor - outdoor unit.</li> <li>■ Defect of indoor unit PC board</li> <li>■ Defect of outdoor unit PC board (A1P)</li> </ul> |

Troubleshooting



**Caution** Be sure to turn off power switch before connect or disconnect connector, or parts damage may be occurred.

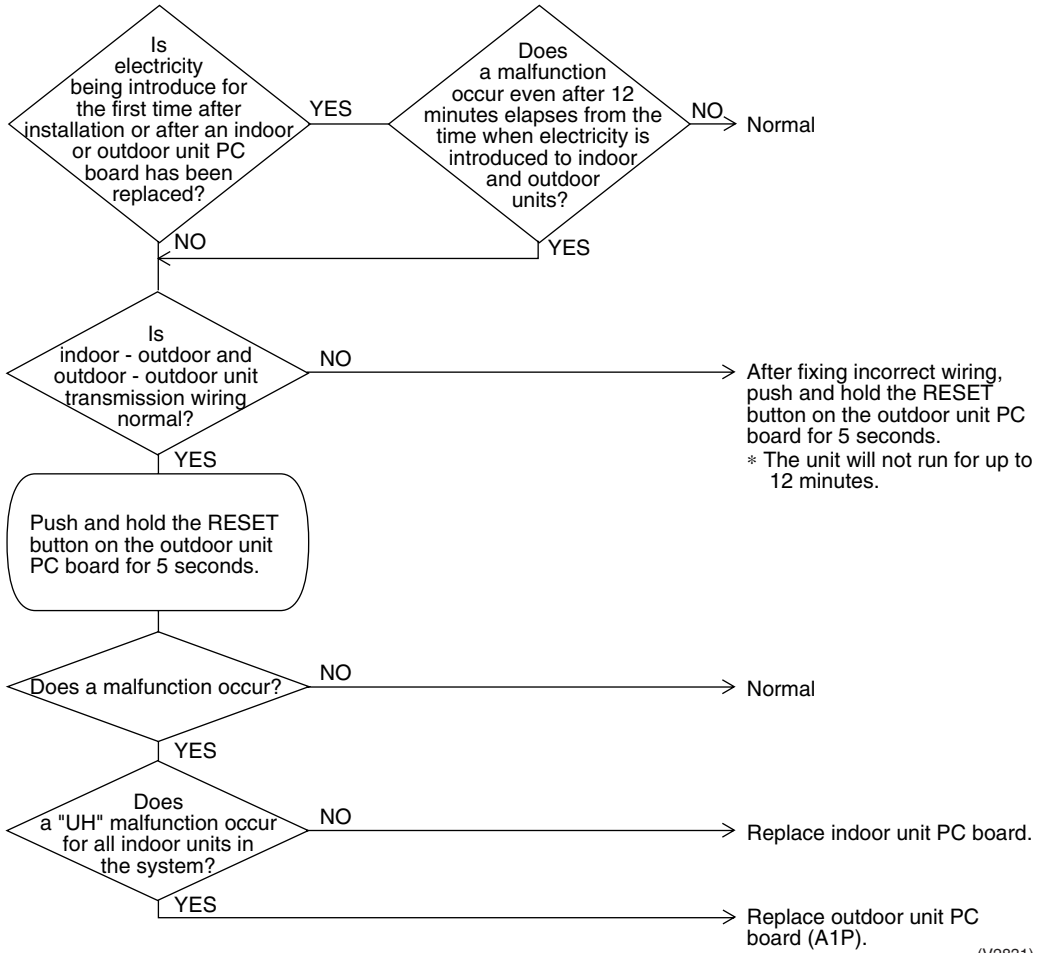

(V2831)

## 3. Troubleshooting (OP: Central Remote Controller)

### 3.1 “M1” PC Board Defect

|  |  |
|--|--|
| <b>Remote Controller Display</b>       | M1   |
| <b>Applicable Models</b>               | Central remote controller  |
| <b>Method of Malfunction Detection</b> | Detect an abnormality in the DIII-NET polarity circuit.  |
| <b>Malfunction Decision Conditions</b> | When + polarity and - polarity are detected at the same time.                                    |
| <b>Supposed Causes</b>                 | <ul style="list-style-type: none"> <li>■ Defect of central remote controller PC board</li> </ul> |
| <b>Troubleshooting</b>                 | Replace the central remote controller.   |

## 3.2 “MB” Malfunction of Transmission Between Optional Controllers for Centralized Control

|  |  |
|--|--|
| <b>Remote Controller Display</b>       | MB   |
| <b>Applicable Models</b>               | Central remote controller  |
| <b>Method of Malfunction Detection</b> | Detect the malfunction according to DIII-NET transmission data. (The system will be automatically reset.)  |
| <b>Malfunction Decision Conditions</b> | When no master controller is present at the time of the startup of slave controller.<br>When optional controllers for the centralized control which was connected once, shows no response.                         |
| <b>Supposed Causes</b>                 | <ul style="list-style-type: none"> <li>■ Malfunction of transmission between optional controllers for centralized control</li> <li>■ Defect of PC board of optional controllers for centralized control</li> </ul> |

Troubleshooting



**Caution** Be sure to turn off power switch before connect or disconnect connector, or parts damage may be occurred.

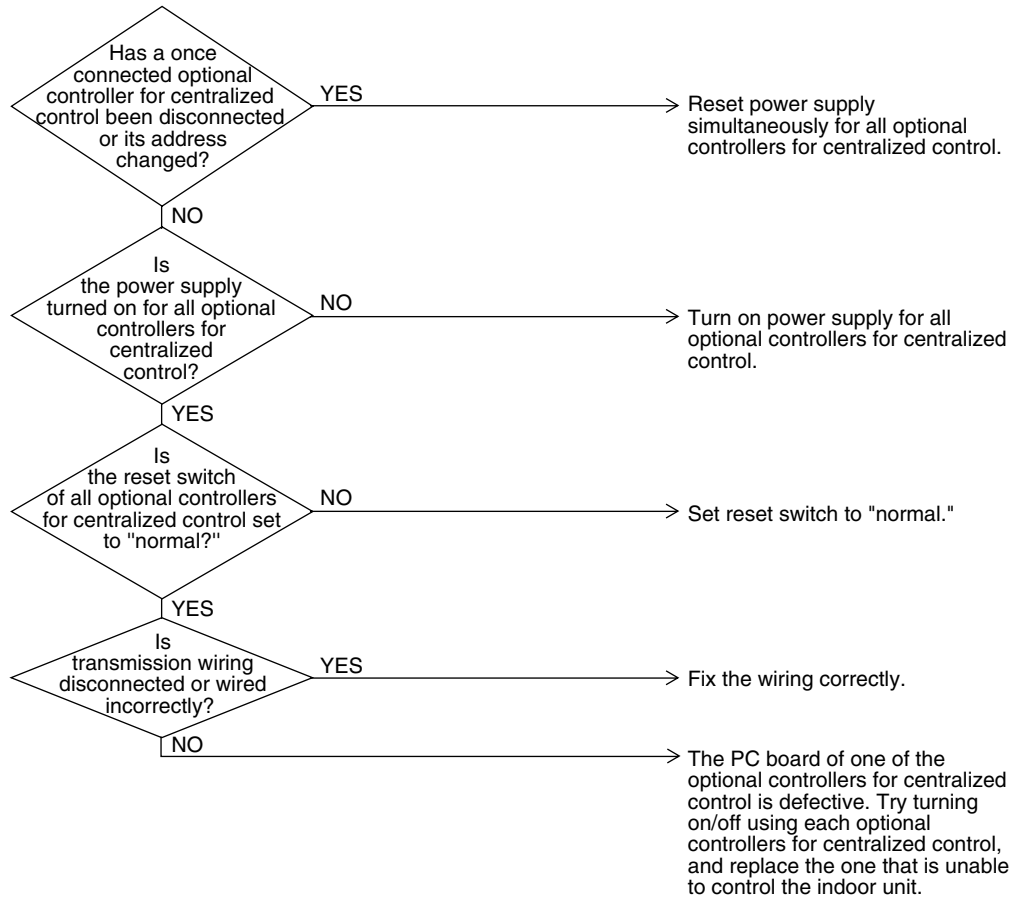

(V2833)

### 3.3 “*MR*” Improper Combination of Optional Controllers for Centralized Control

|                                 |   |
|---------------------------------|---|
| Remote Controller Display       | <i>MR</i>   |
| Applicable Models               | Central remote controller   |
| Method of Malfunction Detection | Detect the malfunction according to DIII-NET transmission data.   |
| Malfunction Decision Conditions | When the schedule timer is set to individual use mode, other central component is present.<br>When multiple master controller are present.<br>When the remote control adapter is present.   |
| Supposed Causes                 | <ul style="list-style-type: none"> <li>■ Improper combination of optional controllers for centralized control</li> <li>■ More than one master controller is connected</li> <li>■ Defect of PC board of optional controller for centralized control</li> </ul> |



Troubleshooting



**Caution** Be sure to turn off power switch before connect or disconnect connector, or parts damage may be occurred.

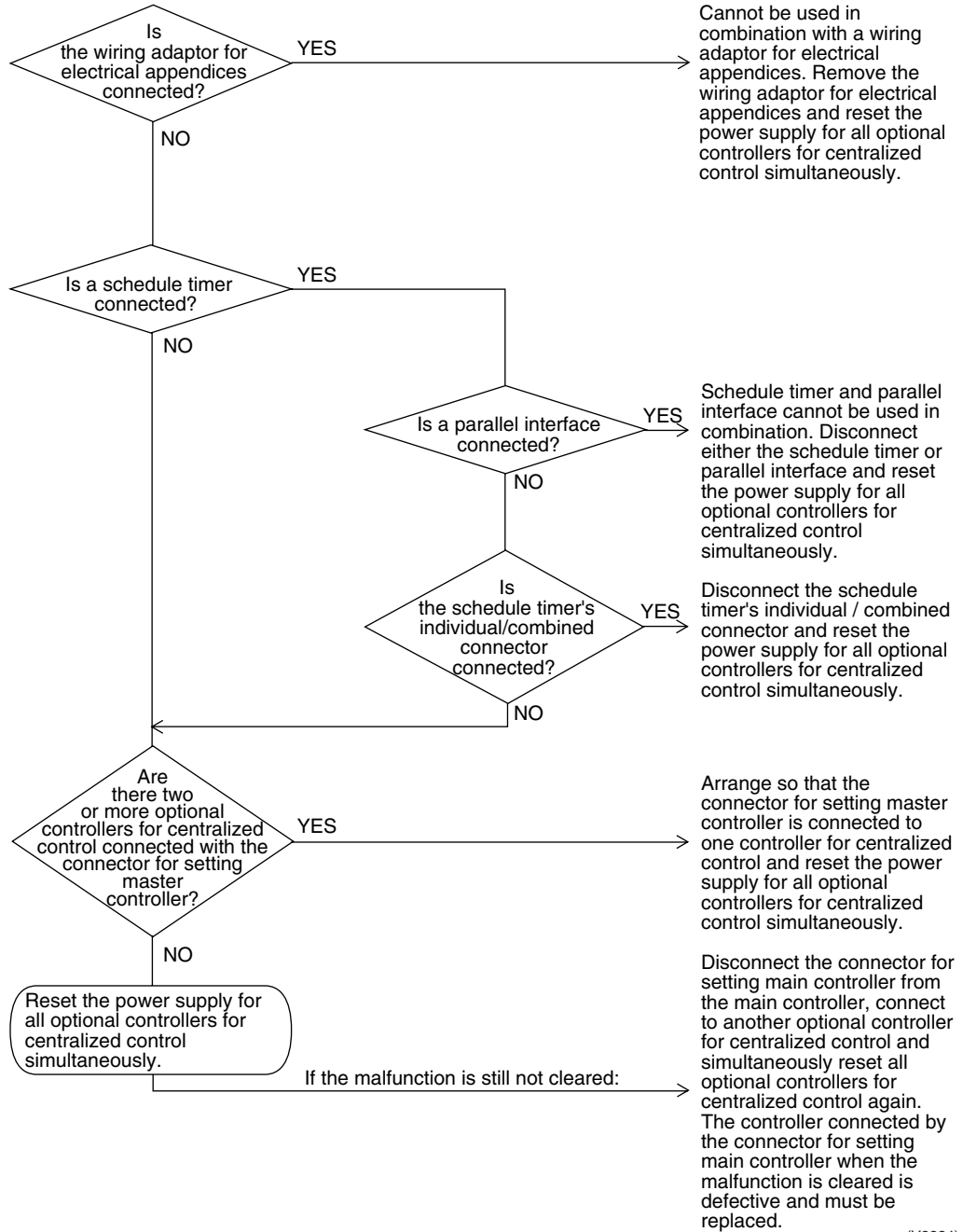

(V2834)

### 3.4 “MC” Address Duplication, Improper Setting

Remote  
Controller  
Display

MC

Applicable  
Models

Central remote controller

Method of  
Malfunction  
Detection

Detect the malfunction according to DIII-NET transmission data.

Malfunction  
Decision  
Conditions

Two units are both set to master controller mode or slave controller mode.

Supposed  
Causes

- Address duplication of centralized controller

Troubleshooting



**Caution**

Be sure to turn off power switch before connect or disconnect connector, or parts damage may be occurred.

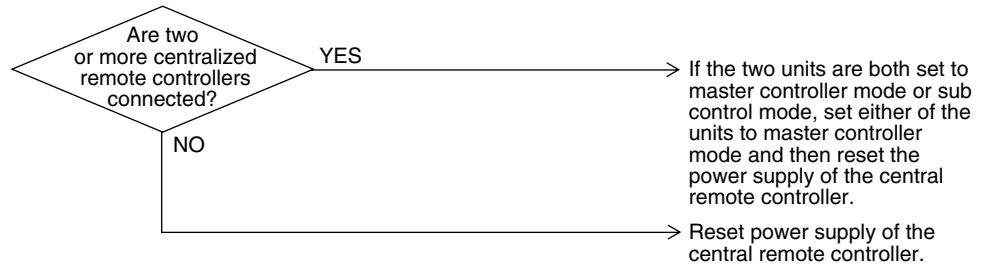

(V2835)

## 4. Troubleshooting (OP: Schedule Timer)

### 4.1 “UE” Malfunction of Transmission Between Central Remote Controller and Indoor Unit

|  |  |
|--|--|
| <b>Remote Controller Display</b>       | <i>UE</i>  |
| <b>Applicable Models</b>               | Schedule timer<br>Indoor units   |
| <b>Method of Malfunction Detection</b> | Microcomputer checks if transmission between indoor unit and centralized controller is normal.   |
| <b>Malfunction Decision Conditions</b> | When transmission is not carried out normally for a certain amount of time   |
| <b>Supposed Causes</b>                 | <ul style="list-style-type: none"> <li>■ Malfunction of transmission between centralized controller and indoor unit</li> <li>■ Disconnection of connector for setting master controller (or individual/combined switching connector)</li> <li>■ Defect of schedule timer PC board</li> <li>■ Defect of indoor unit PC board</li> </ul> |

Troubleshooting



**Caution** Be sure to turn off power switch before connect or disconnect connector, or parts damage may be occurred.

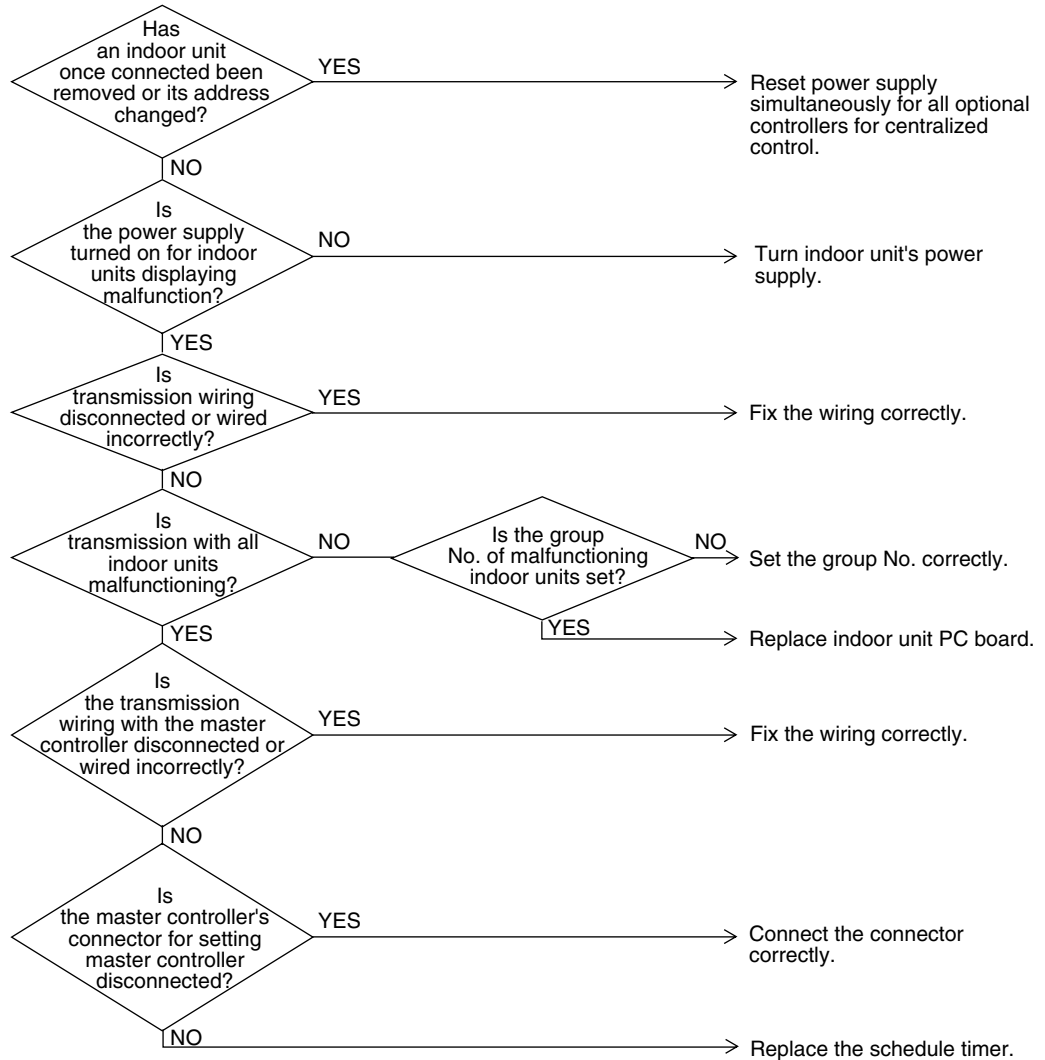

(V2836)

## 4.2 “M1” PC Board Defect

Remote  
Controller  
Display



Applicable  
Models

Schedule timer

Method of  
Malfunction  
Detection

Detect an abnormality in the DIII-NET polarity circuit.

Malfunction  
Decision  
Conditions

When + polarity and - polarity are detected at the same time.

Supposed  
Causes

- Defect of schedule timer PC board

Troubleshooting



**Caution**

Be sure to turn off power switch before connect or disconnect connector, or parts damage may be occurred.

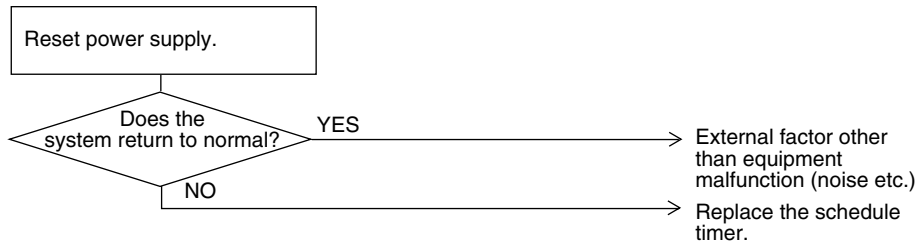

(V2837)

## 4.3 “M8” Malfunction of Transmission Between Optional Controllers for Centralized Control

|  |  |
|--|--|
| <b>Remote Controller Display</b>       | M8   |
| <b>Applicable Models</b>               | Schedule timer   |
| <b>Method of Malfunction Detection</b> | Detect the malfunction according to DIII-NET transmission data. (The system will be automatically reset.)  |
| <b>Malfunction Decision Conditions</b> | When no master controller at the time of the startup of slave controller.<br>When the optional controllers for centralized control which was connected once, shows no response.                                    |
| <b>Supposed Causes</b>                 | <ul style="list-style-type: none"> <li>■ Malfunction of transmission between optional controllers for centralized control</li> <li>■ Defect of PC board of optional controllers for centralized control</li> </ul> |

Troubleshooting



**Caution**

Be sure to turn off power switch before connect or disconnect connector, or parts damage may be occurred.

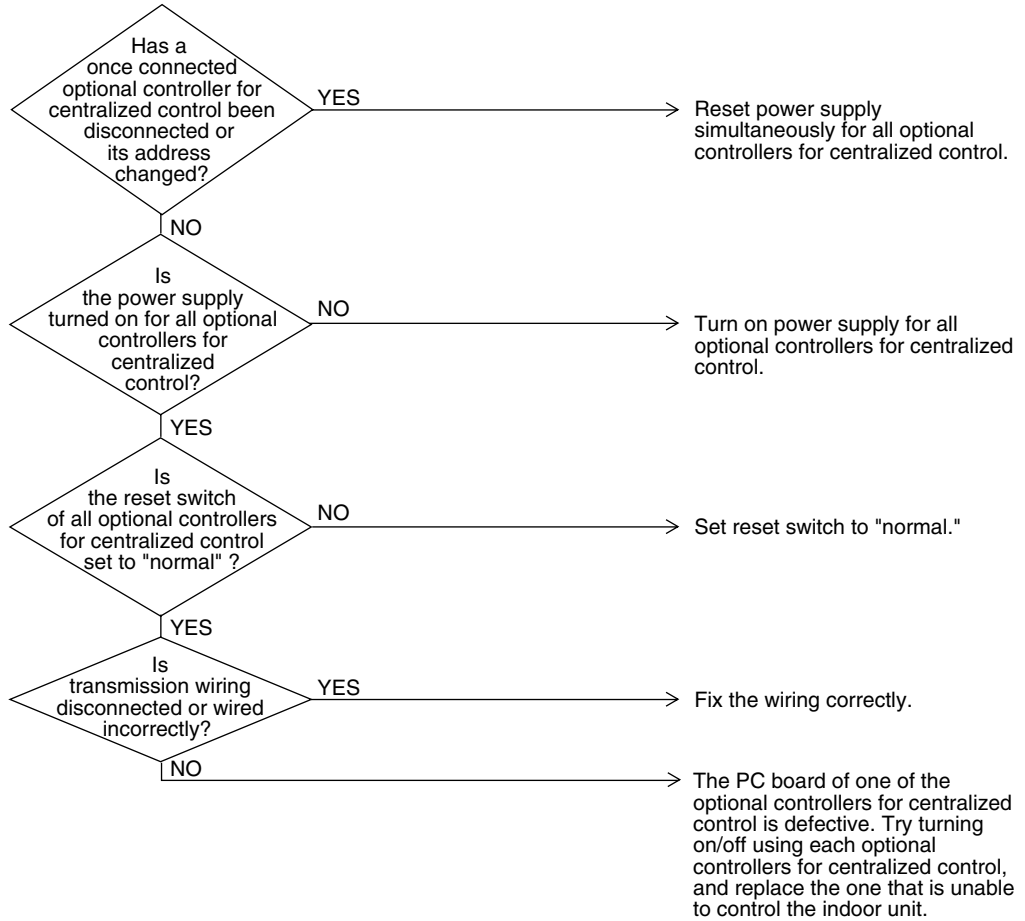

(V2838)

## 4.4 “*MR*” Improper Combination of Optional Controllers for Centralized Control

|  |  |
|--|--|
| <b>Remote Controller Display</b>       | <i>MR</i>  |
| <b>Applicable Models</b>               | Schedule timer   |
| <b>Method of Malfunction Detection</b> | Detect the malfunction according to DIII-NET transmission data.  |
| <b>Malfunction Decision Conditions</b> | When the schedule timer is set to individual use mode, other central component is present.<br>When multiple master controller are present.   |
| <b>Supposed Causes</b>                 | <ul style="list-style-type: none"> <li>■ Improper combination of optional controllers for centralized control</li> <li>■ More than one master controller is connected.</li> <li>■ Defect of PC board of optional controller for centralized control</li> </ul> |



Troubleshooting



**Caution** Be sure to turn off power switch before connect or disconnect connector, or parts damage may be occurred.

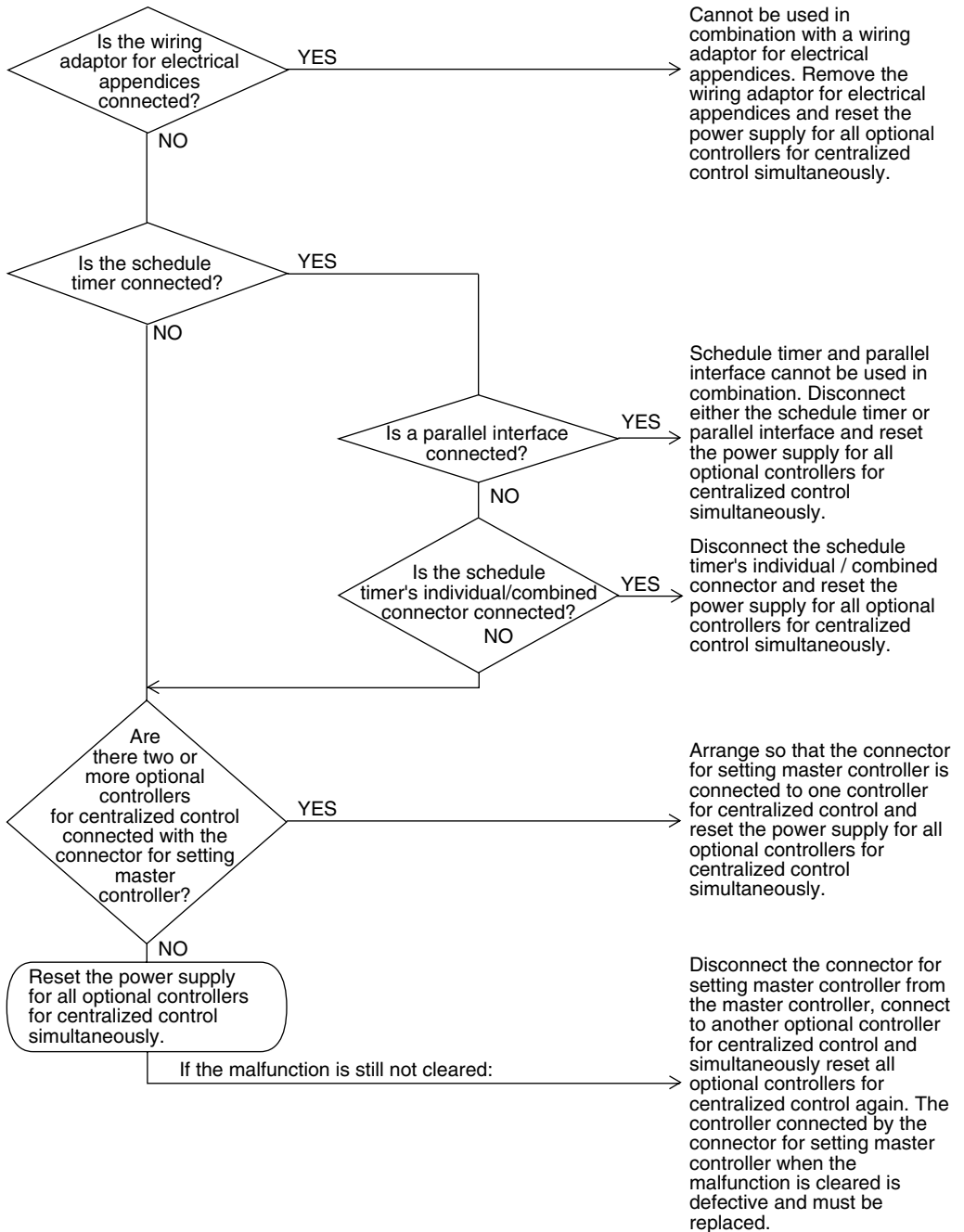

(V2839)

## 4.5 “MC” Address Duplication, Improper Setting

Remote  
Controller  
Display

MC

Applicable  
Models

schedule timer

Method of  
Malfunction  
Detection

Detect the malfunction according to DIII-NET transmission data.

Malfunction  
Decision  
Conditions

When two or more schedule timers are connected.

Supposed  
Causes

- Address duplication of schedule timer

Troubleshooting



**Caution**

Be sure to turn off power switch before connect or disconnect connector, or parts damage may be occurred.

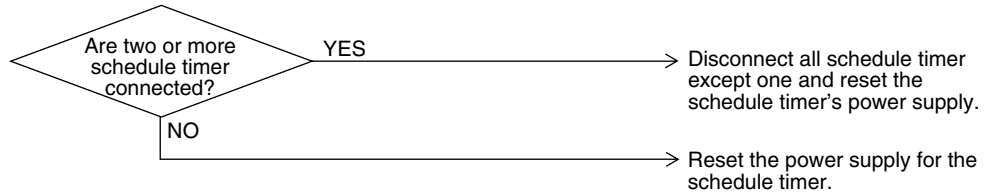

(V2840)

## 5. Troubleshooting (OP: Unified ON/OFF Controller)

### 5.1 Operation Lamp Blinks

**Remote  
Controller  
Display**

Operation lamp blinks

**Applicable  
Models**

All models of indoor units  
Unified ON/OFF controller

**Method of  
Malfunction  
Detection**

Detect the malfunction according to DIII-NET transmission data.

**Malfunction  
Decision  
Conditions**

**Supposed  
Causes**

- Malfunction of transmission between optional controller and indoor unit
- Connector for setting master controller is disconnected
- Defect of unified ON/OFF controller
- Defect of indoor unit PC board
- Malfunction of air conditioner

Troubleshooting



**Caution** Be sure to turn off power switch before connect or disconnect connector, or parts damage may be occurred.

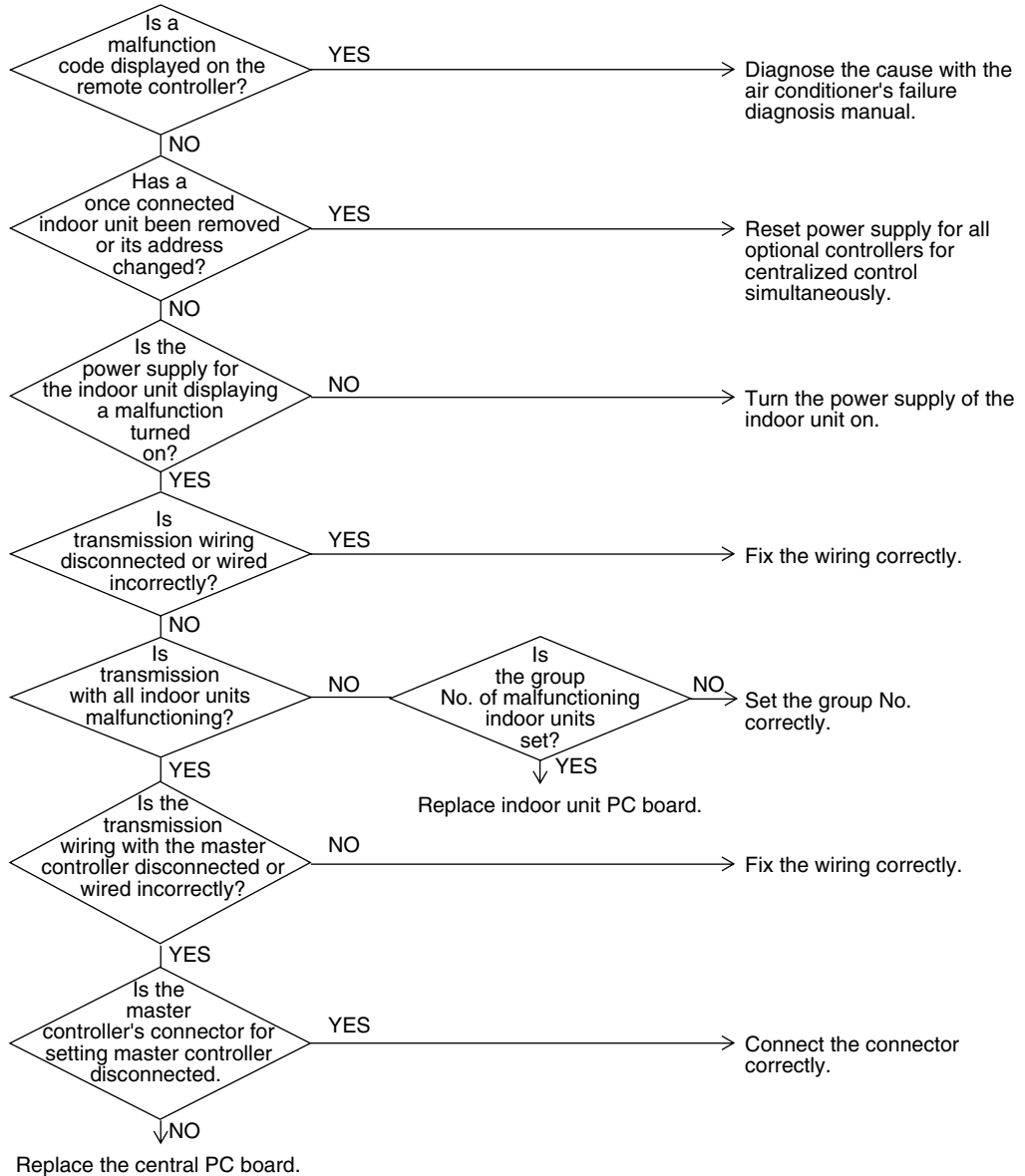

(V2841)

## 5.2 Display “Under Centralized Control” Blinks (Repeats Single Blink)

**Remote Controller Display**

 “under centralized control” (Repeats single blink)

**Applicable Models**

Unified ON/OFF controller  
 Central remote controller  
 Schedule timer

**Method of Malfunction Detection**

Detect the malfunction according to DIII-NET transmission data.

**Malfunction Decision Conditions**

When the centralized controller, which was connected once, shows no response.  
 The control ranges are overlapped.  
 When multiple master central controller are present.  
 When the schedule timer is set to individual use mode, other central controller is present.  
 When the wiring adaptor for electrical appendices is present.

**Supposed Causes**

- Address duplication of central remote controller
- Improper combination of optional controllers for centralized control
- Connection of more than one master controller
- Malfunction of transmission between optional controllers for centralized control
- Defect of PC board of optional controllers for centralized control

Troubleshooting



**Caution**

Be sure to turn off power switch before connect or disconnect connector, or parts damage may be occurred.

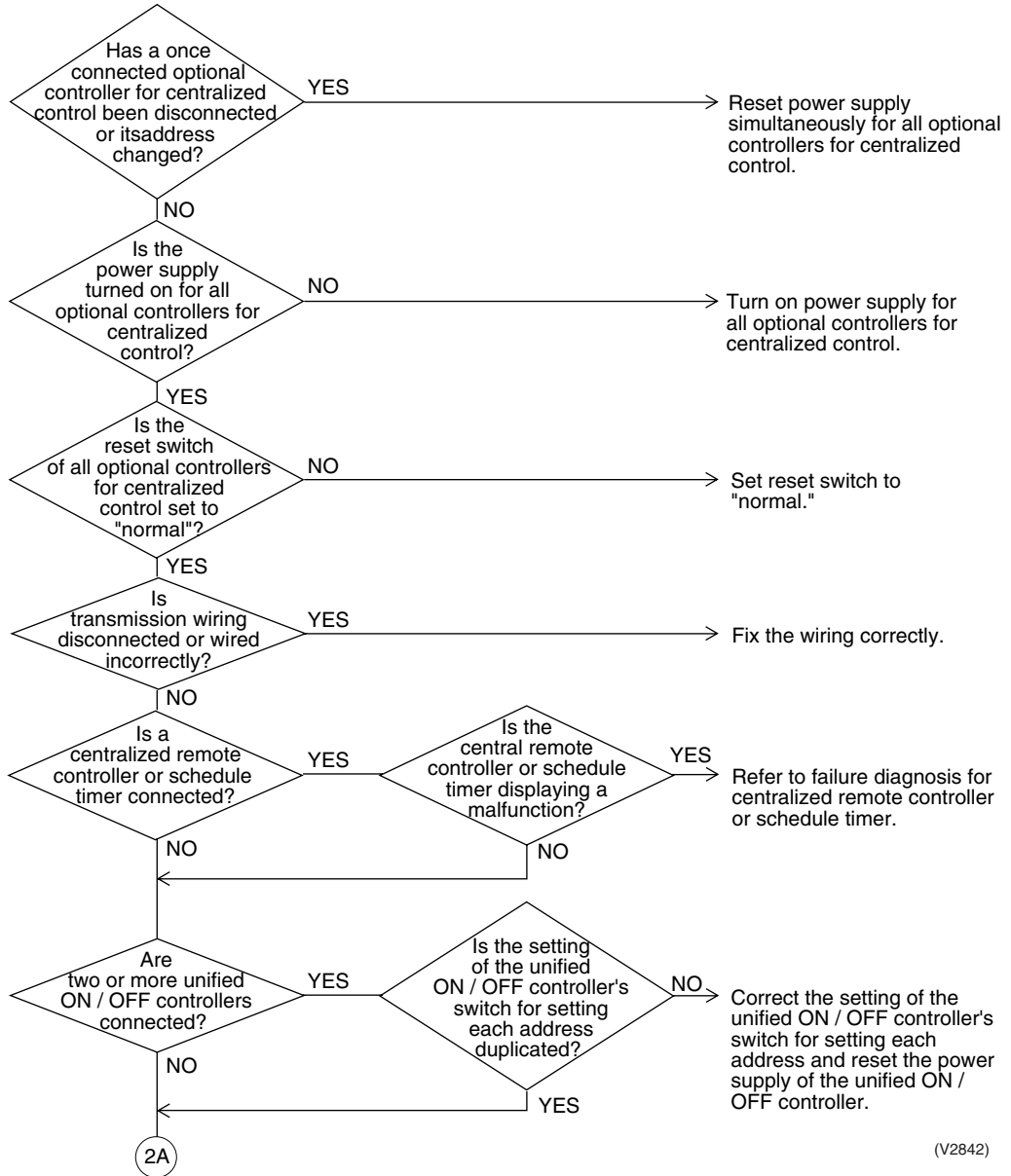

(V2842)

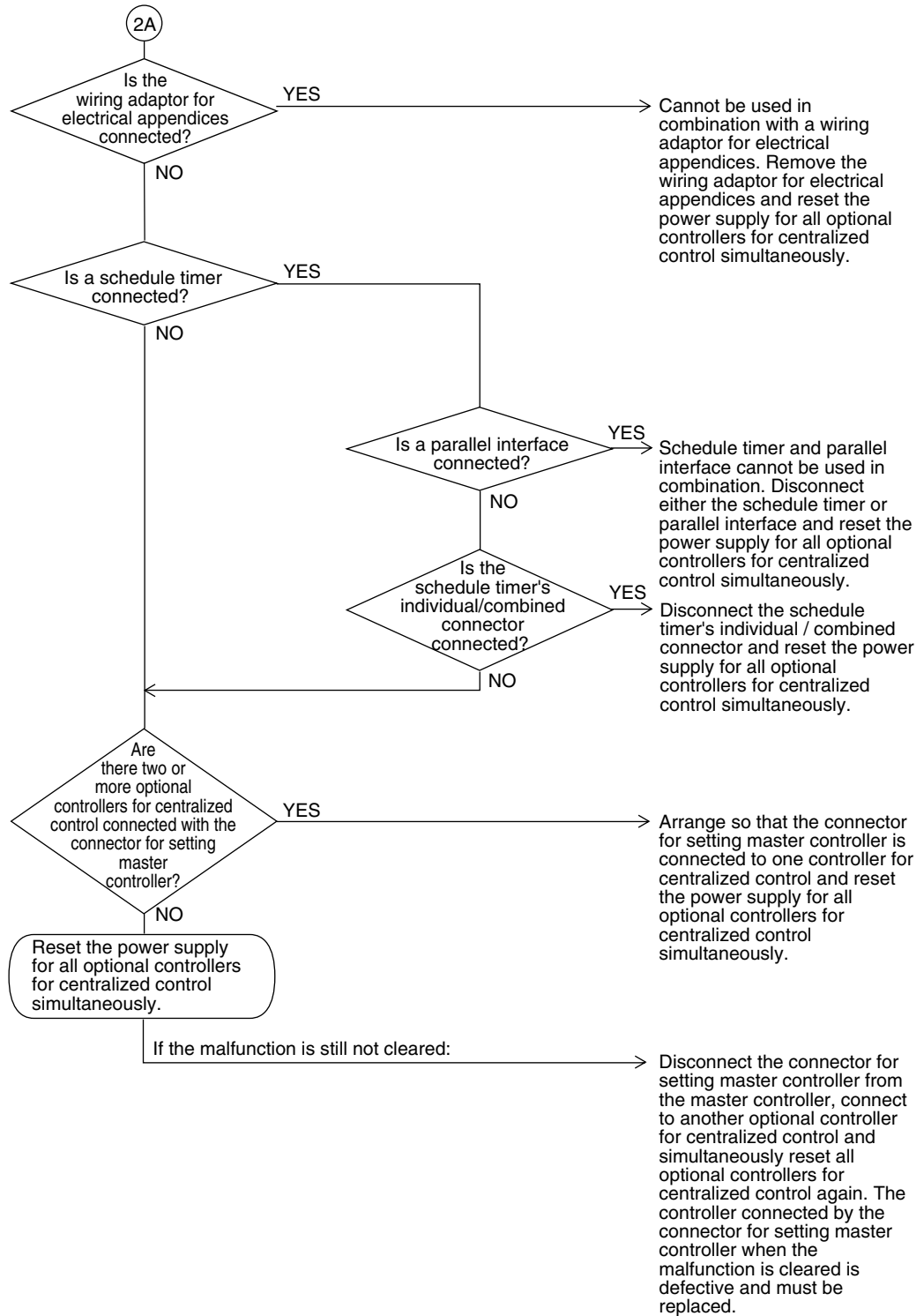

(V2843)

## 5.3 Display “Under Centralized Control” Blinks (Repeats Double Blink)

### Remote Controller Display

 “under centralized control” (Repeats double blink)

### Applicable Models

Unified ON/OFF controller

### Method of Malfunction Detection

Detect the malfunction according to DIII-NET transmission data.

### Malfunction Decision Conditions

When no central control addresses are set to indoor units.  
When no indoor units are connected within the control range.

### Supposed Causes

- Central control address (group No.) is not set for indoor unit.
- Improper control range setting switch
- Improper wiring of transmission wiring

### Troubleshooting



#### Caution

Be sure to turn off power switch before connect or disconnect connector, or parts damage may be occurred.

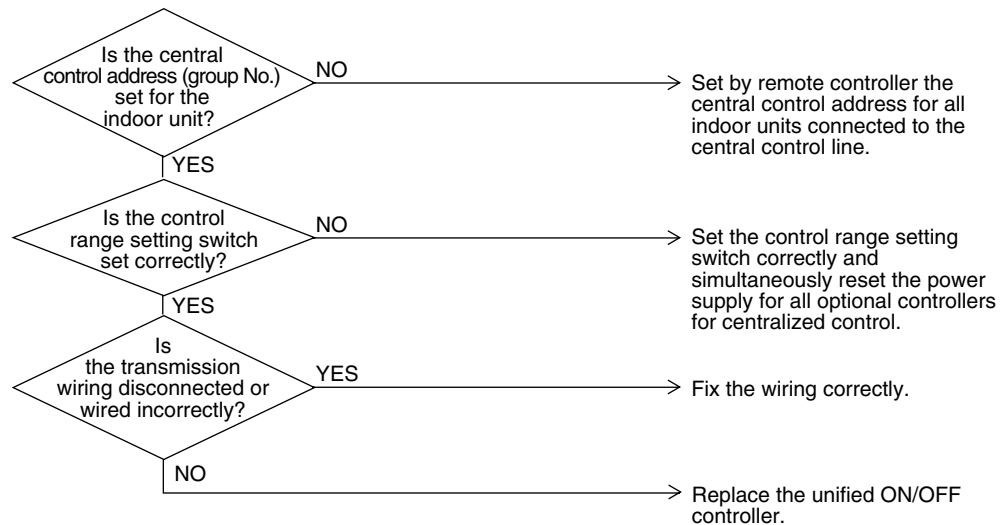

(V2844)



**Check No. 8**

**Check on connector of fan motor (Power supply cable)**

(1) Turn off the power supply.

Measure the resistance between phases of U,V,W at the motor side connectors (three-core wire) to check that the values are balanced and there is no short circuiting, while connector or relay connector is disconnected.

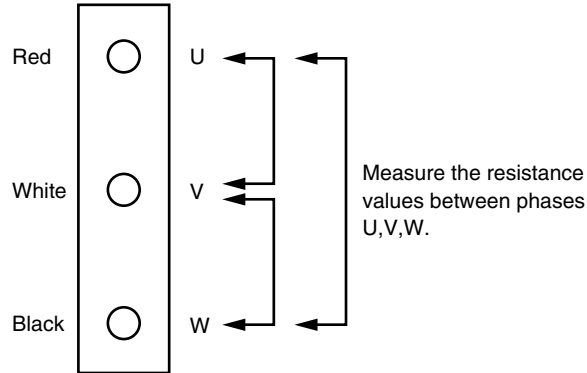

**Check No. 9**

**Check on connector of fan motor (Signal wire)**

(1) Turn off the power supply.

(2) Measure the resistance between Vcc and each phase of U,V,W, and GND and each phase at the motor side connectors (five-core wire) to check that the values are balanced within the range of  $\pm 20\%$ , while connector or relay connector is disconnected.

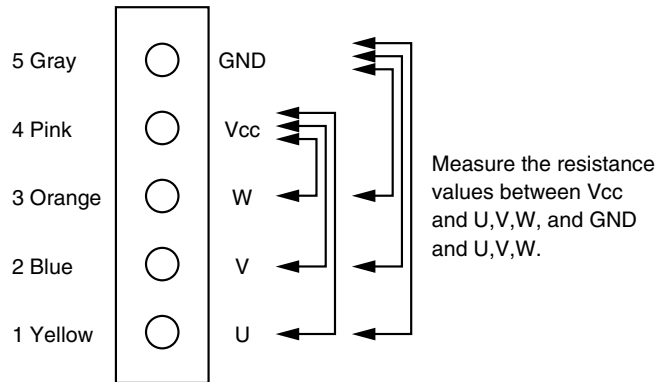

**Check No. 12****Check on pulse input of position signal of fan inverter PCB**

- (1) Disconnect the connector X2A while power supply OFF and operation OFF.
- (2) Is the voltage between pins No. 4 and 5 on X2A approx. 15 V after power supply is turned on?
- (3) Connect the connector X2A while power supply OFF and operation OFF.
- (4) Check below conditions when the fan motor is rotated one turn manually under the condition of operation OFF after power supply is turned ON.
  - Are the pulse (approx. 0 V and 5 V) generated 4 times between No. 1 and 5 on X2A?
  - Are the pulse (approx. 0 V and 5 V) generated 4 times between No. 2 and 5 on X2A?
  - Are the pulse (approx. 0 V and 5 V) generated 4 times between No. 3 and 5 on X2A?

The condition (2) dose not appear → Faulty PCB → Replacing the PCB  
 The conditions (4) do not appear → Faulty hall IC → Replacing fan motor of outdoor unit

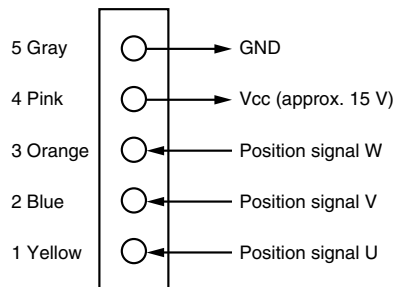
**Check No. 13****Power transistor check mode**

When the inverter system malfunctions (malfunction of inverter, INV compressor), to locate where the malfunction occurs, switching to the power transistor check mode of inverter in the service mode setting enables not to judge the position detection signal malfunction but to output waveform only during inverter operation. (The waveform can be checked by disconnecting the wiring of compressor.)

After the completion of checks, return the system to the previous mode and wait for 30 seconds or more until the discharge of capacitor is completed. Then, conduct a subsequent work.

**Notes:**

Be sure to disconnect the compressor wiring when conducting the check operation mentioned above.

When the output voltage is approx. 100~200 V (10 Hz) and the voltage balance between phases U-V,V-W, W-U is within  $\pm 5\%$ , the inverter PCB is normal.

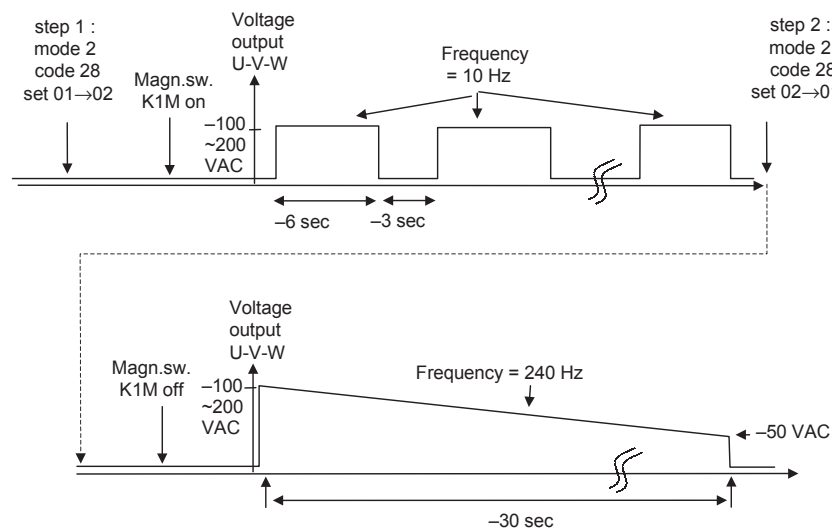

\* Voltage output will be different depend on measuring device.



# Part 7

# Replacement Procedure for INV Compressor, VRV

|  |     |
|--|-----|
| 1. Replacement Procedure for INV Compressor,<br>VRV (RXYQ72M, 96M) ..... | 218 |
| 1.1 Replacement Procedure.....   | 218 |

# 1. Replacement Procedure for INV Compressor, VRV (RXYQ72M, 96M)

## 1.1 Replacement Procedure

- (1) Collect the refrigerant by using refrigerant recovery unit.  
(Since the setting on outdoor unit PCB is required for refrigerant recovery, refer to the warning plate "Precautions in service work" attached on the switch box cover.)
- (2) Remove the sound insulator mat covering the faulty compressor, and disconnect the power cable from terminal board of the compressor.
- (3) Disconnect the brazing sections of suction pipe and discharge pipe by using brazing torch after the refrigerant has been collected completely.
- (4) Pinch the oil pressure equalizing pipe of the faulty compressor at the lower part of the brazed joint as shown in figure 1, and cut it between the pinched section and brazed joint in order to prevent residual oil from discharging.
- (5) Remove three bolts at cushion rubber section to take out the faulty compressor outside the unit.
- (6) Check that no oil remains in the oil pressure equalizing pipe as shown in figure 2, then remove the cut pipe from the brazed joint with brazing torch.
- (7) Install the new compressor in the unit.  
(Be sure to insert the cushion rubbers before tightening the fixing bolts of compressor.)
- (8) Remove the rubber caps put on the suction and discharge pipe of the new compressor to release the sealing nitrogen gas.  
(Take note that oil may spout due to the pipe inside pressure if the plug put on the equalizing seat is removed before removing of rubber cap.)
- (9) Remove the plug put on the equalizing seat of the new compressor.
- (10) Install the outlet pipe on the equalizing seat of the new compressor.
- (11) Braze the equalizing seat outlet pipe to the oil pressure equalizing pipe with brazing torch.  
\* Since an O-ring is put in the equalizing seat, be sure to maintain the parts around O-ring in cool.
- (12) Braze the suction and discharge pipe with brazing torch to the compressor.
- (13) Conduct air tight test to check the piping system is free from leakage.
- (14) Connect power cable to the terminal board of compressor and cover the compressor with sound insulator mat.
- (15) Conduct vacuum drying.  
(Since the setting on outdoor unit PCB is required for vacuum drying, refer to the warning plate "Precautions in service work" attached on the switch box cover.)
- (16) Charge refrigerant after the completion of vacuum drying, and check the function of compressor with cooling or heating operation.

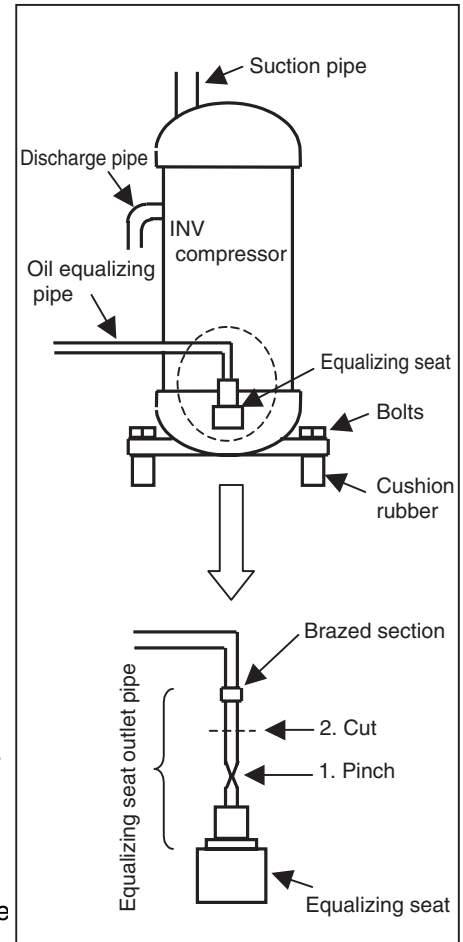

Fig. 1

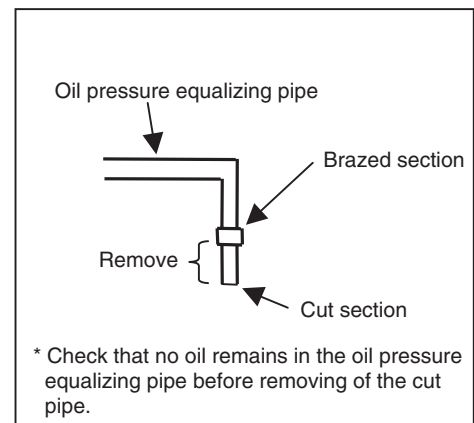

Fig. 2

# Part 8

## Appendix

|   |     |
|---|-----|
| 1. Piping Diagrams .....  | 220 |
| 1.1 Outdoor Unit .....  | 220 |
| 1.2 Indoor Unit .....   | 221 |
| 2. Wiring Diagrams for Reference .....  | 223 |
| 2.1 Outdoor Unit .....  | 223 |
| 2.2 Field Wiring .....  | 224 |
| 2.3 Indoor Unit .....   | 226 |
| 3. List of Electrical and Functional Parts .....                                    | 230 |
| 3.1 Outdoor Unit .....  | 230 |
| 3.2 Indoor Side .....   | 231 |
| 4. Option List .....  | 235 |
| 4.1 Option List of Controllers .....  | 235 |
| 4.2 Option Lists (Outdoor Unit) .....   | 236 |
| 5. Example of Connection .....  | 237 |
| 6. Thermistor Resistance / Temperature Characteristics .....                        | 239 |
| 7. Pressure Sensor .....  | 241 |
| 8. Method of Replacing The Inverter's Power Transistors and<br>Diode Modules .....  | 242 |
| 8.1 Method of Replacing The Inverter's Power Transistors and<br>Diode Modules ..... | 242 |

# 1. Piping Diagrams

## 1.1 Outdoor Unit

RXYQ72M, 96M

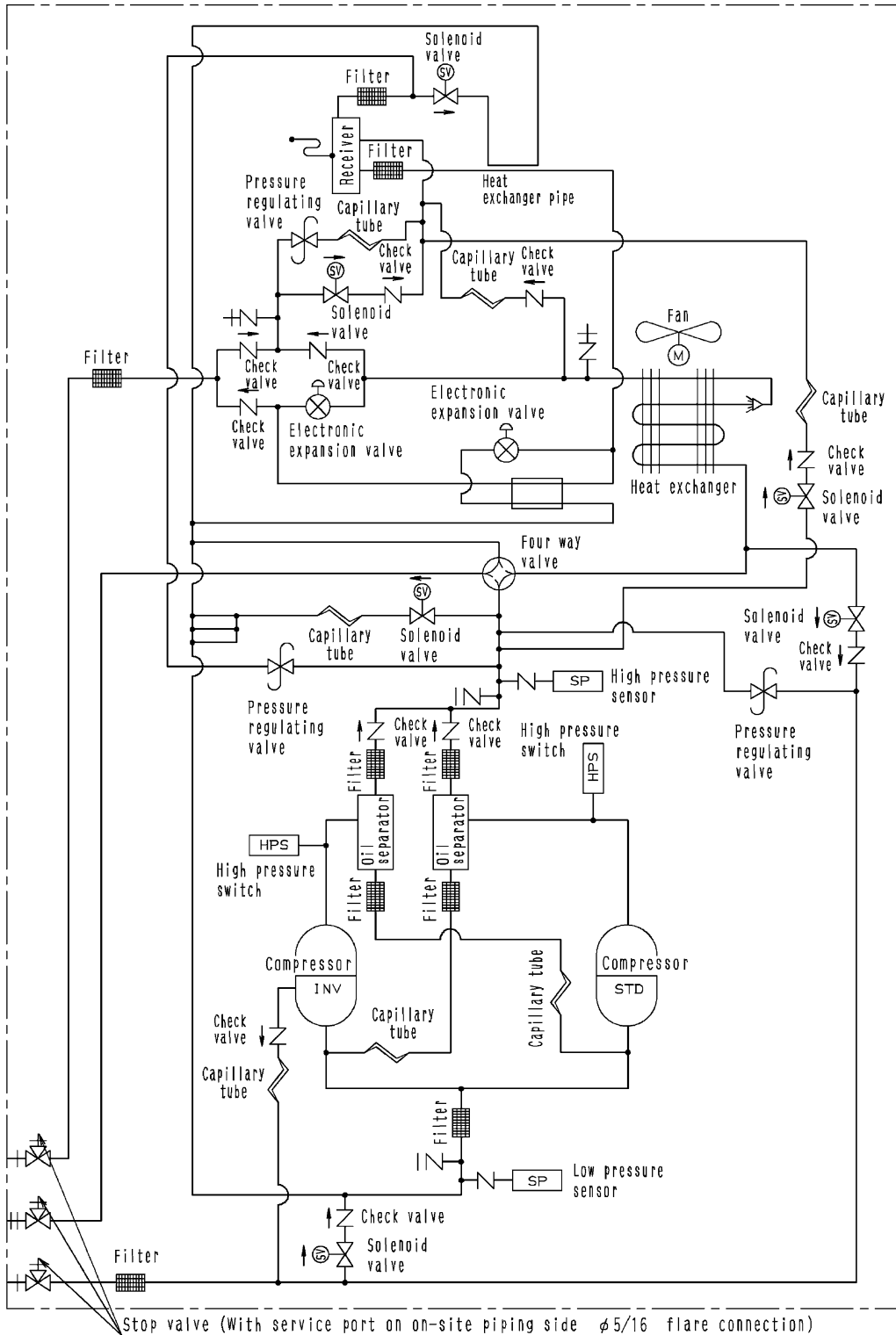

4D042651A

## 1.2 Indoor Unit

FXFQ 12M / 18M / 24M / 30M / 36MVJU

FXSQ 12M / 18M / 24M / 30M / 36M / 48MVJU

FXMQ 30M / 36M / 48MVJU

FXHQ 12M / 24M / 36MVJU

FXAQ 07M / 09M / 12M / 18M / 24MVJU

FXLQ 12M / 18M / 24MVJU

FXNQ 12M / 18M / 24MVJU

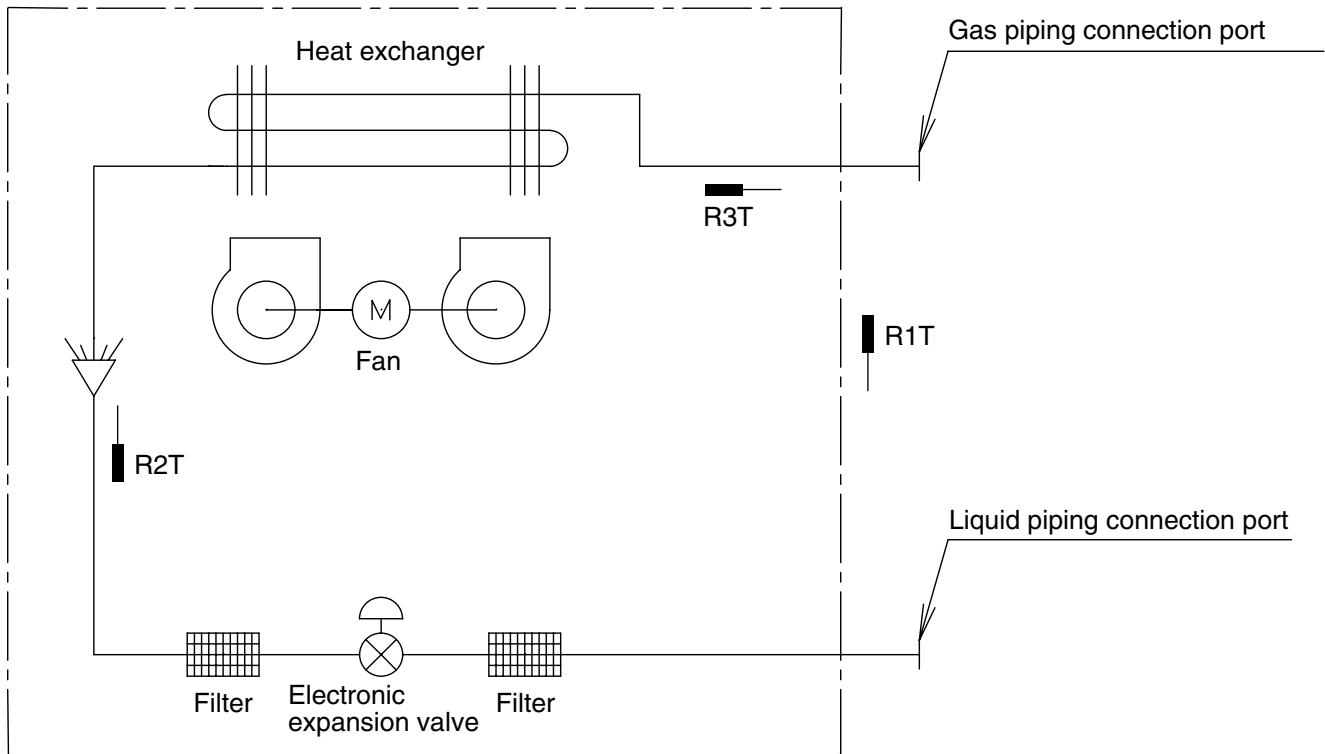

J:DU220-602J

R1T : Thermistor for suction air temperature

R2T : Thermistor for liquid line temperature

R3T : Thermistor for gas line temperature

| Capacity     | GAS        | Liquid     |
|--------------|------------|------------|
| 07/09/12/18M | $\phi 1/2$ | $\phi 1/4$ |
| 24/30/36/48M | $\phi 5/8$ | $\phi 3/8$ |



FXDQ

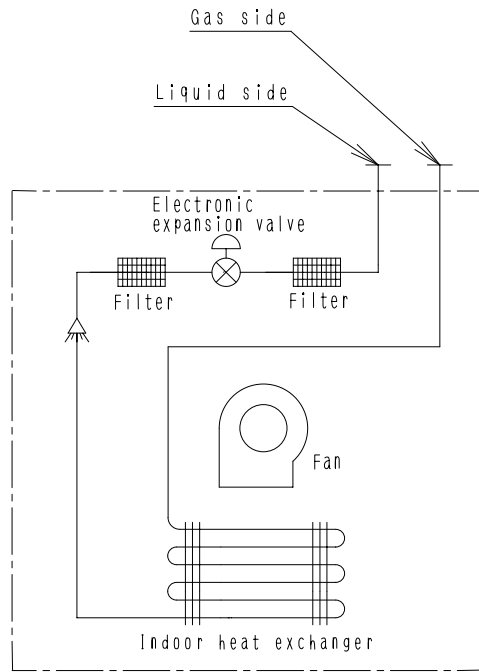

4D043864J

■ Refrigerant pipe connection port diameters

| Model                        | Gas  | Liquid |
|------------------------------|------|--------|
| FXDQ07M / 09M / 12M / 18MVJU | φ1/2 | φ1/4   |
| FXDQ24MVJU                   | φ5/8 | φ3/8   |



# 2.2 Field Wiring

## RXYQ72, 96MTJU

- Notes
- 1) All wiring, components and materials to be procured on the site must comply with the applicable local and national codes, use copper conductors only.
  - 2) Use copper conductors only.
  - 3) As for details, see wiring diagram.
  - 4) Install circuit breaker for safety.
  - 5) All field wiring and components must be provided by licensed electrician.
  - 6) Unit shall be grounded in compliance with the applicable local and national codes.
  - 7) Wiring shown is general points-of-connection guides only and is not intended for or to include all details for a specific installation.
  - 8) Be sure to install the switch and the fuse to the power line of each equipment.
  - 9) Install the main switch that can interrupt all the power sources in an integrated manner because this system consists of the equipment utilizing the multiple power sources.

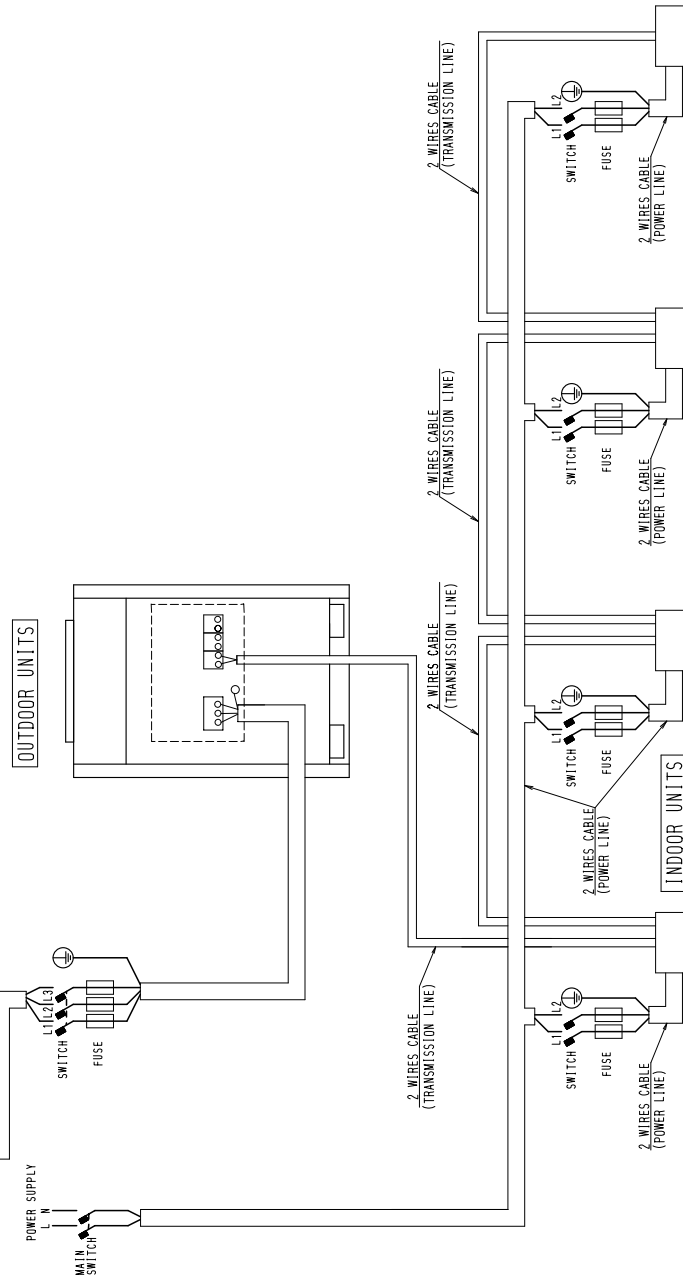

C:3D042647B

RXYQ144, 168,192MTJU

- Notes 1) All wires, components and materials to be procured on site must comply with the National Electrical Code(NEC) and applicable local codes.  
 2) Use copper conductors only.  
 3) As for details, see the wiring diagram.  
 4) Install fused disconnects per NEC for safety.  
 5) All field wires and components must be provided by a licensed electrician.
- 6) The units shall be grounded in compliance with the NEC and applicable local codes.  
 7) Wiring shown is general points-of-connection guides only and is not intended for or to include all details for the specific installation.  
 8) Be sure to install a switch and fuses to the power line of each unit.  
 9) Install a main switch that can interrupt all the power sources in an integrated manner because this system consists of the equipment utilizing the multiple power sources.  
 10) If there is a possibility of reversed phase, open phase, momentary blackout or the power goes on and off while the units are operating, attach a reversed phase protection circuit locally.  
 Operating the units in reversed phase may break the compressors and other components.

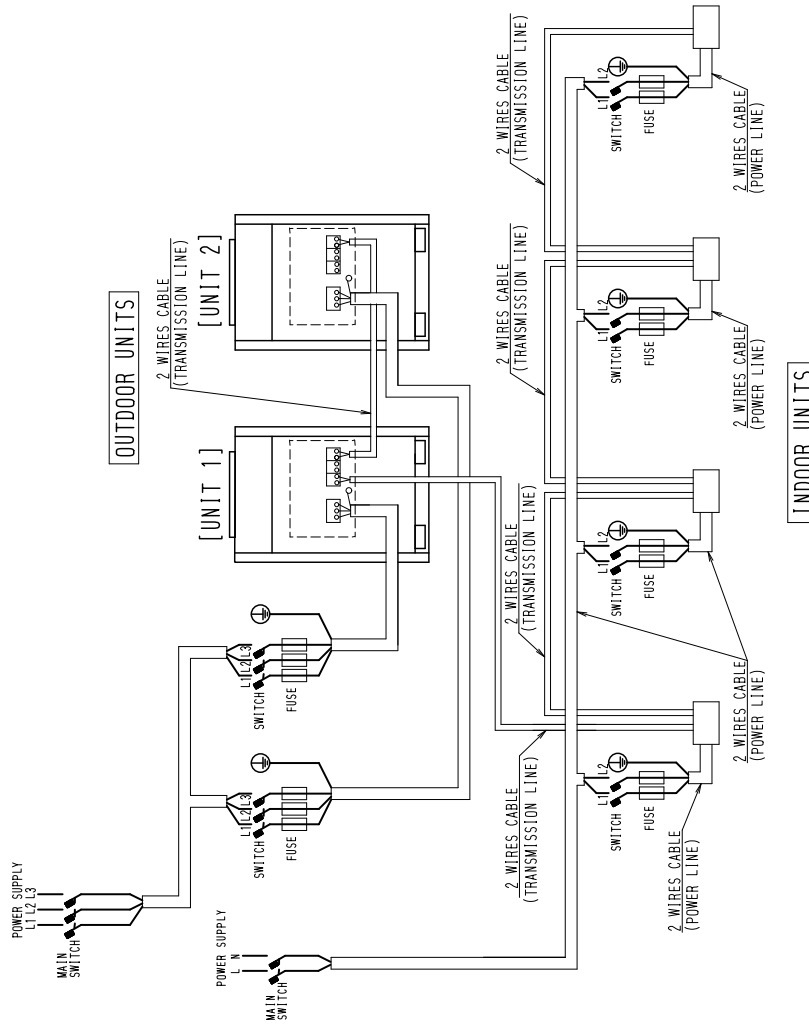

C:3D050359A

## 2.3 Indoor Unit

### FXFQ12M/18M/24M/30M/36MVJU

| INDOOR UNIT             |   | RECEIVER/DISPLAY UNIT (ATTACHED TO WIRELESS REMOTE CONTROLLER) |  |
|-------------------------|---|--|--|
| A1P                     | PRINTED CIRCUIT BOARD                                 | A2P  | PRINTED CIRCUIT BOARD                                |
| C1                      | CAPACITOR (M1F)                                       | A3P  | PRINTED CIRCUIT BOARD                                |
| F1U                     | FUSE (F5A/250V)                                       | H1P  | LIGHT EMITTING DIODE (ON-RED)                        |
| HAP                     | LIGHT EMITTING DIODE (SERVICE MONITOR-GREEN)          | H2P  | LIGHT EMITTING DIODE (TIMER-GREEN)                   |
| KPR                     | MAGNETIC RELAY (M1P)                                  | H3P  | LIGHT EMITTING DIODE (FILTER SIGN-RED)               |
| M1F                     | MOTOR (INDOOR FAN)                                    | H4P  | LIGHT EMITTING DIODE (DEFROST-ORANGE)                |
| M1P                     | MOTOR (DRAIN PUMP)                                    | SS1  | SELECTOR SWITCH (MAIN/SUB)                           |
| M1S                     | MOTOR (SWING FLAP)                                    | SS2  | SELECTOR SWITCH (ADDRESS SET)                        |
| Q1E                     | THERMO SWITCH (EMBEDDED)                              | X18A   | CONNECTOR (WIRING ADAPTOR FOR ELECTRICAL APPENDICES) |
| R1T                     | THERMISTOR (AIR)                                      | X23A   | CONNECTOR (WIRELESS REMOTE CONTROLLER)               |
| R2T-3T                  | THERMISTOR (COIL)                                     |  |  |
| S1L                     | FLOAT SWITCH  |  |  |
| T1R                     | TRANSFORMER (208-230V/25V)                            |  |  |
| V1TR                    | TRIC  |  |  |
| X1M                     | TERMINAL STRIP (POWER)                                |  |  |
| X2M                     | TERMINAL STRIP (CONTROL CONNECTOR FOR OPTIONAL PARTS) |  |  |
| Y1E                     | ELECTRONIC EXPANSION VALVE                            |  |  |
| WIRED REMOTE CONTROLLER |   |  |  |
| R1T                     | THERMISTOR (AIR)                                      |  |  |
| SS1                     | SELECTOR SWITCH (MAIN/SUB)                            |  |  |

NOTES)

1. [Symbol] : TERMINAL  
[Symbol] : CONNECTOR  
[Symbol] : FIELD WIRING
2. IN CASE USING CENTRAL REMOTE CONTROLLER, CONNECT IT TO THE UNIT IN ACCORDANCE WITH THE ATTACHED INSTRUCTION MANUAL.
3. X23A IS CONNECTED WHEN THE WIRELESS REMOTE CONTROLLER KIT IS BEING USED.
4. WHEN CONNECTING THE INPUT WIRES FROM OUTSIDE, FORCED OFF OR ON/OFF CONTROL OPERATION CAN BE SELECTED BY REMOTE CONTROLLER.  
IN DETAILS, REFER TO THE INSTALLATION MANUAL ATTACHED THE UNIT.
5. SYMBOLS SHOW AS FOLLOWS  
(BLK:BLACK BLU:BLUE ORG:ORANGE PNK:PINK  
RED:RED WHT:WHITE YLW:YELLOW)
6. USE COPPER CONDUCTORS ONLY.

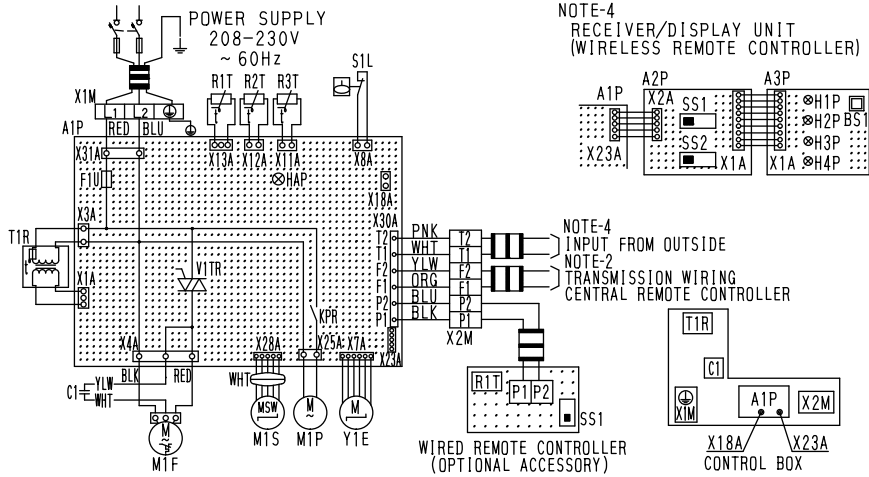

NOTE-4  
RECEIVER/DISPLAY UNIT  
(WIRELESS REMOTE CONTROLLER)

NOTE-4  
INPUT FROM OUTSIDE  
NOTE-2  
TRANSMISSION WIRING  
CENTRAL REMOTE CONTROLLER

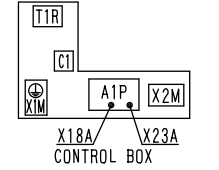

3D042620B

### FXDQ07M/09M/12M/18M/24MVJU

|                              |  |
|------------------------------|--|
| A1P                          | PRINTED CIRCUIT BOARD                                |
| C1                           | CAPACITOR (M1F)                                      |
| F1U                          | FUSE (F5A/250V)                                      |
| HAP                          | LIGHT EMITTING DIODE (SERVICE MONITOR-GREEN)         |
| KPR                          | MAGNETIC RELAY (M1P)                                 |
| M1F                          | MOTOR (INDOOR FAN)                                   |
| M1P                          | MOTOR (DRAIN PUMP)                                   |
| Q1M                          | THERMAL PROTECTOR (MIF EMBEDDED)                     |
| R1T                          | THERMISTOR (AIR)                                     |
| R2T                          | THERMISTOR (COIL-1)                                  |
| R3T                          | THERMISTOR (COIL-2)                                  |
| S1L                          | FLOAT SWITCH   |
| T1R                          | TRANSFORMER (208-230V/25V)                           |
| V1TR                         | PHASE CONTROL CIRCUIT                                |
| X1M                          | TERMINAL BLOCK                                       |
| X2M                          | TERMINAL BLOCK                                       |
| Y1E                          | ELECTRONIC EXPANSION VALVE                           |
| Z1C-Z2C                      | NOISE FILTER (FERRITE CORE)                          |
| WIRED REMOTE CONTROLLER      |  |
| R1T                          | THERMISTOR (AIR)                                     |
| SS1                          | SELECTOR SWITCH (MAIN/SUB)                           |
| CONNECTOR FOR OPTIONAL PARTS |  |
| X16A                         | CONNECTOR (ADAPTOR FOR WIRING)                       |
| X18A                         | CONNECTOR (WIRING ADAPTOR FOR ELECTRICAL APPENDICES) |

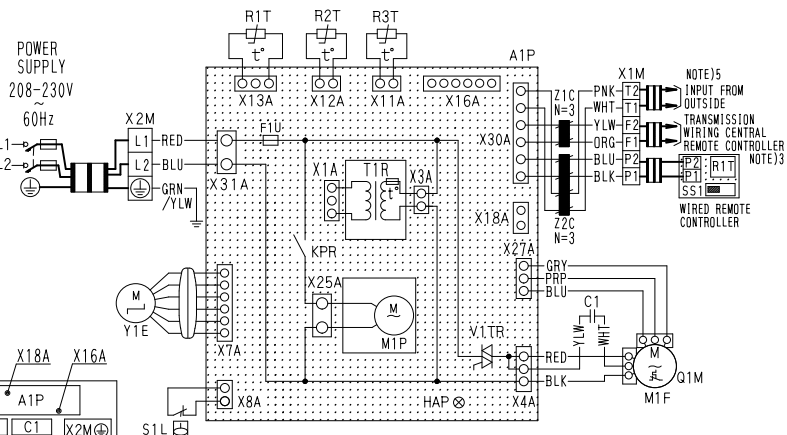

NOTES)

1. [Symbol] : TERMINAL  
[Symbol] : CONNECTOR  
[Symbol] : FIELD WIRING
2. IN CASE USING CENTRAL REMOTE CONTROLLER, CONNECT IT TO THE UNIT IN ACCORDANCE WITH THE ATTACHED INSTALLATION MANUAL.
3. REMOTE CONTROLLER MODEL VARIES ACCORDING TO THE COMBINATION SYSTEM, CONFIRM ENGINEERING MATERIALS AND CATALOGS, ETC, BEFORE CONNECTING.
4. WHEN CONNECTING THE INPUT WIRES FROM OUTSIDE, FORCED OFF OR ON/OFF CONTROL OPERATION CAN BE SELECTED BY REMOTE CONTROLLER.  
IN DETAILS, REFER TO THE INSTALLATION MANUAL ATTACHED TO THE UNIT.
5. SYMBOLS SHOW AS FOLLOWS: RED:RED BLK:BLACK WHT:WHITE YLW:YELLOW PRP:PURPLE GRP:GRAY BLU:BLUE PNK:PINK ORG:ORANGE GRN:GREEN
6. USE COPPER CONDUCTORS ONLY.

3D050501A

FXSQ12M/18M/24M/30M/36M/48MVJU

| INDOOR UNIT                                     | WIRED REMOTE CONTROLLER                                  |
|---|--|
| A1P PRINTED CIRCUIT BOARD                       | R1T THERMISTOR(A1R)                                      |
| A2P TERMINAL BOARD                              | SS1 SELECTOR SWITCH(MAIN/SUB)                            |
| C1 CAPACITOR(M1F)                               | CONNECTOR FOR OPTIONAL PARTS                             |
| F1U FUSE(5A/250V)                               | X18A CONNECTOR(WIRING ADAPTOR FOR ELECTRICAL APPENDICES) |
| HAP LIGHT EMITTING DIODE(SERVICE MONITOR GREEN) |  |
| K1R-K3R MAGNETIC RELAY(M1F)                     |  |
| KPR MAGNETIC RELAY(M1P)                         |  |
| M1F MOTOR(INDOOR FAN)                           |  |
| M1P MOTOR(DRAIN PUMP)                           |  |
| Q1M THERMO SWITCH(M1F EMBEDDED)                 |  |
| R1T THERMISTOR(A1R)                             |  |
| R2T-R3T THERMISTOR(COIL)                        |  |
| S1L FLOAT SWITCH                                |  |
| T1R TRANSFORMER(208-230V/22V)                   |  |
| X1M TERMINAL BLOCK(POWER)                       |  |
| X2M TERMINAL BLOCK(CONTROL)                     |  |
| Y1E ELECTRONIC EXPANSION VALVE                  |  |

NOTE-5

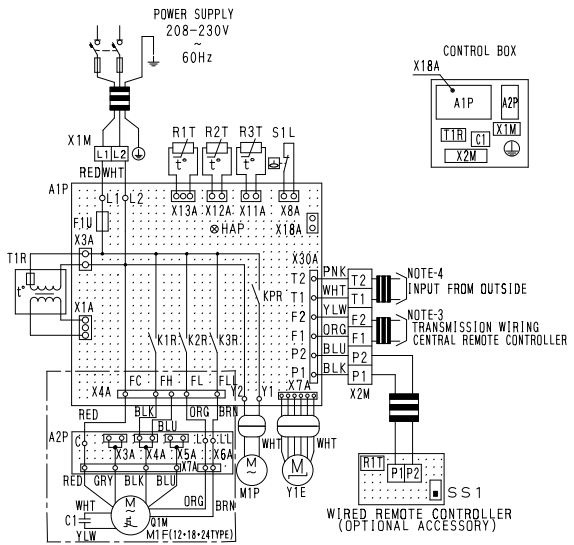
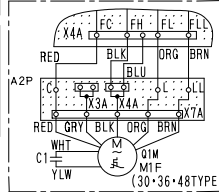
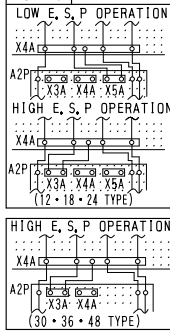

- NOTES
1. [Terminal Block Symbol] : TERMINAL BLOCK, [Connector Symbol] : CONNECTOR, [Terminal Symbol] : TERMINAL
  2. [Field Wiring Symbol] : FIELD WIRING
  3. IN CASE USING CENTRAL REMOTE CONTROLLER, CONNECT IT TO THE UNIT IN ACCORDANCE WITH THE ATTACHED INSTRUCTION MANUAL.
  4. WHEN CONNECTING THE INPUT WIRES FROM OUTSIDE, FORCED OFF OR ON/OFF CONTROL OPERATION CAN BE SELECTED BY REMOTE CONTROLLER. IN DETAILS, REFER TO THE INSTALLATION MANUAL ATTACHED THE UNIT.
  5. IN CASE HIGH OR LOW E,S,P OPERATION, CHANGE OVER THE WIRING CONNECTION FROM X4A(OF A2P) TO X3A OR X5A.
  6. SYMBOLS SHOW AS FOLLOWS. (PNK:PINK WHT:WHITE YLW:YELLOW ORG:ORANGE BLU:BLUE BLK:BLACK RED:RED BRN:BROWN)
  7. USE COPPER CONDUCTORS ONLY.

3D043177A

FXMQ30M/36M/48MVJU

| INDOOR UNIT                                     | R2T-R3T  | THERMISTOR(COIL) |
|---|--|------------------|
| A1P PRINTED CIRCUIT BOARD                       | S1L FLOAT SWITCH   |                  |
| A2P TERMINAL BOARD                              | T1R TRANSFORMER(208-230V/22V)                            |                  |
| C1 CAPACITOR(M1F)                               | X1M TERMINAL BLOCK(POWER)                                |                  |
| F1U FUSE(5A/250V)                               | X2M TERMINAL BLOCK(CONTROL)                              |                  |
| F1U FUSE(10A/250V)                              | Y1E ELECTRONIC EXPANSION VALVE                           |                  |
| HAP LIGHT EMITTING DIODE(SERVICE MONITOR-GREEN) | SS1 SELECTOR SWITCH(MAIN/SUB)                            |                  |
| K1R-K3R MAGNETIC RELAY(M1F)                     | R1T THERMISTOR(A1R)                                      |                  |
| M1F MOTOR(INDOOR FAN)                           | CONNECTOR FOR OPTIONAL PARTS                             |                  |
| Q1M THERMO SWITCH(M1F EMBEDDED)                 | X18A CONNECTOR(WIRING ADAPTOR FOR ELECTRICAL APPENDICES) |                  |
| R1T THERMISTOR(A1R)                             |  |                  |

NOTE-5

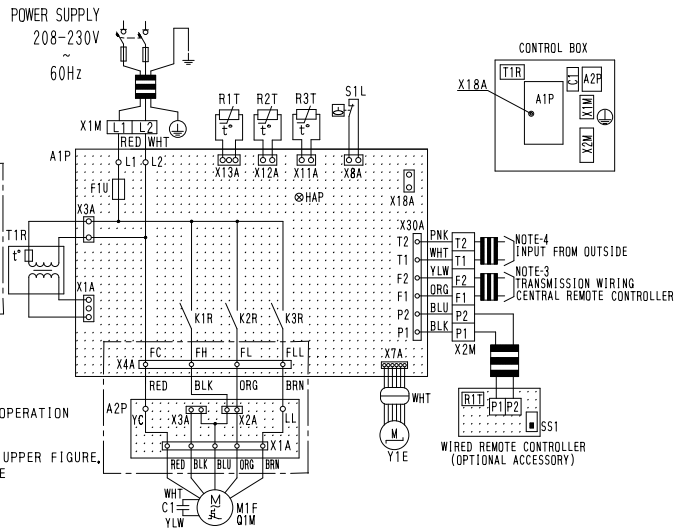
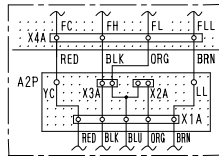

- NOTES
1. [Terminal Block Symbol] : TERMINAL BLOCK, [Connector Symbol] : CONNECTOR, [Terminal Symbol] : TERMINAL
  2. [Field Wiring Symbol] : FIELD WIRING
  3. IN CASE USING CENTRAL REMOTE CONTROLLER, CONNECT IT TO THE UNIT IN ACCORDANCE WITH THE ATTACHED INSTRUCTION MANUAL.
  4. WHEN CONNECTING THE INPUT WIRES FROM OUTSIDE, FORCED OFF OR ON/OFF CONTROL OPERATION CAN BE SELECTED BY REMOTE CONTROLLER. IN DETAILS, REFER TO THE INSTALLATION MANUAL ATTACHED THE UNIT.
  5. IN CASE HIGH E,S,P OPERATION, CHANGE OVER THE WIRING CONNECTION OF X2A AS SHOWN UPPER FIGURE.
  6. SYMBOLS SHOW AS FOLLOWS. (PNK:PINK WHT:WHITE YLW:YELLOW ORG:ORANGE BLU:BLUE BLK:BLACK RED:RED BRN:BROWN)
  7. USE COPPER CONDUCTORS ONLY.

3D043176A







## 3. List of Electrical and Functional Parts

### 3.1 Outdoor Unit

#### 3.1.1 RXYQ72M, 96MTJU

| Item                   | Name  |                               | Symbol  | Model  |
|------------------------|---|-------------------------------|---------|--|
|                        |   |                               |         | RXYQ72M, 96MTJU                                  |
| Compressor             | Inverter  | Type                          | M1C     | JT100FCVDKT@3                                    |
|                        | STD.1   | Type                          | M2C     | JT170FCKTJ@3                                     |
|                        | Crankcase heater (INV)                                |                               | E1HC    | 240V 33W   |
|                        | Crankcase heater (STD.1)                              |                               | E2HC    | 240V 33W   |
|                        | Crankcase heater (STD.2)                              |                               | E3HC    | —  |
|                        | OC protection device for STD compressor               |                               | —       | 28.8A  |
| Fan motor              | Motor   |                               | M1F     | 0.75kw   |
|                        | OC protection device                                  |                               | —       | 3.2A   |
| Functional parts       | Electronic expansion valve (Main)                     | Cooling                       | Y1E     | 0pls   |
|                        |   | Heating                       |         | PI control                                       |
|                        | Electronic expansion valve (Subcool)                  | Cooling                       | Y2E     | PI control                                       |
|                        |   | Heating                       |         | 0pls   |
|                        | Solenoid valve (Hot gas)                              |                               | Y1S     | TEV1620DQ2                                       |
|                        | Solenoid valve (External multi oil)                   |                               | Y2S     | TEV1620DQ2                                       |
|                        | Solenoid valve (Receiver gas charge)                  |                               | Y3S     | TEV1620DQ2                                       |
|                        | Solenoid valve (Receiver gas discharge)               |                               | Y4S     | VPV-603D   |
|                        | Solenoid valve (Non-operating unit gas discharge)     |                               | Y5S     | TEV1620DQ2                                       |
|                        | Solenoid valve (Non-operating unit liquid pipe close) |                               | Y6S     | VPV-803DQ50                                      |
| 4 way valve            |   | Y7S                           | VHV0404 |  |
| Pressure-related parts | Pressure switch (INV)                                 |                               | S1PH    | PS80 ON : 551+0/-21.8psi OFF : 413±21.8psi       |
|                        | Pressure switch (STD1)                                |                               | S2PH    | PS80<br>ON : 551+0/-21.8psi<br>OFF : 413±21.8psi |
|                        | Pressure switch (STD2)                                |                               | S3PH    | —  |
|                        | Fusible plug  |                               | —       | FPGD-3D 158 to 167°F                             |
|                        | Pressure sensor (HP)                                  |                               | S1NPH   | PS8051A 0 to 601.9psi                            |
|                        | Pressure sensor (LP)                                  |                               | S1NPL   | PS8051A -14.5 to 246.6psi                        |
| Thermistor             | INV PCB   | For fin                       | R1T     | 3.5 to 360Ω                                      |
|                        | Main PCB  | For outdoor air               | R1T     | 3.5 to 360Ω                                      |
|                        |   | For suction pipe              | R2T     | 3.5 to 360Ω                                      |
|                        |   | For discharge pipe (INV)      | R31T    | 3.5 to 400Ω                                      |
|                        |   | For discharge pipe (STD.1)    | R32T    | 3.5 to 400Ω                                      |
|                        |   | For discharge pipe (STD.2)    | R33T    | 3.5 to 400Ω                                      |
|                        |   | For heat exchanger            | R4T     | 3.5 to 360Ω                                      |
|                        |   | For subcooling heat exchanger | R5T     | 3.5 to 360Ω                                      |
|                        |   | For receiver liquid pipe      | R6T     | 3.5 to 360Ω                                      |
| For equalizing pipe    | R7T   | 3.5 to 360Ω                   |         |  |
| Others                 | Fuse (A1P)  |                               | F1, 2U  | 250VAC 10A Class B                               |

## 3.2 Indoor Side

### 3.2.1 Indoor Units

| Parts Name        |  | Symbol | Model                                    |                |                |                |                | Remark |
|-------------------|--|--------|--|----------------|----------------|----------------|----------------|--------|
|                   |  |        | FXFQ<br>12MVJU                           | FXFQ<br>18MVJU | FXFQ<br>24MVJU | FXFQ<br>30MVJU | FXFQ<br>36MVJU |        |
| Remote Controller | Wired Remote Controller                    |        | BRC1C71                                  |                |                |                |                | Option |
|                   | Wireless Remote Controller                 |        | BRC7C812                                 |                |                |                |                |        |
| Motors            | Fan Motor                                  | M1F    | 1φ45W 6P                                 |                |                | 1φ90W 6P       |                |        |
|                   |  |        | Thermal Protector 266°F : OFF 176°F : ON |                |                |                |                |        |
|                   | Capacitor, fan motor                       | C1     | 3.5μF 450VAC                             |                |                | 5.0μF 450VAC   |                |        |
|                   | Drain Pump                                 | M1P    | PLD-12230DM<br>Thermal Fuse 293°F        |                |                |                |                |        |
|                   | Swing Motor                                | M1S    | MP35HCA [3P007482-1]                     |                |                |                |                |        |
| Thermistors       | Thermistor (Suction Air)                   | R1T    | ST8601A-1 φ4 L250<br>20kΩ (77°F)         |                |                |                |                |        |
|                   | Thermistor (for Heat Exchanger High Temp.) | R3T    | ST8605-3 φ8 L630<br>20kΩ (77°F)          |                |                |                |                |        |
|                   | Thermistor (Heat Exchanger)                | R2T    | ST8602A-3 φ6 L630<br>20kΩ (77°F)         |                |                |                |                |        |
| Others            | Float Switch                               | S1L    | FS-0211                                  |                |                |                |                |        |
|                   | Fuse                                       | F1U    | 250V 5A φ5.2                             |                |                |                |                |        |
|                   | Transformer                                | T1R    | TR25H25R0                                |                |                |                |                |        |

| Parts Name        |  | Symbol | Model   |                |                |                |                | Remark |
|-------------------|--|--------|---|----------------|----------------|----------------|----------------|--------|
|                   |  |        | FXDQ<br>07MVJU                                | FXDQ<br>09MVJU | FXDQ<br>12MVJU | FXDQ<br>18MVJU | FXDQ<br>24MVJU |        |
| Remote Controller | Wired Remote Controller                    |        | BRC1C71                                       |                |                |                |                | Option |
|                   | Wireless Remote Controller                 |        | BRC4C82                                       |                |                |                |                |        |
| Motors            | Fan Motor                                  | M1F    | 1φ62W 4P                                      |                |                | 1φ13W 4P       |                |        |
|                   |  |        | Thermal Protector 266±9°F : OFF 181±27°F : ON |                |                |                |                |        |
|                   | Capacitor, fan motor                       | C1     | 4.0μF 450VAC                                  |                |                | 7.0μF 450VAC   |                |        |
| Thermistors       | Thermistor (Suction Air)                   | R1T    | ST8601A-1 φ4 L250<br>20kΩ (77°F)              |                |                |                |                |        |
|                   | Thermistor (for Heat Exchanger High Temp.) | R3T    | ST8605-4 φ8 L800<br>20kΩ (77°F)               |                |                |                |                |        |
|                   | Thermistor (Heat Exchanger)                | R2T    | ST8602A-4 φ6 L800<br>20kΩ (77°F)              |                |                |                |                |        |
| Others            | Float Switch                               | S1L    | FS-0211                                       |                |                |                |                |        |
|                   | Transformer                                | T1R    | TR25H25R0                                     |                |                |                |                |        |

| Parts Name        |  | Symbol | Model                             |                |                |  |                |                | Remark |
|-------------------|--|--------|-----------------------------------|----------------|----------------|--|----------------|----------------|--------|
|                   |  |        | FXSQ<br>12MVJU                    | FXSQ<br>18MVJU | FXSQ<br>24MVJU | FXSQ<br>30MVJU                             | FXSQ<br>36MVJU | FXSQ<br>48MVJU |        |
| Remote Controller | Wired Remote Controller                    |        | BRC1C71                           |                |                |  |                |                | Option |
|                   | Wireless Remote Controller                 |        | BRC4C82                           |                |                |  |                |                |        |
| Motors            | Fan Motor                                  | M1F    | 1φ50W 4P                          | 1φ85W 4P       | 1φ125W 4P      | 1φ225W 4P                                  |                |                |        |
|                   | Drain Pump                                 | M1P    | Thermal Fuse 305.6°F              |                |                | Thermal protector 275°F : OFF 188.6°F : ON |                |                |        |
| Thermistors       | Thermistor (Suction Air)                   | R1T    | ST8601-13 φ4 L630<br>20kΩ (77°F)  |                |                |  |                |                |        |
|                   | Thermistor (for Heat Exchanger High Temp.) | R3T    | ST8605-7 φ8 L1600<br>20kΩ (77°F)  |                |                |  |                |                |        |
|                   | Thermistor (Heat Exchanger)                | R2T    | ST8602A-7 φ6 L1600<br>20kΩ (77°F) |                |                |  |                |                |        |
| Others            | Float Switch                               | S1L    | FS-0211                           |                |                |  |                |                |        |
|                   | Fuse                                       | F1U    | 250V 5A φ5.2                      |                |                |  |                |                |        |
|                   | Transformer                                | T1R    | TR25H25R0                         |                |                |  |                |                |        |

| Parts Name        |  | Symbol | Model                             |                |                | Remark |
|-------------------|--|--------|-----------------------------------|----------------|----------------|--------|
|                   |  |        | FXMQ<br>30MVJU                    | FXMQ<br>36MVJU | FXMQ<br>48MVJU |        |
| Remote Controller | Wired Remote Controller                    |        | BRC1C71                           |                |                | Option |
|                   | Wireless Remote Controller                 |        | BRC4C82                           |                |                |        |
| Motors            | Fan Motor                                  | M1F    | 1φ160W                            | 1φ270W         | 1φ430W         |        |
|                   | Capacitor for Fan Motor                    | C1R    | 6μF 450V                          | 9μF 450V       | 8μF 450V       |        |
| Thermistors       | Thermistor (Suction Air)                   | R1T    | ST8601A-5 φ4 L1000<br>20kΩ (77°F) |                |                |        |
|                   | Thermistor (for Heat Exchanger High Temp.) | R3T    | ST8605A-4 φ8 L800<br>20kΩ (77°F)  |                |                |        |
|                   | Thermistor (Heat Exchanger)                | R2T    | ST8602A-4 φ6 L800<br>20kΩ (77°F)  |                |                |        |
| Others            | Float switch                               | S1L    | FS-0211                           |                |                |        |
|                   | Fuse                                       | F1U    | 250V 5A φ5.2                      | 250V 10A φ5.2  |                |        |
|                   | Transformer                                | T1R    | TR25H25R0                         |                |                |        |

| Parts Name        |  | Symbol | Model                                    |                                      |                | Remark |
|-------------------|--|--------|--|--------------------------------------|----------------|--------|
|                   |  |        | FXHQ<br>12MVJU                           | FXHQ<br>24MVJU                       | FXHQ<br>36MVJU |        |
| Remote Controller | Wired Remote Controller                    |        | BRC1C71                                  |                                      |                | Option |
|                   | Wireless Controller                        |        | BRC7E83                                  |                                      |                |        |
| Motors            | Fan Motor                                  | M1F    | 1φ63W                                    | 1φ130W                               |                |        |
|                   |  |        | Thermal protector 266°F : OFF 176°F : ON |                                      |                |        |
|                   | Capacitor for Fan Motor                    | C1R    | 3.0μF-450V                               | 9.0μF-450V                           |                |        |
|                   | Swing Motor                                | M1S    | MT8-L[3P058751-1]<br>AC200~240V          |                                      |                |        |
| Thermistors       | Thermistor (Suction Air)                   | R1T    | ST8601A-1 φ4 L250<br>20kΩ (77°F)         |                                      |                |        |
|                   | Thermistor (for Heat Exchanger High Temp.) | R3T    | ST8605-6 φ8 L = 1250<br>20kΩ (77°F)      | ST8605-6 φ8 L = 1250<br>20kΩ (77°F)  |                |        |
|                   | Thermistor (Heat Exchanger)                | R2T    | ST8602A-6 φ6 L = 1250<br>20kΩ (77°F)     | ST8602A-6 φ6 L = 1250<br>20kΩ (77°F) |                |        |
| Others            | Fuse                                       | F1U    | 250V 5A                                  |                                      |                |        |
|                   | Transformer                                | T1R    | TR25H25R0                                |                                      |                |        |

| Parts Name        |  | Symbol | Model                                    |                |                                       |                |                | Remark |
|-------------------|--|--------|--|----------------|---------------------------------------|----------------|----------------|--------|
|                   |  |        | FXAQ<br>07MVJU                           | FXAQ<br>09MVJU | FXAQ<br>12MVJU                        | FXAQ<br>18MVJU | FXAQ<br>24MVJU |        |
| Remote Controller | Wired Remote Controller                    |        | BRC1C71                                  |                |                                       |                |                | Option |
|                   | Wireless Remote Controller                 |        | BRC7E818                                 |                |                                       |                |                | Option |
| Motors            | Fan Motor                                  | M1F    | 1φ40W                                    |                | 1φ43W                                 |                |                |        |
|                   |  |        | Thermal protector 266°F : OFF 176°F : ON |                |                                       |                |                |        |
|                   | Swing Motor                                | M1S    | MP24[3SB40333-1]<br>AC200~240V           |                | MSFBC20C21 [3SB40550-1]<br>AC200~240V |                |                |        |
| Thermistors       | Thermistor (Suction Air)                   | R1T    | ST8601-2 φ4 L400<br>20kΩ (77°F)          |                |                                       |                |                |        |
|                   | Thermistor (for Heat Exchanger High Temp.) | R3T    | ST8605-2 φ8 L400<br>20kΩ (77°F)          |                |                                       |                |                |        |
|                   | Thermistor (for Heat Exchanger)            | R2T    | ST8602-2 φ6 L400<br>20kΩ (77°F)          |                |                                       |                |                |        |
| Others            | Float Switch                               | S1L    | OPTION                                   |                |                                       |                |                |        |
|                   | Fuse                                       | F1U    | 250V 3.15A                               |                |                                       |                |                |        |

| Parts Name        |  | Symbol | Model                                    |                |                | Remark |
|-------------------|--|--------|--|----------------|----------------|--------|
|                   |  |        | FXLQ<br>12MVJU                           | FXLQ<br>18MVJU | FXLQ<br>24MVJU |        |
| Remote Controller | Wired Remote Controller                    |        | BRC1C71                                  |                |                | Option |
|                   | Wireless Remote Controller                 |        | —  |                |                |        |
| Motors            | Fan Motor                                  | M1F    | 1φ25W                                    | 1φ35W          |                |        |
|                   |  |        | Thermal protector 275°F : OFF 248°F : ON |                |                |        |
|                   | Capacitor for Fan Motor                    | C1R    | 0.5μF-450V                               | 1.5μF-450V     | 2.0μF-450V     |        |
| Thermistors       | Thermistor (Suction Air)                   | R1T    | ST8601-6 φ4 L1250<br>20kΩ (77°F)         |                |                |        |
|                   | Thermistor (for Heat Exchanger High Temp.) | R3T    | ST8605-9 φ8 L2500<br>20kΩ (77°F)         |                |                |        |
|                   | Thermistor (for Heat Exchanger)            | R2T    | ST8602A-9 φ6 L2500<br>20kΩ (77°F)        |                |                |        |
| Others            | Fuse                                       | F1U    | AC250V 5A                                |                |                |        |
|                   | Transformer                                | T1R    | TR25H25R0                                |                |                |        |

| Parts Name           |   | Symbol | Model   |                  |                  | Remark |
|----------------------|---|--------|---|------------------|------------------|--------|
|                      |   |        | FXNQ<br>12MVJU                                  | FXNQ<br>18MVJU   | FXNQ<br>24MVJU   |        |
| Remote<br>Controller | Wired Remote<br>Controller                    |        | BRC1C71   |                  |                  | Option |
|                      | Wireless Remote<br>Controller                 |        | —   |                  |                  |        |
| Motors               | Fan Motor                                     | M1F    | 1 $\phi$ 25W                                    | 1 $\phi$ 35W     |                  |        |
|                      | Capacitor for Fan Motor                       | C1R    | 0.5 $\mu$ F-450V                                | 1.5 $\mu$ F-450V | 2.0 $\mu$ F-450V |        |
| Thermistors          | Thermistor (Suction Air)                      | R1T    | ST8601-6 $\phi$ 4 L1250<br>20k $\Omega$ (77°F)  |                  |                  |        |
|                      | Thermistor (for Heat<br>Exchanger High Temp.) | R3T    | ST8605-9 $\phi$ 8 L2500<br>20k $\Omega$ (77°F)  |                  |                  |        |
|                      | Thermistor (for Heat<br>Exchanger)            | R2T    | ST8602A-9 $\phi$ 6 L2500<br>20k $\Omega$ (77°F) |                  |                  |        |
| Others               | Fuse  | F1U    | AC250V 5A                                       |                  |                  |        |
|                      | Transformer                                   | T1R    | TR25H25R0                                       |                  |                  |        |

## 4. Option List

### 4.1 Option List of Controllers

#### Optional Accessories of Operation Control System

| No. | Item   | Type       | FXFQ~MVJU | FXSQ~MVJU | FXMQ~MVJU | FXAQ~MVJU | FXLQ~MVJU<br>FXNQ~MVJU | FXHQ~MVJU  | FXDQ~MVJU  |
|-----|--|------------|-----------|-----------|-----------|-----------|------------------------|------------|------------|
| 1   | Remote controller                            | Wireless   | BRC7C812  | BRC4C82   |           | BRC7E818  | —                      | BRC7E83    | BRC4C82    |
|     |  | Wired      |           |           | BRC1C71   |           | BRC1D71                |            |            |
| 2   | Set back time clock                          |            |           |           |           | BRC15A71  |                        |            |            |
| 3   | Remote sensor                                |            |           |           |           | KRCS01-1  |                        |            |            |
| 4   | Installation box for adaptor PCB             | KRP1B98    | —         |           |           |           | KRP1C93                | KRP1B101   |            |
| 5   | Central remote controller                    |            |           |           |           | DCS302C71 |                        |            |            |
| 5-1 | Electrical box                               |            |           |           |           | KJB311A   |                        |            |            |
| 6   | Unified on/off controller                    |            |           |           |           | DCS301C71 |                        |            |            |
| 6-1 | Electrical box                               |            |           |           |           | KJB212A   |                        |            |            |
| 7   | Schedule timer                               |            |           |           |           | DST301B61 |                        |            |            |
| 8   | External control adaptor for outdoor unit    | ★DTA104A62 | DTA104A61 |           | —         |           | DTA104A61              | ★DTA104A62 | ★DTA104A53 |
| 9   | D3-NET Expander adaptor                      |            |           |           |           | DTA109A51 |                        |            |            |
| 10  | Simplified remote controller                 | —          | BRC2A71   |           | —         |           | BRC2A71                | —          | BRC2A71    |
| 11  | Adaptor for wiring                           | ★KRP1B72   |           |           | KRP1B71   |           | ★KRP1B73               |            | —          |
| 12  | Wiring adaptor for electrical appendices (2) | ★KRP4A73   |           |           | KRP4A71   |           | ★KRP4A72               |            | ★KRP4A74   |

C:3D043022D

#### Notes:

1. Installation box (No.4) is necessary for each adaptor marked ★.
2. Electrical box (5-1/6-1) is required for controller (No. 5/6).

#### Building management system

|                              | Part name  |          |                              | Model No.         | Function  |
|------------------------------|--|----------|------------------------------|-------------------|---|
| Intelligent Touch Controller | basic  | Hardware | intelligent Touch Controller | DCS601C71         | • Air-Conditioning management system that can be controlled by a compact all-in-one unit.   |
|                              | Option   | Software | Web                          | DCS004A71         | • Monitors and controls the air conditioning system using the Internet and Web browser application on a PC.                                       |
| Communication Line           | *2 Interface for use in BACnet®  |          |                              | DMS502A71         | Interface unit to allow communications between VRV and BMS. Operation and monitoring of air-conditioning systems through BACnet® communications.  |
|                              | Optional DIII board  |          |                              | DAM411A1          | Expansion kit, installed on DMS502A71, to provide 3 more DIII-NET communication ports. Not usable independently.                                  |
|                              | Optional Di board  |          |                              | DAM412A1          | Expansion kit, installed on DMS502A71, to provide 16 more wattmeter pulse input points. Not usable independently.                                 |
|                              | *3 Interface for use in LONWORKS®  |          |                              | DMS504B71         | Interface unit to allow communications between VRV and BMS. Operation and monitoring of air-conditioning systems through LONWORKS® communication. |
| Contact/Analog signal        | Unification adaptor for computerized control                                   |          |                              | DCS302A72         | Interface between the central monitoring board and central control units  |
|                              | Wiring adaptor for electrical appendices (2)                                   |          |                              | KRP4A71-74        | To control the group of indoor units collectively, which are connected by the transmission wiring of remote controller.                           |
|                              | External control adaptor for outdoor unit (Must be installed on indoor units.) |          |                              | DTA104A53, 61, 62 | Cooling/Heating mode change over. Demand control and Low noise control are available between the plural outdoor units.                            |

#### Notes:

- ★1. BACnet® is a registered trademark of American Society of Heating, Refrigerating and Air-Conditioning Engineers (ASHRAE).
- ★2. LonWorks® is a registered trade mark of Echelon Corporation.

## 4.2 Option Lists (Outdoor Unit)

### RXYQ72, 96, 144, 168, 192MTJU

| Optional accessories                     |               | Series    | INVERTER "M" SERIES (Heat Pump Type)                    |  |
|--|---------------|-----------|---|--|
|  |               | Models    | RXYQ72, 96MTJU  | RXYQ144, 168, 192MTJU  |
| Cool/Heat Selector                       |               | KRC19-26A |   |  |
| Cool/Heat Selector                       | Fixing box    | Model     | KJB111A   |  |
| Distributive piping                      | REFNET header | Model     | KHRP26M22H KHRP26M33H<br>(Max.4 branch), (Max.8 branch) | KHRP26M22H KHRP26M33H KHRP26M72H<br>(Max.4 branch), (Max.8 branch), (Max.8 branch) |
|  | REFNET joint  | Model     | KHRP26M22T, KHRP26M33T                                  | KHRP26M22T, KHRP26M33T, KHRP26M72TU  |
| Outdoor unit multi connection piping kit |               | Model     | —   | BHFP22M90U   |

3D042655B

# 5. Example of Connection

1 indoor unit

REFNET joint

REFNET header

|   |  | Branch with REFNET joint  | Branch with REFNET joint and REFNET header  | Branch with REFNET header  |                            |                             |                 |                         |                 |                                     |                 |                         |                     |                 |                 |  |        |      |       |        |      |  |  |  |  |  |      |  |  |  |  |  |  |  |  |  |  |
|---|--|---|---|--|----------------------------|-----------------------------|-----------------|-------------------------|-----------------|-------------------------------------|-----------------|-------------------------|---------------------|-----------------|-----------------|--|--------|------|-------|--------|------|--|--|--|--|--|------|--|--|--|--|--|--|--|--|--|--|
|   | One outdoor unit installed   |   |   |  |                            |                             |                 |                         |                 |                                     |                 |                         |                     |                 |                 |  |        |      |       |        |      |  |  |  |  |  |      |  |  |  |  |  |  |  |  |  |  |
|   | Multiple outdoor units installed   |   |   |  |                            |                             |                 |                         |                 |                                     |                 |                         |                     |                 |                 |  |        |      |       |        |      |  |  |  |  |  |      |  |  |  |  |  |  |  |  |  |  |
| * In case of multiple outdoor units installed, re-read to the first outdoor branch as seen from the indoor unit.  |  |   |   |  |                            |                             |                 |                         |                 |                                     |                 |                         |                     |                 |                 |  |        |      |       |        |      |  |  |  |  |  |      |  |  |  |  |  |  |  |  |  |  |
| Maximum allowable length  | Between outdoor and indoor units   | Actual pipe length: Pipe length between outdoor and indoor units ≤ 490ft.<br>Example unit 8: a + b + c + d + e + f + g + p ≤ 490ft.   |   |  |                            |                             |                 |                         |                 |                                     |                 |                         |                     |                 |                 |  |        |      |       |        |      |  |  |  |  |  |      |  |  |  |  |  |  |  |  |  |  |
|   |  | Equivalent length: Equivalent pipe length between outdoor and indoor units ≤ 575ft. (assume equivalent pipe length of REFNET joint to be 1.6ft., that of REFNET header to be 3.3ft. calculation purposes)   |   |  |                            |                             |                 |                         |                 |                                     |                 |                         |                     |                 |                 |  |        |      |       |        |      |  |  |  |  |  |      |  |  |  |  |  |  |  |  |  |  |
|   |  | Total extension length: Total piping length from outdoor unit* to all indoor units ≤ 950ft.   |   |  |                            |                             |                 |                         |                 |                                     |                 |                         |                     |                 |                 |  |        |      |       |        |      |  |  |  |  |  |      |  |  |  |  |  |  |  |  |  |  |
| Allowable height length   | Between outdoor branch and indoor unit (Only for multiple outdoor units) | Actual pipe length: Piping length from outdoor branch to outdoor unit ≤ 33ft. Approximately length: max 43ft.   |   |  |                            |                             |                 |                         |                 |                                     |                 |                         |                     |                 |                 |  |        |      |       |        |      |  |  |  |  |  |      |  |  |  |  |  |  |  |  |  |  |
|   | Between outdoor and indoor units   | Difference in height: Difference in height between outdoor and indoor units (H1) ≤ 164ft. (Max 130ft. if the outdoor unit is below)   |   |  |                            |                             |                 |                         |                 |                                     |                 |                         |                     |                 |                 |  |        |      |       |        |      |  |  |  |  |  |      |  |  |  |  |  |  |  |  |  |  |
|   | Between indoor and indoor units  | Difference in height: Difference in height between adjacent indoor units (H2) ≤ 49ft.   |   |  |                            |                             |                 |                         |                 |                                     |                 |                         |                     |                 |                 |  |        |      |       |        |      |  |  |  |  |  |      |  |  |  |  |  |  |  |  |  |  |
| Allowable length after the branch   | Between outdoor and outdoor units  | Difference in height: Difference in height between outdoor unit (main) and outdoor unit (sub) (H3) ≤ 16ft.  |   |  |                            |                             |                 |                         |                 |                                     |                 |                         |                     |                 |                 |  |        |      |       |        |      |  |  |  |  |  |      |  |  |  |  |  |  |  |  |  |  |
|   | Actual pipe length   | Pipe length from first refrigerant branch kit (either REFNET joint or REFNET header) to indoor unit ≤ 130ft.<br>Example unit 8: b + c + d + e + f + g + p ≤ 130ft. Example unit 6: b + h ≤ 130ft., unit 8: i + k ≤ 130ft. Example unit 8: i ≤ 130ft.  |   |  |                            |                             |                 |                         |                 |                                     |                 |                         |                     |                 |                 |  |        |      |       |        |      |  |  |  |  |  |      |  |  |  |  |  |  |  |  |  |  |
| Refrigerant branch kit selection  |  | How to select the REFNET joint<br>• When using REFNET joints at the first branch counted from the outdoor unit side, choose from the following table in accordance with the capacity of the outdoor unit.   |   |  |                            |                             |                 |                         |                 |                                     |                 |                         |                     |                 |                 |  |        |      |       |        |      |  |  |  |  |  |      |  |  |  |  |  |  |  |  |  |  |
| Refrigerant branch kits can only be used with R-410A.   |  | <table border="1" style="width: 100%; border-collapse: collapse; font-size: x-small;"> <thead> <tr> <th>Outdoor unit capacity type</th> <th>Refrigerant branch kit name</th> </tr> </thead> <tbody> <tr> <td>RXYQ72/96</td> <td>KHRP26M22T, KHRP26M33T</td> </tr> <tr> <td>RXYQ144/168/192</td> <td>KHRP26M22T, KHRP26M33T, KHRP26M72TU</td> </tr> </tbody> </table>  |   |  | Outdoor unit capacity type | Refrigerant branch kit name | RXYQ72/96       | KHRP26M22T, KHRP26M33T  | RXYQ144/168/192 | KHRP26M22T, KHRP26M33T, KHRP26M72TU |                 |                         |                     |                 |                 |  |        |      |       |        |      |  |  |  |  |  |      |  |  |  |  |  |  |  |  |  |  |
| Outdoor unit capacity type  | Refrigerant branch kit name  |   |   |  |                            |                             |                 |                         |                 |                                     |                 |                         |                     |                 |                 |  |        |      |       |        |      |  |  |  |  |  |      |  |  |  |  |  |  |  |  |  |  |
| RXYQ72/96   | KHRP26M22T, KHRP26M33T   |   |   |  |                            |                             |                 |                         |                 |                                     |                 |                         |                     |                 |                 |  |        |      |       |        |      |  |  |  |  |  |      |  |  |  |  |  |  |  |  |  |  |
| RXYQ144/168/192   | KHRP26M22T, KHRP26M33T, KHRP26M72TU                                      |   |   |  |                            |                             |                 |                         |                 |                                     |                 |                         |                     |                 |                 |  |        |      |       |        |      |  |  |  |  |  |      |  |  |  |  |  |  |  |  |  |  |
|   |  | • For REFNET joints other than the first branch, select the proper branch kit model based on the total capacity index.  |   |  |                            |                             |                 |                         |                 |                                     |                 |                         |                     |                 |                 |  |        |      |       |        |      |  |  |  |  |  |      |  |  |  |  |  |  |  |  |  |  |
|   |  | <table border="1" style="width: 100%; border-collapse: collapse; font-size: x-small;"> <thead> <tr> <th>indoor capacity index</th> <th>Refrigerant branch kit name</th> </tr> </thead> <tbody> <tr> <td>&lt; 72</td> <td>KHRP26M22T</td> </tr> <tr> <td>72 ≤ x &lt; 111</td> <td>KHRP26M33T</td> </tr> <tr> <td>111 ≤</td> <td>KHRP26M72TU</td> </tr> </tbody> </table>   |   |  | indoor capacity index      | Refrigerant branch kit name | < 72            | KHRP26M22T              | 72 ≤ x < 111    | KHRP26M33T                          | 111 ≤           | KHRP26M72TU             |                     |                 |                 |  |        |      |       |        |      |  |  |  |  |  |      |  |  |  |  |  |  |  |  |  |  |
| indoor capacity index   | Refrigerant branch kit name  |   |   |  |                            |                             |                 |                         |                 |                                     |                 |                         |                     |                 |                 |  |        |      |       |        |      |  |  |  |  |  |      |  |  |  |  |  |  |  |  |  |  |
| < 72  | KHRP26M22T   |   |   |  |                            |                             |                 |                         |                 |                                     |                 |                         |                     |                 |                 |  |        |      |       |        |      |  |  |  |  |  |      |  |  |  |  |  |  |  |  |  |  |
| 72 ≤ x < 111  | KHRP26M33T   |   |   |  |                            |                             |                 |                         |                 |                                     |                 |                         |                     |                 |                 |  |        |      |       |        |      |  |  |  |  |  |      |  |  |  |  |  |  |  |  |  |  |
| 111 ≤   | KHRP26M72TU  |   |   |  |                            |                             |                 |                         |                 |                                     |                 |                         |                     |                 |                 |  |        |      |       |        |      |  |  |  |  |  |      |  |  |  |  |  |  |  |  |  |  |
|   |  | How to select the REFNET header<br>• Choose from the following table in accordance with the total capacity of all the indoor units connected below the REFNET header.   |   |  |                            |                             |                 |                         |                 |                                     |                 |                         |                     |                 |                 |  |        |      |       |        |      |  |  |  |  |  |      |  |  |  |  |  |  |  |  |  |  |
|   |  | <table border="1" style="width: 100%; border-collapse: collapse; font-size: x-small;"> <thead> <tr> <th>indoor capacity index</th> <th>Refrigerant branch kit name</th> </tr> </thead> <tbody> <tr> <td>&lt; 72</td> <td>KHRP26M22H (Max. 4 kit)</td> </tr> <tr> <td>&lt; 111</td> <td>KHRP26M33H (Max. 8 kit)</td> </tr> <tr> <td>111 ≤</td> <td>KHRP26M72H (Max. 8 kit)</td> </tr> </tbody> </table>  |   |  | indoor capacity index      | Refrigerant branch kit name | < 72            | KHRP26M22H (Max. 4 kit) | < 111           | KHRP26M33H (Max. 8 kit)             | 111 ≤           | KHRP26M72H (Max. 8 kit) |                     |                 |                 |  |        |      |       |        |      |  |  |  |  |  |      |  |  |  |  |  |  |  |  |  |  |
| indoor capacity index   | Refrigerant branch kit name  |   |   |  |                            |                             |                 |                         |                 |                                     |                 |                         |                     |                 |                 |  |        |      |       |        |      |  |  |  |  |  |      |  |  |  |  |  |  |  |  |  |  |
| < 72  | KHRP26M22H (Max. 4 kit)  |   |   |  |                            |                             |                 |                         |                 |                                     |                 |                         |                     |                 |                 |  |        |      |       |        |      |  |  |  |  |  |      |  |  |  |  |  |  |  |  |  |  |
| < 111   | KHRP26M33H (Max. 8 kit)  |   |   |  |                            |                             |                 |                         |                 |                                     |                 |                         |                     |                 |                 |  |        |      |       |        |      |  |  |  |  |  |      |  |  |  |  |  |  |  |  |  |  |
| 111 ≤   | KHRP26M72H (Max. 8 kit)  |   |   |  |                            |                             |                 |                         |                 |                                     |                 |                         |                     |                 |                 |  |        |      |       |        |      |  |  |  |  |  |      |  |  |  |  |  |  |  |  |  |  |
|   |  | In case of multiple outdoor units installed, use outdoor branch kit.  |   |  |                            |                             |                 |                         |                 |                                     |                 |                         |                     |                 |                 |  |        |      |       |        |      |  |  |  |  |  |      |  |  |  |  |  |  |  |  |  |  |
|   |  | <table border="1" style="width: 100%; border-collapse: collapse; font-size: x-small;"> <thead> <tr> <th>Number of outdoor units</th> <th>Branch kit name</th> </tr> </thead> <tbody> <tr> <td>2 units</td> <td>BHFP22M90U</td> </tr> </tbody> </table>  |   |  | Number of outdoor units    | Branch kit name             | 2 units         | BHFP22M90U              |                 |                                     |                 |                         |                     |                 |                 |  |        |      |       |        |      |  |  |  |  |  |      |  |  |  |  |  |  |  |  |  |  |
| Number of outdoor units   | Branch kit name  |   |   |  |                            |                             |                 |                         |                 |                                     |                 |                         |                     |                 |                 |  |        |      |       |        |      |  |  |  |  |  |      |  |  |  |  |  |  |  |  |  |  |
| 2 units   | BHFP22M90U   |   |   |  |                            |                             |                 |                         |                 |                                     |                 |                         |                     |                 |                 |  |        |      |       |        |      |  |  |  |  |  |      |  |  |  |  |  |  |  |  |  |  |
| Example of downstream indoor units  |  | example in case of REFNET joint C; indoor units 3 + 4 + 5 + 6 + 7 + 8   | example in case of REFNET joint B indoor units 7 + 8, example in case of REFNET header; indoor units 1 + 2 + 3 + 4 + 5 + 6  | example in case of REFNET header; indoor units 1 + 2 + 3 + 4 + 5 + 6 + 7 + 8 |                            |                             |                 |                         |                 |                                     |                 |                         |                     |                 |                 |  |        |      |       |        |      |  |  |  |  |  |      |  |  |  |  |  |  |  |  |  |  |
| Pipe size selection   |  | Piping between outdoor units and refrigerant branch kit (part A)<br>• Match to the size of the connection piping on the outdoor unit.   |   |  |                            |                             |                 |                         |                 |                                     |                 |                         |                     |                 |                 |  |        |      |       |        |      |  |  |  |  |  |      |  |  |  |  |  |  |  |  |  |  |
| <b>Caution</b><br>The thickness and material shall be selected in accordance with local code. For an outdoor unit multi installation, make the settings in accordance with the following figure.  |  | Outdoor unit connection piping size (Unit: in.)   |   |  |                            |                             |                 |                         |                 |                                     |                 |                         |                     |                 |                 |  |        |      |       |        |      |  |  |  |  |  |      |  |  |  |  |  |  |  |  |  |  |
|   |  | <table border="1" style="width: 100%; border-collapse: collapse; font-size: x-small;"> <thead> <tr> <th rowspan="2">Outdoor unit capacity type</th> <th colspan="2">Piping size</th> </tr> <tr> <th>Gas pipe</th> <th>Liquid pipe</th> </tr> </thead> <tbody> <tr> <td>RXYQ72</td> <td>φ3/4</td> <td>φ3/8</td> </tr> <tr> <td>RXYQ96</td> <td>φ7/8</td> <td>φ3/8</td> </tr> <tr> <td>RXYQ144/168/192</td> <td>φ1-1/8</td> <td>φ5/8</td> </tr> </tbody> </table>   |   |  | Outdoor unit capacity type | Piping size                 |                 | Gas pipe                | Liquid pipe     | RXYQ72                              | φ3/4            | φ3/8                    | RXYQ96              | φ7/8            | φ3/8            | RXYQ144/168/192  | φ1-1/8 | φ5/8 |       |        |      |  |  |  |  |  |      |  |  |  |  |  |  |  |  |  |  |
|   |  | Outdoor unit capacity type  | Piping size   |  |                            |                             |                 |                         |                 |                                     |                 |                         |                     |                 |                 |  |        |      |       |        |      |  |  |  |  |  |      |  |  |  |  |  |  |  |  |  |  |
| Gas pipe  | Liquid pipe  |   |   |  |                            |                             |                 |                         |                 |                                     |                 |                         |                     |                 |                 |  |        |      |       |        |      |  |  |  |  |  |      |  |  |  |  |  |  |  |  |  |  |
| RXYQ72  | φ3/4   | φ3/8  |   |  |                            |                             |                 |                         |                 |                                     |                 |                         |                     |                 |                 |  |        |      |       |        |      |  |  |  |  |  |      |  |  |  |  |  |  |  |  |  |  |
| RXYQ96  | φ7/8   | φ3/8  |   |  |                            |                             |                 |                         |                 |                                     |                 |                         |                     |                 |                 |  |        |      |       |        |      |  |  |  |  |  |      |  |  |  |  |  |  |  |  |  |  |
| RXYQ144/168/192   | φ1-1/8   | φ5/8  |   |  |                            |                             |                 |                         |                 |                                     |                 |                         |                     |                 |                 |  |        |      |       |        |      |  |  |  |  |  |      |  |  |  |  |  |  |  |  |  |  |
| Piping between refrigerant branch kits<br>• Choose from the following table in accordance with the total capacity of all the indoor units connected below this.<br>• Do not let the connection piping exceed the refrigerant piping size chosen by general system model name. |  |   | (Unit: in.)   |  |                            |                             |                 |                         |                 |                                     |                 |                         |                     |                 |                 |  |        |      |       |        |      |  |  |  |  |  |      |  |  |  |  |  |  |  |  |  |  |
|   |  |   | <table border="1" style="width: 100%; border-collapse: collapse; font-size: x-small;"> <thead> <tr> <th rowspan="2">indoor capacity index</th> <th colspan="2">Piping size</th> </tr> <tr> <th>Gas pipe</th> <th>Liquid pipe</th> </tr> </thead> <tbody> <tr> <td>&lt; 72</td> <td>φ5/8</td> <td>φ3/8</td> </tr> <tr> <td>72 ≤ x &lt; 111</td> <td>φ7/8</td> <td>φ3/8</td> </tr> <tr> <td>111 ≤ x &lt; 156</td> <td>φ1-1/8</td> <td>φ1/2</td> </tr> <tr> <td>156 ≤</td> <td>φ1-1/8</td> <td>φ5/8</td> </tr> </tbody> </table> |  | indoor capacity index      | Piping size                 |                 | Gas pipe                | Liquid pipe     | < 72                                | φ5/8            | φ3/8                    | 72 ≤ x < 111        | φ7/8            | φ3/8            | 111 ≤ x < 156  | φ1-1/8 | φ1/2 | 156 ≤ | φ1-1/8 | φ5/8 |  |  |  |  |  |      |  |  |  |  |  |  |  |  |  |  |
| indoor capacity index   | Piping size  |   |   |  |                            |                             |                 |                         |                 |                                     |                 |                         |                     |                 |                 |  |        |      |       |        |      |  |  |  |  |  |      |  |  |  |  |  |  |  |  |  |  |
|   | Gas pipe   | Liquid pipe   |   |  |                            |                             |                 |                         |                 |                                     |                 |                         |                     |                 |                 |  |        |      |       |        |      |  |  |  |  |  |      |  |  |  |  |  |  |  |  |  |  |
| < 72  | φ5/8   | φ3/8  |   |  |                            |                             |                 |                         |                 |                                     |                 |                         |                     |                 |                 |  |        |      |       |        |      |  |  |  |  |  |      |  |  |  |  |  |  |  |  |  |  |
| 72 ≤ x < 111  | φ7/8   | φ3/8  |   |  |                            |                             |                 |                         |                 |                                     |                 |                         |                     |                 |                 |  |        |      |       |        |      |  |  |  |  |  |      |  |  |  |  |  |  |  |  |  |  |
| 111 ≤ x < 156   | φ1-1/8   | φ1/2  |   |  |                            |                             |                 |                         |                 |                                     |                 |                         |                     |                 |                 |  |        |      |       |        |      |  |  |  |  |  |      |  |  |  |  |  |  |  |  |  |  |
| 156 ≤   | φ1-1/8   | φ5/8  |   |  |                            |                             |                 |                         |                 |                                     |                 |                         |                     |                 |                 |  |        |      |       |        |      |  |  |  |  |  |      |  |  |  |  |  |  |  |  |  |  |
|   |  | Piping between refrigerant branch kit and indoor unit<br>• Pipe size for direct connection to indoor unit must be the same as the connection size of indoor unit.   |   |  |                            |                             |                 |                         |                 |                                     |                 |                         |                     |                 |                 |  |        |      |       |        |      |  |  |  |  |  |      |  |  |  |  |  |  |  |  |  |  |
|   |  | (Unit: in.)   |   |  |                            |                             |                 |                         |                 |                                     |                 |                         |                     |                 |                 |  |        |      |       |        |      |  |  |  |  |  |      |  |  |  |  |  |  |  |  |  |  |
|   |  | <table border="1" style="width: 100%; border-collapse: collapse; font-size: x-small;"> <thead> <tr> <th rowspan="2">indoor capacity type</th> <th colspan="2">Piping size</th> </tr> <tr> <th>Gas pipe</th> <th>Liquid pipe</th> </tr> </thead> <tbody> <tr> <td>07, 09, 12, 18 type</td> <td>φ1/2</td> <td>φ1/4</td> </tr> <tr> <td>24, 30, 36, 48 type</td> <td>φ5/8</td> <td>φ3/8</td> </tr> </tbody> </table>   |   |  | indoor capacity type       | Piping size                 |                 | Gas pipe                | Liquid pipe     | 07, 09, 12, 18 type                 | φ1/2            | φ1/4                    | 24, 30, 36, 48 type | φ5/8            | φ3/8            |  |        |      |       |        |      |  |  |  |  |  |      |  |  |  |  |  |  |  |  |  |  |
| indoor capacity type  | Piping size  |   |   |  |                            |                             |                 |                         |                 |                                     |                 |                         |                     |                 |                 |  |        |      |       |        |      |  |  |  |  |  |      |  |  |  |  |  |  |  |  |  |  |
|   | Gas pipe   | Liquid pipe   |   |  |                            |                             |                 |                         |                 |                                     |                 |                         |                     |                 |                 |  |        |      |       |        |      |  |  |  |  |  |      |  |  |  |  |  |  |  |  |  |  |
| 07, 09, 12, 18 type   | φ1/2   | φ1/4  |   |  |                            |                             |                 |                         |                 |                                     |                 |                         |                     |                 |                 |  |        |      |       |        |      |  |  |  |  |  |      |  |  |  |  |  |  |  |  |  |  |
| 24, 30, 36, 48 type   | φ5/8   | φ3/8  |   |  |                            |                             |                 |                         |                 |                                     |                 |                         |                     |                 |                 |  |        |      |       |        |      |  |  |  |  |  |      |  |  |  |  |  |  |  |  |  |  |
|   |  | Piping between outdoor branch and outdoor unit (part B) (Unit: in.)   |   |  |                            |                             |                 |                         |                 |                                     |                 |                         |                     |                 |                 |  |        |      |       |        |      |  |  |  |  |  |      |  |  |  |  |  |  |  |  |  |  |
|   |  | <table border="1" style="width: 100%; border-collapse: collapse; font-size: x-small;"> <thead> <tr> <th rowspan="2">outdoor capacity type</th> <th colspan="2">Piping size</th> </tr> <tr> <th>Gas pipe</th> <th>Liquid pipe</th> </tr> </thead> <tbody> <tr> <td>RXYQ72</td> <td>φ3/4</td> <td>φ3/8</td> </tr> <tr> <td>RXYQ96</td> <td>φ7/8</td> <td>φ3/8</td> </tr> </tbody> </table>  |   |  | outdoor capacity type      | Piping size                 |                 | Gas pipe                | Liquid pipe     | RXYQ72                              | φ3/4            | φ3/8                    | RXYQ96              | φ7/8            | φ3/8            |  |        |      |       |        |      |  |  |  |  |  |      |  |  |  |  |  |  |  |  |  |  |
| outdoor capacity type   | Piping size  |   |   |  |                            |                             |                 |                         |                 |                                     |                 |                         |                     |                 |                 |  |        |      |       |        |      |  |  |  |  |  |      |  |  |  |  |  |  |  |  |  |  |
|   | Gas pipe   | Liquid pipe   |   |  |                            |                             |                 |                         |                 |                                     |                 |                         |                     |                 |                 |  |        |      |       |        |      |  |  |  |  |  |      |  |  |  |  |  |  |  |  |  |  |
| RXYQ72  | φ3/4   | φ3/8  |   |  |                            |                             |                 |                         |                 |                                     |                 |                         |                     |                 |                 |  |        |      |       |        |      |  |  |  |  |  |      |  |  |  |  |  |  |  |  |  |  |
| RXYQ96  | φ7/8   | φ3/8  |   |  |                            |                             |                 |                         |                 |                                     |                 |                         |                     |                 |                 |  |        |      |       |        |      |  |  |  |  |  |      |  |  |  |  |  |  |  |  |  |  |
|   |  | Oil-equalizing line (Only for multiple outdoor units installed) (part C) (Unit: in.)  |   |  |                            |                             |                 |                         |                 |                                     |                 |                         |                     |                 |                 |  |        |      |       |        |      |  |  |  |  |  |      |  |  |  |  |  |  |  |  |  |  |
|   |  | <table border="1" style="width: 100%; border-collapse: collapse; font-size: x-small;"> <thead> <tr> <th colspan="2">Piping size</th> </tr> </thead> <tbody> <tr> <td colspan="2">φ1/4</td> </tr> </tbody> </table>  |   |  | Piping size                |                             | φ1/4            |                         |                 |                                     |                 |                         |                     |                 |                 |  |        |      |       |        |      |  |  |  |  |  |      |  |  |  |  |  |  |  |  |  |  |
| Piping size   |  |   |   |  |                            |                             |                 |                         |                 |                                     |                 |                         |                     |                 |                 |  |        |      |       |        |      |  |  |  |  |  |      |  |  |  |  |  |  |  |  |  |  |
| φ1/4  |  |   |   |  |                            |                             |                 |                         |                 |                                     |                 |                         |                     |                 |                 |  |        |      |       |        |      |  |  |  |  |  |      |  |  |  |  |  |  |  |  |  |  |
| How to calculate the additional refrigerant to be charged   |  | Example for refrigerant branch using REFNET joint and REFNET header for RXYQ192   |   |  |                            |                             |                 |                         |                 |                                     |                 |                         |                     |                 |                 |  |        |      |       |        |      |  |  |  |  |  |      |  |  |  |  |  |  |  |  |  |  |
| Additional refrigerant to be charged R (lb.)<br>R should be rounded off in units of 0.1 (lb.).  |  | If the outdoor unit is RXYQ192 units and the piping lengths are as at right   |   |  |                            |                             |                 |                         |                 |                                     |                 |                         |                     |                 |                 |  |        |      |       |        |      |  |  |  |  |  |      |  |  |  |  |  |  |  |  |  |  |
| NOTE:<br>If a negative result is gotten for R from the formula at right, no refrigerant needs to be added.  |  | <table border="1" style="width: 100%; border-collapse: collapse; font-size: x-small;"> <thead> <tr> <th>a: φ3/4 × 100ft.</th> <th>b: φ5/8 × 30ft.</th> <th>c: φ3/8 × 30ft.</th> <th>d: φ3/8 × 30ft.</th> <th>e: φ3/8 × 30ft.</th> <th>f: φ3/8 × 30ft.</th> <th>g: φ1/4 × 30ft.</th> <th>h: φ1/4 × 70ft.</th> <th>i: φ1/2 × 30ft.</th> <th>j: φ1/4 × 30ft.</th> <th>k: φ1/4 × 25ft.</th> </tr> </thead> <tbody> <tr> <td colspan="11"> <math display="block">R = \left[ \frac{100 \times 0.168}{a} + \frac{30 \times 0.014}{b} + \frac{30 \times 0.074}{c} + \frac{120 \times 0.036}{d+e+f} + \frac{155 \times 0.015}{g+h+j+k} \right] - 6.6 = 22.485</math> </td> </tr> <tr> <td colspan="11" style="text-align: center;">                     22.5                 </td> </tr> </tbody> </table> |   |  | a: φ3/4 × 100ft.           | b: φ5/8 × 30ft.             | c: φ3/8 × 30ft. | d: φ3/8 × 30ft.         | e: φ3/8 × 30ft. | f: φ3/8 × 30ft.                     | g: φ1/4 × 30ft. | h: φ1/4 × 70ft.         | i: φ1/2 × 30ft.     | j: φ1/4 × 30ft. | k: φ1/4 × 25ft. | $R = \left[ \frac{100 \times 0.168}{a} + \frac{30 \times 0.014}{b} + \frac{30 \times 0.074}{c} + \frac{120 \times 0.036}{d+e+f} + \frac{155 \times 0.015}{g+h+j+k} \right] - 6.6 = 22.485$ |        |      |       |        |      |  |  |  |  |  | 22.5 |  |  |  |  |  |  |  |  |  |  |
| a: φ3/4 × 100ft.  | b: φ5/8 × 30ft.  | c: φ3/8 × 30ft.   | d: φ3/8 × 30ft.   | e: φ3/8 × 30ft.  | f: φ3/8 × 30ft.            | g: φ1/4 × 30ft.             | h: φ1/4 × 70ft. | i: φ1/2 × 30ft.         | j: φ1/4 × 30ft. | k: φ1/4 × 25ft.                     |                 |                         |                     |                 |                 |  |        |      |       |        |      |  |  |  |  |  |      |  |  |  |  |  |  |  |  |  |  |
| $R = \left[ \frac{100 \times 0.168}{a} + \frac{30 \times 0.014}{b} + \frac{30 \times 0.074}{c} + \frac{120 \times 0.036}{d+e+f} + \frac{155 \times 0.015}{g+h+j+k} \right] - 6.6 = 22.485$  |  |   |   |  |                            |                             |                 |                         |                 |                                     |                 |                         |                     |                 |                 |  |        |      |       |        |      |  |  |  |  |  |      |  |  |  |  |  |  |  |  |  |  |
| 22.5  |  |   |   |  |                            |                             |                 |                         |                 |                                     |                 |                         |                     |                 |                 |  |        |      |       |        |      |  |  |  |  |  |      |  |  |  |  |  |  |  |  |  |  |
|   |  | <table border="1" style="width: 100%; border-collapse: collapse; font-size: x-small;"> <thead> <tr> <th>Model name</th> <th>Amount of refrigerant</th> </tr> </thead> <tbody> <tr> <td>RXYQ72/96</td> <td>0 lb.</td> </tr> <tr> <td>RXYQ144/168/192</td> <td>6.6 lb.</td> </tr> </tbody> </table>   |   |  | Model name                 | Amount of refrigerant       | RXYQ72/96       | 0 lb.                   | RXYQ144/168/192 | 6.6 lb.                             |                 |                         |                     |                 |                 |  |        |      |       |        |      |  |  |  |  |  |      |  |  |  |  |  |  |  |  |  |  |
| Model name  | Amount of refrigerant  |   |   |  |                            |                             |                 |                         |                 |                                     |                 |                         |                     |                 |                 |  |        |      |       |        |      |  |  |  |  |  |      |  |  |  |  |  |  |  |  |  |  |
| RXYQ72/96   | 0 lb.  |   |   |  |                            |                             |                 |                         |                 |                                     |                 |                         |                     |                 |                 |  |        |      |       |        |      |  |  |  |  |  |      |  |  |  |  |  |  |  |  |  |  |
| RXYQ144/168/192   | 6.6 lb.  |   |   |  |                            |                             |                 |                         |                 |                                     |                 |                         |                     |                 |                 |  |        |      |       |        |      |  |  |  |  |  |      |  |  |  |  |  |  |  |  |  |  |





# 6. Thermistor Resistance / Temperature Characteristics

Indoor unit    For air suction                      R1T  
                     For liquid pipe                              R2T  
                     For gas pipe                                      R3T

Outdoor unit   For outdoor air                              R1T  
                     For suction pipe                              R2T  
                     For heat exchanger deicer                  R4T  
                     For sub cooling heat exchanger            R5T  
                     For receiver outlet liquid pipe            R6T  
                     For oil equalizing piping                    R7T

Outdoor unit fin thermistor R1T

| T°F | T°C | kΩ   |
|-----|-----|------|
| 14  | -10 | —    |
| 18  | -8  | —    |
| 21  | -6  | 88.0 |
| 25  | -4  | 79.1 |
| 28  | -2  | 71.1 |
| 32  | 0   | 64.1 |
| 35  | 2   | 57.8 |
| 39  | 4   | 52.3 |
| 43  | 6   | 47.3 |
| 46  | 8   | 42.9 |
| 50  | 10  | 38.9 |
| 54  | 12  | 35.3 |
| 57  | 14  | 32.1 |
| 61  | 16  | 29.2 |
| 64  | 18  | 26.6 |
| 68  | 20  | 24.3 |
| 72  | 22  | 22.2 |
| 75  | 24  | 20.3 |
| 79  | 26  | 18.5 |
| 82  | 28  | 17.0 |
| 86  | 30  | 15.6 |
| 90  | 32  | 14.2 |
| 93  | 34  | 13.1 |
| 97  | 36  | 12.0 |
| 100 | 38  | 11.1 |
| 104 | 40  | 10.3 |
| 108 | 42  | 9.5  |
| 111 | 44  | 8.8  |
| 115 | 46  | 8.2  |
| 118 | 48  | 7.6  |
| 122 | 50  | 7.0  |
| 126 | 52  | 6.7  |
| 129 | 54  | 6.0  |
| 133 | 56  | 5.5  |
| 136 | 58  | 5.2  |
| 140 | 60  | 4.79 |
| 144 | 62  | 4.46 |
| 147 | 64  | 4.15 |
| 151 | 66  | 3.87 |
| 154 | 68  | 3.61 |
| 158 | 70  | 3.37 |
| 162 | 72  | 3.15 |
| 165 | 74  | 2.94 |
| 169 | 76  | 2.75 |
| 172 | 78  | 2.51 |
| 176 | 80  | 2.41 |
| 180 | 82  | 2.26 |
| 183 | 84  | 2.12 |
| 187 | 86  | 1.99 |
| 190 | 88  | 1.87 |
| 194 | 90  | 1.76 |
| 198 | 92  | 1.65 |
| 201 | 94  | 1.55 |
| 205 | 96  | 1.46 |
| 208 | 98  | 1.38 |

| T°F  | T°C | kΩ     |
|------|-----|--------|
| -4.0 | -20 | 197.81 |
| -2.2 | -19 | 186.53 |
| -0.4 | -18 | 175.97 |
| 1.4  | -17 | 166.07 |
| 3.2  | -16 | 156.80 |
| 5.0  | -15 | 148.10 |
| 6.8  | -14 | 139.94 |
| 8.6  | -13 | 132.28 |
| 10.4 | -12 | 125.09 |
| 12.2 | -11 | 118.34 |
| 14.0 | -10 | 111.99 |
| 15.8 | -9  | 106.03 |
| 17.6 | -8  | 100.41 |
| 19.4 | -7  | 95.14  |
| 21.2 | -6  | 90.17  |
| 23.0 | -5  | 85.49  |
| 24.8 | -4  | 81.08  |
| 26.6 | -3  | 76.93  |
| 28.4 | -2  | 73.01  |
| 30.2 | -1  | 69.32  |
| 32.0 | 0   | 65.84  |
| 33.8 | 1   | 62.54  |
| 35.6 | 2   | 59.43  |
| 37.4 | 3   | 56.49  |
| 39.2 | 4   | 53.71  |
| 41.0 | 5   | 51.09  |
| 42.8 | 6   | 48.61  |
| 44.6 | 7   | 46.26  |
| 46.4 | 8   | 44.05  |
| 48.2 | 9   | 41.95  |
| 50.0 | 10  | 39.96  |
| 51.8 | 11  | 38.08  |
| 53.6 | 12  | 36.30  |
| 55.4 | 13  | 34.62  |
| 57.2 | 14  | 33.02  |
| 59.0 | 15  | 31.50  |
| 60.8 | 16  | 30.06  |
| 62.6 | 17  | 28.70  |
| 64.4 | 18  | 27.41  |
| 66.2 | 19  | 26.18  |
| 68.0 | 20  | 25.01  |
| 69.8 | 21  | 23.91  |
| 71.6 | 22  | 22.85  |
| 73.4 | 23  | 21.85  |
| 75.2 | 24  | 20.90  |
| 77.0 | 25  | 20.00  |
| 78.8 | 26  | 19.14  |
| 80.6 | 27  | 18.32  |
| 82.4 | 28  | 17.54  |
| 84.2 | 29  | 16.80  |
| 86.0 | 30  | 16.10  |

| T°F   | T°C | kΩ    |
|-------|-----|-------|
| 86.0  | 30  | 16.10 |
| 87.8  | 31  | 15.43 |
| 89.6  | 32  | 14.79 |
| 91.4  | 33  | 14.18 |
| 93.2  | 34  | 13.59 |
| 95.0  | 35  | 13.04 |
| 96.8  | 36  | 12.51 |
| 98.6  | 37  | 12.01 |
| 100.4 | 38  | 11.52 |
| 102.2 | 39  | 11.06 |
| 104.0 | 40  | 10.63 |
| 105.8 | 41  | 10.21 |
| 107.6 | 42  | 9.81  |
| 109.4 | 43  | 9.42  |
| 111.2 | 44  | 9.06  |
| 113.0 | 45  | 8.71  |
| 114.8 | 46  | 8.37  |
| 116.6 | 47  | 8.05  |
| 118.4 | 48  | 7.75  |
| 120.2 | 49  | 7.46  |
| 122.0 | 50  | 7.18  |
| 123.8 | 51  | 6.91  |
| 125.6 | 52  | 6.65  |
| 127.4 | 53  | 6.41  |
| 129.2 | 54  | 6.65  |
| 131.0 | 55  | 6.41  |
| 132.8 | 56  | 6.18  |
| 134.6 | 57  | 5.95  |
| 136.4 | 58  | 5.74  |
| 138.2 | 59  | 5.14  |
| 140.0 | 60  | 4.96  |
| 141.8 | 61  | 4.79  |
| 143.6 | 62  | 4.62  |
| 145.4 | 63  | 4.46  |
| 147.2 | 64  | 4.30  |
| 149.0 | 65  | 4.16  |
| 150.8 | 66  | 4.01  |
| 152.6 | 67  | 3.88  |
| 154.4 | 68  | 3.75  |
| 156.2 | 69  | 3.62  |
| 158.0 | 70  | 3.50  |
| 159.8 | 71  | 3.38  |
| 161.6 | 72  | 3.27  |
| 163.4 | 73  | 3.16  |
| 165.2 | 74  | 3.06  |
| 167.0 | 75  | 2.96  |
| 168.8 | 76  | 2.86  |
| 170.6 | 77  | 2.77  |
| 172.4 | 78  | 2.68  |
| 174.2 | 79  | 2.60  |
| 176.0 | 80  | 2.51  |

**Outdoor Unit  
Thermistors for  
Discharge Pipe  
(R3T, R31T, R32T)**

| T°F   | T°C | kΩ     |
|-------|-----|--------|
| 32.0  | 0   | 640.44 |
| 33.8  | 1   | 609.31 |
| 35.6  | 2   | 579.96 |
| 37.4  | 3   | 552.00 |
| 39.2  | 4   | 525.63 |
| 41.0  | 5   | 500.66 |
| 42.8  | 6   | 477.01 |
| 44.6  | 7   | 454.60 |
| 46.4  | 8   | 433.37 |
| 48.2  | 9   | 413.24 |
| 50.0  | 10  | 394.16 |
| 51.8  | 11  | 376.05 |
| 53.6  | 12  | 358.88 |
| 55.4  | 13  | 342.58 |
| 57.2  | 14  | 327.10 |
| 59.0  | 15  | 312.41 |
| 60.8  | 16  | 298.45 |
| 62.6  | 17  | 285.18 |
| 64.4  | 18  | 272.58 |
| 66.2  | 19  | 260.60 |
| 68.0  | 20  | 249.00 |
| 69.8  | 21  | 238.36 |
| 71.6  | 22  | 228.05 |
| 73.4  | 23  | 218.24 |
| 75.2  | 24  | 208.90 |
| 77.0  | 25  | 200.00 |
| 78.8  | 26  | 191.53 |
| 80.6  | 27  | 183.46 |
| 82.4  | 28  | 175.77 |
| 84.2  | 29  | 168.44 |
| 86.0  | 30  | 161.45 |
| 86.0  | 31  | 154.79 |
| 87.8  | 32  | 148.43 |
| 89.6  | 33  | 142.37 |
| 91.4  | 34  | 136.59 |
| 93.2  | 35  | 131.06 |
| 95.0  | 36  | 125.79 |
| 96.8  | 37  | 120.76 |
| 98.6  | 38  | 115.95 |
| 100.4 | 39  | 111.35 |
| 102.2 | 40  | 106.96 |
| 104.0 | 41  | 102.76 |
| 105.8 | 42  | 98.75  |
| 107.6 | 43  | 94.92  |
| 109.4 | 44  | 91.25  |
| 111.2 | 45  | 87.74  |
| 113.0 | 46  | 84.38  |
| 114.8 | 47  | 81.16  |
| 116.6 | 48  | 78.09  |
| 118.4 | 49  | 75.14  |
| 120.2 | 50  | 72.32  |

| T°F   | T°C | kΩ    |
|-------|-----|-------|
| 122.0 | 50  | 72.32 |
| 123.8 | 51  | 69.64 |
| 125.6 | 52  | 67.06 |
| 127.4 | 53  | 64.60 |
| 129.2 | 54  | 62.24 |
| 131.0 | 55  | 59.97 |
| 132.8 | 56  | 57.80 |
| 134.6 | 57  | 55.72 |
| 136.4 | 58  | 53.72 |
| 138.2 | 59  | 51.98 |
| 140.0 | 60  | 49.96 |
| 141.8 | 61  | 48.19 |
| 143.6 | 62  | 46.49 |
| 145.4 | 63  | 44.86 |
| 147.2 | 64  | 43.30 |
| 149.0 | 65  | 41.79 |
| 150.8 | 66  | 40.35 |
| 152.6 | 67  | 38.96 |
| 154.4 | 68  | 37.63 |
| 156.2 | 69  | 36.34 |
| 158.0 | 70  | 35.11 |
| 159.8 | 71  | 33.92 |
| 161.6 | 72  | 32.78 |
| 163.4 | 73  | 31.69 |
| 165.2 | 74  | 30.63 |
| 167.0 | 75  | 29.61 |
| 168.8 | 76  | 28.64 |
| 170.6 | 77  | 27.69 |
| 172.4 | 78  | 26.79 |
| 174.2 | 79  | 25.91 |
| 176.0 | 80  | 25.07 |
| 177.8 | 81  | 24.26 |
| 179.6 | 82  | 23.48 |
| 181.4 | 83  | 22.73 |
| 183.2 | 84  | 22.01 |
| 185.0 | 85  | 21.31 |
| 186.8 | 86  | 20.63 |
| 188.6 | 87  | 19.98 |
| 190.4 | 88  | 19.36 |
| 192.2 | 89  | 18.75 |
| 194.0 | 90  | 18.17 |
| 195.8 | 91  | 17.61 |
| 197.6 | 92  | 17.07 |
| 199.4 | 93  | 16.54 |
| 201.2 | 94  | 16.04 |
| 203.0 | 95  | 15.55 |
| 204.8 | 96  | 15.08 |
| 206.6 | 97  | 14.62 |
| 208.4 | 98  | 14.18 |
| 210.2 | 99  | 13.76 |
| 212.0 | 100 | 13.35 |

| T°F   | T°C | kΩ    |
|-------|-----|-------|
| 212.0 | 100 | 13.35 |
| 213.8 | 101 | 12.95 |
| 215.6 | 102 | 12.57 |
| 217.4 | 103 | 12.20 |
| 219.2 | 104 | 11.84 |
| 221.0 | 105 | 11.49 |
| 222.8 | 106 | 11.15 |
| 224.6 | 107 | 10.83 |
| 226.4 | 108 | 10.52 |
| 228.2 | 109 | 10.21 |
| 230.0 | 110 | 9.92  |
| 231.8 | 111 | 9.64  |
| 233.6 | 112 | 9.36  |
| 235.4 | 113 | 9.10  |
| 237.2 | 114 | 8.84  |
| 239.0 | 115 | 8.59  |
| 240.8 | 116 | 8.35  |
| 242.6 | 117 | 8.12  |
| 244.4 | 118 | 7.89  |
| 246.2 | 119 | 7.68  |
| 248.0 | 120 | 7.47  |
| 249.8 | 121 | 7.26  |
| 251.6 | 122 | 7.06  |
| 253.4 | 123 | 6.87  |
| 255.2 | 124 | 6.69  |
| 257.0 | 125 | 6.51  |
| 258.8 | 126 | 6.33  |
| 260.6 | 127 | 6.16  |
| 262.4 | 128 | 6.00  |
| 264.2 | 129 | 5.84  |
| 266.0 | 130 | 5.69  |
| 267.8 | 131 | 5.54  |
| 269.6 | 132 | 5.39  |
| 271.4 | 133 | 5.25  |
| 273.2 | 134 | 5.12  |
| 275.0 | 135 | 4.98  |
| 276.8 | 136 | 4.86  |
| 278.6 | 137 | 4.73  |
| 280.4 | 138 | 4.61  |
| 282.2 | 139 | 4.49  |
| 284.0 | 140 | 4.38  |
| 285.8 | 141 | 4.27  |
| 287.6 | 142 | 4.16  |
| 289.4 | 143 | 4.06  |
| 291.2 | 144 | 3.96  |
| 293.0 | 145 | 3.86  |
| 294.8 | 146 | 3.76  |
| 296.6 | 147 | 3.67  |
| 298.4 | 148 | 3.58  |
| 300.2 | 149 | 3.49  |
| 302.0 | 150 | 3.41  |

# 7. Pressure Sensor

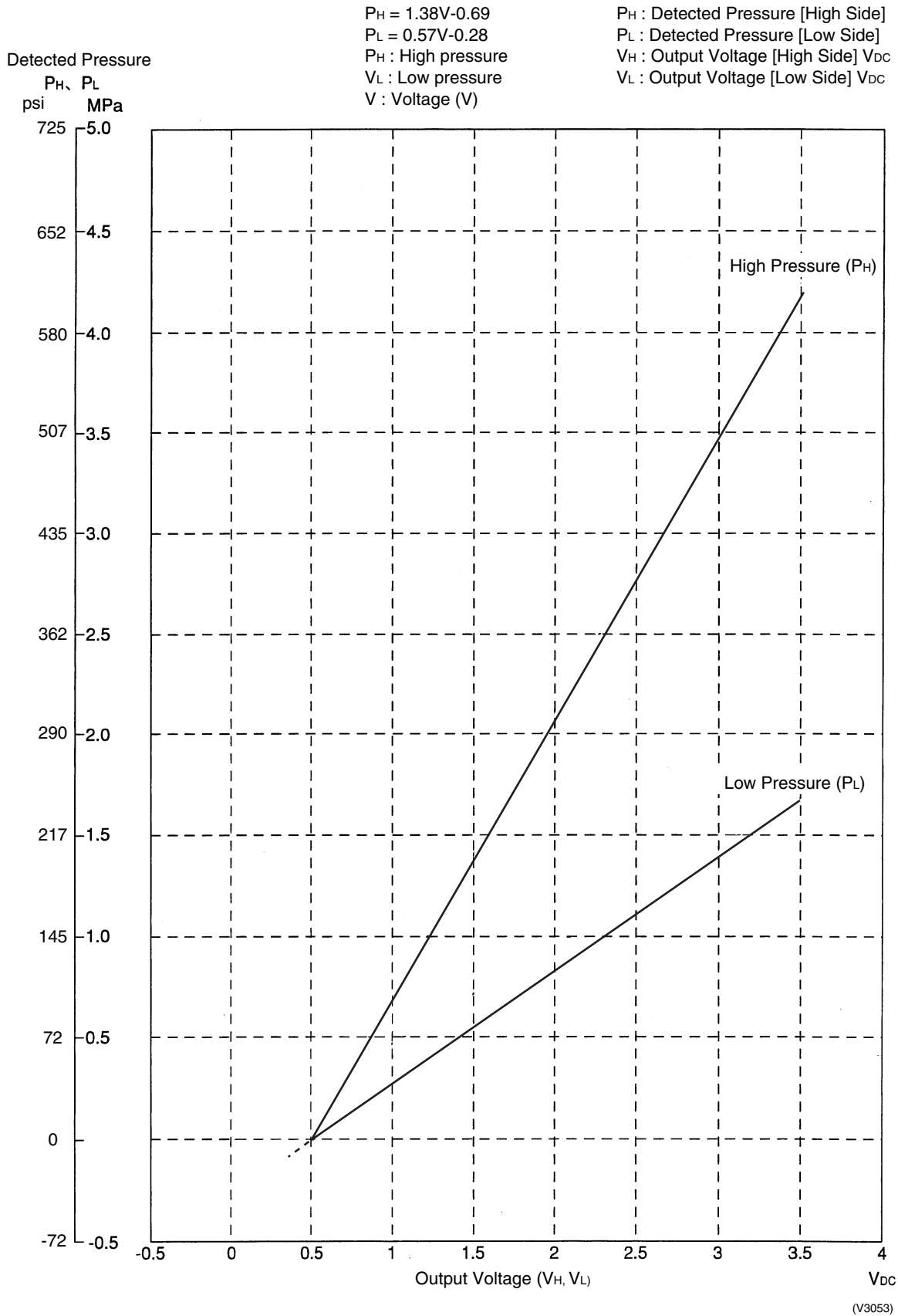

# 8. Method of Replacing The Inverter's Power Transistors and Diode Modules

## 8.1 Method of Replacing The Inverter's Power Transistors and Diode Modules

Inverter P.C.Board

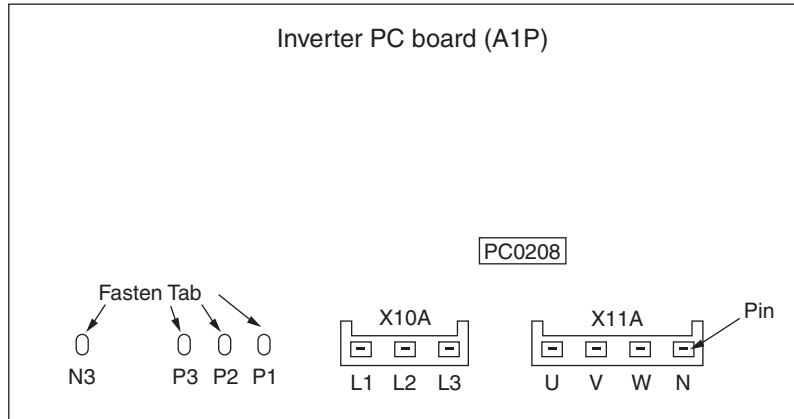

Electronic circuit

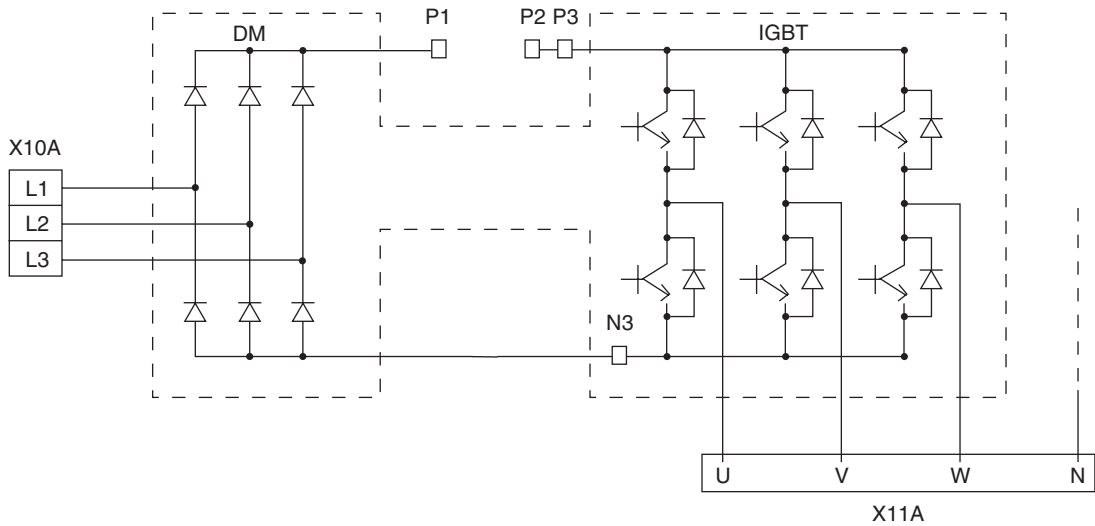

(V2895)

[Decision according to continuity check by analog tester]

- Before checking, disconnect the electric wiring connected to the power transistor and diode module.

**Power Transistor IGBT (On Inverter PC Board)**

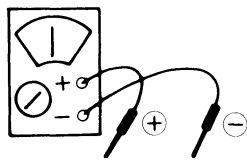

|    |   |    |                |     |
|----|---|----|----------------|-----|
| P3 | - | U  | Continuity     | } ✘ |
| ∕  | - | V  | ∕              |     |
| ∕  | - | W  | ∕              |     |
| ∕  | - | N  | (Approx.100kΩ) |     |
| U  | - | P3 | Approx.4kΩ → ∞ |     |
| V  | - | ∕  | ∕              |     |
| W  | - | ∕  | ∕              |     |
| N  | - | ∕  | (Approx.160kΩ) |     |

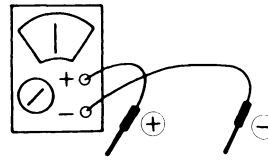

|    |   |    |                |   |
|----|---|----|----------------|---|
| N3 | - | U  | Approx.4kΩ → ∞ |   |
| ∕  | - | V  | ∕              |   |
| ∕  | - | W  | ∕              |   |
| ∕  | - | N  | (Approx.250kΩ) |   |
| U  | - | N3 | Continuity     | } ✘ *In the case of continuity, the resistance must be the same for all phases. |
| V  | - | ∕  | ∕              |   |
| W  | - | ∕  | ∕              |   |
| N  | - | ∕  | (Approx.100kΩ) |   |

(V2896)

**(Decision)**

If other than given above, the power unit is defective and must be replaced.



**Note:** If using a digital tester, ∞ and continuity may be reversed.

**Diode Module**

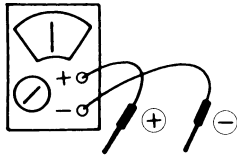

|    |   |    |            |
|----|---|----|------------|
| P1 | - | L1 | Continuity |
| P1 | - | L2 | ∕          |
| P1 | - | L3 | ∕          |
| L1 | - | P1 | ∞          |
| L2 | - | P1 | ∞          |
| L3 | - | P1 | ∞          |

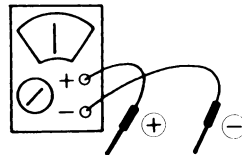

|    |   |    |            |
|----|---|----|------------|
| N3 | - | L1 | ∞          |
| ∕  | - | L2 | ∞          |
| ∕  | - | L3 | ∞          |
| L1 | - | N3 | Continuity |
| L2 | - | ∕  | ∕          |
| L3 | - | ∕  | ∕          |

(V2897)

**(Decision)**

If other than given above, the diode module is defective and must be replaced.



**Note:** If using a digital tester, ∞ and continuity may be reversed.



# Part 9 Precautions for New Refrigerant (R-410A)

|   |     |
|---|-----|
| 1. Precautions for New Refrigerant (R-410A) ..... | 246 |
| 1.1 Outline .....                                 | 246 |
| 1.2 Service Tools.....                            | 248 |



# 1. Precautions for New Refrigerant (R-410A)

## 1.1 Outline

### 1.1.1 About Refrigerant R-410A

- Characteristics of new refrigerant, R-410A
  1. Performance  
Almost the same performance as R-22 and R-407C
  2. Pressure  
Working pressure is approx. 1.4 times more than R-22 and R-407C.
  3. Refrigerant composition  
Few problems in composition control, since it is a Quasi-azeotropic mixture refrigerant.

| Refrigerant name               | HFC units (Units using new refrigerants)                            |   | HCFC units  |
|--------------------------------|---|---|---|
|                                | R-407C  | R-410A  | R-22  |
| Composing substances           | Non-azeotropic mixture of HFC32, HFC125 and HFC134a (*1)            | Quasi-azeotropic mixture of HFC32 and JFC125 (*1)                   | Single-component refrigerant  |
| Design pressure                | 3.2 MPa (gauge pressure)<br>= 32.6 kgf/cm <sup>2</sup><br>= 464 psi | 4.0 MPa (gauge pressure)<br>= 40.8 kgf/cm <sup>2</sup><br>= 580 psi | 2.75MPa (gauge pressure)<br>= 28.0 kgf/cm <sup>2</sup><br>= 399 psi |
| Refrigerant oil                | Synthetic oil (Ether)   |   | Mineral oil (Suniso)  |
| Ozone destruction factor (ODP) | 0   | 0   | 0.05  |
| Combustibility                 | None  | None  | None  |
| Toxicity                       | None  | None  | None  |

- ★1. Non-azeotropic mixture refrigerant: mixture of two or more refrigerants having different boiling points.
- ★2. Quasi-azeotropic mixture refrigerant: mixture of two or more refrigerants having similar boiling points.
- ★3. The design pressure is different at each product. Please refer to the installation manual for each product.

(Reference) 1 MPa ≙ 10.19716 kgf / cm<sup>2</sup>  
1 MPa ≙ 145 psi

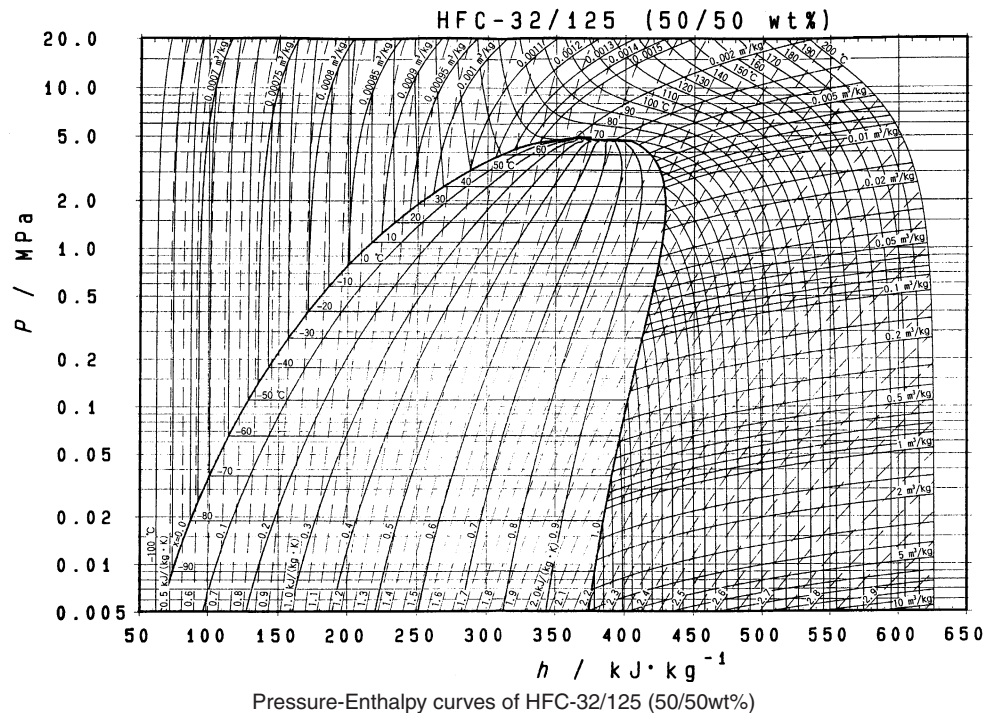

■ Thermodynamic characteristic of R-410A

DAIREP ver2.0

| Temperature<br>(°C) | Steam pressure<br>(kPa) |        | Density<br>(kg/m <sup>3</sup> ) |       | Specific heat at constant<br>pressure (kJ/kgK) |       | Specific enthalpy<br>(kJ/kg) |       | Specific entropy<br>(kJ/KgK) |       |
|---------------------|-------------------------|--------|---------------------------------|-------|--|-------|------------------------------|-------|------------------------------|-------|
|                     | Liquid                  | Vapor  | Liquid                          | Vapor | Liquid   | Vapor | Liquid                       | Vapor | Liquid                       | Vapor |
| -70                 | 36.13                   | 36.11  | 1410.7                          | 1.582 | 1.372  | 0.695 | 100.8                        | 390.6 | 0.649                        | 2.074 |
| -68                 | 40.83                   | 40.80  | 1404.7                          | 1.774 | 1.374  | 0.700 | 103.6                        | 391.8 | 0.663                        | 2.066 |
| -66                 | 46.02                   | 45.98  | 1398.6                          | 1.984 | 1.375  | 0.705 | 106.3                        | 393.0 | 0.676                        | 2.058 |
| -64                 | 51.73                   | 51.68  | 1392.5                          | 2.213 | 1.377  | 0.710 | 109.1                        | 394.1 | 0.689                        | 2.051 |
| -62                 | 58.00                   | 57.94  | 1386.4                          | 2.463 | 1.378  | 0.715 | 111.9                        | 395.3 | 0.702                        | 2.044 |
| -60                 | 64.87                   | 64.80  | 1380.2                          | 2.734 | 1.379  | 0.720 | 114.6                        | 396.4 | 0.715                        | 2.037 |
| -58                 | 72.38                   | 72.29  | 1374.0                          | 3.030 | 1.380  | 0.726 | 117.4                        | 397.6 | 0.728                        | 2.030 |
| -56                 | 80.57                   | 80.46  | 1367.8                          | 3.350 | 1.382  | 0.732 | 120.1                        | 398.7 | 0.741                        | 2.023 |
| -54                 | 89.49                   | 89.36  | 1361.6                          | 3.696 | 1.384  | 0.737 | 122.9                        | 399.8 | 0.754                        | 2.017 |
| -52                 | 99.18                   | 99.03  | 1355.3                          | 4.071 | 1.386  | 0.744 | 125.7                        | 400.9 | 0.766                        | 2.010 |
| -51.58              | 101.32                  | 101.17 | 1354.0                          | 4.153 | 1.386  | 0.745 | 126.3                        | 401.1 | 0.769                        | 2.009 |
| -50                 | 109.69                  | 109.51 | 1349.0                          | 4.474 | 1.388  | 0.750 | 128.5                        | 402.0 | 0.779                        | 2.004 |
| -48                 | 121.07                  | 120.85 | 1342.7                          | 4.909 | 1.391  | 0.756 | 131.2                        | 403.1 | 0.791                        | 1.998 |
| -46                 | 133.36                  | 133.11 | 1336.3                          | 5.377 | 1.394  | 0.763 | 134.0                        | 404.1 | 0.803                        | 1.992 |
| -44                 | 146.61                  | 146.32 | 1330.0                          | 5.880 | 1.397  | 0.770 | 136.8                        | 405.2 | 0.816                        | 1.987 |
| -42                 | 160.89                  | 160.55 | 1323.5                          | 6.419 | 1.401  | 0.777 | 139.6                        | 406.2 | 0.828                        | 1.981 |
| -40                 | 176.24                  | 175.85 | 1317.0                          | 6.996 | 1.405  | 0.785 | 142.4                        | 407.3 | 0.840                        | 1.976 |
| -38                 | 192.71                  | 192.27 | 1310.5                          | 7.614 | 1.409  | 0.792 | 145.3                        | 408.3 | 0.852                        | 1.970 |
| -36                 | 210.37                  | 209.86 | 1304.0                          | 8.275 | 1.414  | 0.800 | 148.1                        | 409.3 | 0.864                        | 1.965 |
| -34                 | 229.26                  | 228.69 | 1297.3                          | 8.980 | 1.419  | 0.809 | 150.9                        | 410.2 | 0.875                        | 1.960 |
| -32                 | 249.46                  | 248.81 | 1290.6                          | 9.732 | 1.424  | 0.817 | 153.8                        | 411.2 | 0.887                        | 1.955 |
| -30                 | 271.01                  | 270.28 | 1283.9                          | 10.53 | 1.430  | 0.826 | 156.6                        | 412.1 | 0.899                        | 1.950 |
| -28                 | 293.99                  | 293.16 | 1277.1                          | 11.39 | 1.436  | 0.835 | 159.5                        | 413.1 | 0.911                        | 1.946 |
| -26                 | 318.44                  | 317.52 | 1270.2                          | 12.29 | 1.442  | 0.844 | 162.4                        | 414.0 | 0.922                        | 1.941 |
| -24                 | 344.44                  | 343.41 | 1263.3                          | 13.26 | 1.448  | 0.854 | 165.3                        | 414.9 | 0.934                        | 1.936 |
| -22                 | 372.05                  | 370.90 | 1256.3                          | 14.28 | 1.455  | 0.864 | 168.2                        | 415.7 | 0.945                        | 1.932 |
| -20                 | 401.34                  | 400.06 | 1249.2                          | 15.37 | 1.461  | 0.875 | 171.1                        | 416.6 | 0.957                        | 1.927 |
| -18                 | 432.36                  | 430.95 | 1242.0                          | 16.52 | 1.468  | 0.886 | 174.1                        | 417.4 | 0.968                        | 1.923 |
| -16                 | 465.20                  | 463.64 | 1234.8                          | 17.74 | 1.476  | 0.897 | 177.0                        | 418.2 | 0.980                        | 1.919 |
| -14                 | 499.91                  | 498.20 | 1227.5                          | 19.04 | 1.483  | 0.909 | 180.0                        | 419.0 | 0.991                        | 1.914 |
| -12                 | 536.58                  | 534.69 | 1220.0                          | 20.41 | 1.491  | 0.921 | 182.9                        | 419.8 | 1.003                        | 1.910 |
| -10                 | 575.26                  | 573.20 | 1212.5                          | 21.86 | 1.499  | 0.933 | 185.9                        | 420.5 | 1.014                        | 1.906 |
| -8                  | 616.03                  | 613.78 | 1204.9                          | 23.39 | 1.507  | 0.947 | 189.0                        | 421.2 | 1.025                        | 1.902 |
| -6                  | 658.97                  | 656.52 | 1197.2                          | 25.01 | 1.516  | 0.960 | 192.0                        | 421.9 | 1.036                        | 1.898 |
| -4                  | 704.15                  | 701.49 | 1189.4                          | 26.72 | 1.524  | 0.975 | 195.0                        | 422.6 | 1.048                        | 1.894 |
| -2                  | 751.64                  | 748.76 | 1181.4                          | 28.53 | 1.533  | 0.990 | 198.1                        | 423.2 | 1.059                        | 1.890 |
| 0                   | 801.52                  | 798.41 | 1173.4                          | 30.44 | 1.543  | 1.005 | 201.2                        | 423.8 | 1.070                        | 1.886 |
| 2                   | 853.87                  | 850.52 | 1165.3                          | 32.46 | 1.552  | 1.022 | 204.3                        | 424.4 | 1.081                        | 1.882 |
| 4                   | 908.77                  | 905.16 | 1157.0                          | 34.59 | 1.563  | 1.039 | 207.4                        | 424.9 | 1.092                        | 1.878 |
| 6                   | 966.29                  | 962.42 | 1148.6                          | 36.83 | 1.573  | 1.057 | 210.5                        | 425.5 | 1.103                        | 1.874 |
| 8                   | 1026.5                  | 1022.4 | 1140.0                          | 39.21 | 1.584  | 1.076 | 213.7                        | 425.9 | 1.114                        | 1.870 |
| 10                  | 1089.5                  | 1085.1 | 1131.3                          | 41.71 | 1.596  | 1.096 | 216.8                        | 426.4 | 1.125                        | 1.866 |
| 12                  | 1155.4                  | 1150.7 | 1122.5                          | 44.35 | 1.608  | 1.117 | 220.0                        | 426.8 | 1.136                        | 1.862 |
| 14                  | 1224.3                  | 1219.2 | 1113.5                          | 47.14 | 1.621  | 1.139 | 223.2                        | 427.2 | 1.147                        | 1.859 |
| 16                  | 1296.2                  | 1290.8 | 1104.4                          | 50.09 | 1.635  | 1.163 | 226.5                        | 427.5 | 1.158                        | 1.855 |
| 18                  | 1371.2                  | 1365.5 | 1095.1                          | 53.20 | 1.650  | 1.188 | 229.7                        | 427.8 | 1.169                        | 1.851 |
| 20                  | 1449.4                  | 1443.4 | 1085.6                          | 56.48 | 1.666  | 1.215 | 233.0                        | 428.1 | 1.180                        | 1.847 |
| 22                  | 1530.9                  | 1524.6 | 1075.9                          | 59.96 | 1.683  | 1.243 | 236.4                        | 428.3 | 1.191                        | 1.843 |
| 24                  | 1615.8                  | 1609.2 | 1066.0                          | 63.63 | 1.701  | 1.273 | 239.7                        | 428.4 | 1.202                        | 1.839 |
| 26                  | 1704.2                  | 1697.2 | 1055.9                          | 67.51 | 1.721  | 1.306 | 243.1                        | 428.6 | 1.214                        | 1.834 |
| 28                  | 1796.2                  | 1788.9 | 1045.5                          | 71.62 | 1.743  | 1.341 | 246.5                        | 428.6 | 1.225                        | 1.830 |
| 30                  | 1891.9                  | 1884.2 | 1034.9                          | 75.97 | 1.767  | 1.379 | 249.9                        | 428.6 | 1.236                        | 1.826 |
| 32                  | 1991.3                  | 1983.2 | 1024.1                          | 80.58 | 1.793  | 1.420 | 253.4                        | 428.6 | 1.247                        | 1.822 |
| 34                  | 2094.5                  | 2086.2 | 1012.9                          | 85.48 | 1.822  | 1.465 | 256.9                        | 428.4 | 1.258                        | 1.817 |
| 36                  | 2201.7                  | 2193.1 | 1001.4                          | 90.68 | 1.855  | 1.514 | 260.5                        | 428.3 | 1.269                        | 1.813 |
| 38                  | 2313.0                  | 2304.0 | 989.5                           | 96.22 | 1.891  | 1.569 | 264.1                        | 428.0 | 1.281                        | 1.808 |
| 40                  | 2428.4                  | 2419.2 | 977.3                           | 102.1 | 1.932  | 1.629 | 267.8                        | 427.7 | 1.292                        | 1.803 |
| 42                  | 2548.1                  | 2538.6 | 964.6                           | 108.4 | 1.979  | 1.696 | 271.5                        | 427.2 | 1.303                        | 1.798 |
| 44                  | 2672.2                  | 2662.4 | 951.4                           | 115.2 | 2.033  | 1.771 | 275.3                        | 426.7 | 1.315                        | 1.793 |
| 46                  | 2800.7                  | 2790.7 | 937.7                           | 122.4 | 2.095  | 1.857 | 279.2                        | 426.1 | 1.327                        | 1.788 |
| 48                  | 2933.7                  | 2923.6 | 923.3                           | 130.2 | 2.168  | 1.955 | 283.2                        | 425.4 | 1.339                        | 1.782 |
| 50                  | 3071.5                  | 3061.2 | 908.2                           | 138.6 | 2.256  | 2.069 | 287.3                        | 424.5 | 1.351                        | 1.776 |
| 52                  | 3214.0                  | 3203.6 | 892.2                           | 147.7 | 2.362  | 2.203 | 291.5                        | 423.5 | 1.363                        | 1.770 |
| 54                  | 3361.4                  | 3351.0 | 875.1                           | 157.6 | 2.493  | 2.363 | 295.8                        | 422.4 | 1.376                        | 1.764 |
| 56                  | 3513.8                  | 3503.5 | 856.8                           | 168.4 | 2.661  | 2.557 | 300.3                        | 421.0 | 1.389                        | 1.757 |
| 58                  | 3671.3                  | 3661.2 | 836.9                           | 180.4 | 2.883  | 2.799 | 305.0                        | 419.4 | 1.403                        | 1.749 |
| 60                  | 3834.1                  | 3824.2 | 814.9                           | 193.7 | 3.191  | 3.106 | 310.0                        | 417.6 | 1.417                        | 1.741 |
| 62                  | 4002.1                  | 3992.7 | 790.1                           | 208.6 | 3.650  | 3.511 | 315.3                        | 415.5 | 1.433                        | 1.732 |
| 64                  | 4175.7                  | 4166.8 | 761.0                           | 225.6 | 4.415  | 4.064 | 321.2                        | 413.0 | 1.450                        | 1.722 |

## 1.2 Service Tools

R-410A is used under higher working pressure, compared to previous refrigerants (R-22,R-407C). Furthermore, the refrigerating machine oil has been changed from Suniso oil to Ether oil, and if oil mixing is occurred, sludge results in the refrigerants and causes other problems. Therefore, gauge manifolds and charge hoses that are used with a previous refrigerant (R-22,R-407C) can not be used for products that use new refrigerants.

Be sure to use dedicated tools and devices.

### ■ Tool compatibility

| Tool  | Compatibility               |        |      | Reasons for change  |
|---|-----------------------------|--------|------|---|
|   | HFC                         |        | HCFC |   |
|   | R-410A                      | R-407C | R-22 |   |
| Gauge manifold<br>Charge hose                               | ×                           |        |      | <ul style="list-style-type: none"> <li>Do not use the same tools for R-22 and R-410A.</li> <li>Thread specification differs for R-410A and R-407C.</li> </ul> |
| Gas detector  | ○                           |        | ×    | <ul style="list-style-type: none"> <li>The same tool can be used for HFCs.</li> </ul>   |
| Vacuum pump<br>(pump with reverse flow preventive function) |                             | ○      |      | <ul style="list-style-type: none"> <li>To use existing pump for HFCs, vacuum pump adaptor must be installed.</li> </ul>                                       |
| Weighting instrument  |                             | ○      |      |   |
| Flaring tool (Clutch type)                                  |                             | ○      |      | <ul style="list-style-type: none"> <li>For R-410A, flare gauge is necessary.</li> </ul>   |
| Torque wrench   |                             | ○      |      | <ul style="list-style-type: none"> <li>Torque-up for 1/2 and 5/8</li> </ul>   |
| Pipe cutter   |                             | ○      |      |   |
| Pipe expander   |                             | ○      |      |   |
| Pipe bender   |                             | ○      |      |   |
| Pipe assembling oil   |                             | ×      |      | <ul style="list-style-type: none"> <li>Due to refrigerating machine oil change. (No Suniso oil can be used.)</li> </ul>                                       |
| Refrigerant recovery device                                 | Check your recovery device. |        |      |   |
| Refrigerant piping  | See the chart below.        |        |      | <ul style="list-style-type: none"> <li>Only φ19.1 is changed to 1/2H material while the previous material is "O".</li> </ul>                                  |

As for the charge mouthpiece and packing, 1/2UNF20 is necessary for mouthpiece size of charge hose.

### ■ Copper tube material and thickness

| Pipe size | R-407C   |                | R-410A   |                |
|-----------|----------|----------------|----------|----------------|
|           | Material | Thickness [mm] | Material | Thickness [mm] |
| φ6.4      | O        | 0.8            | O        | 0.8            |
| φ9.5      | O        | 0.8            | O        | 0.8            |
| φ12.7     | O        | 0.8            | O        | 0.8            |
| φ15.9     | O        | 1.0            | O        | 1.0            |
| φ19.1     | O        | 1.0            | 1/2H     | 1.0            |
| φ22.2     | 1/2H     | 1.0            | 1/2H     | 1.0            |
| φ25.4     | 1/2H     | 1.0            | 1/2H     | 1.0            |
| φ28.6     | 1/2H     | 1.0            | 1/2H     | 1.0            |
| φ31.8     | 1/2H     | 1.2            | 1/2H     | 1.1            |
| φ38.1     | 1/2H     | 1.4            | 1/2H     | 1.4            |
| φ44.5     | 1/2H     | 1.6            | 1/2H     | 1.6            |

\* O: Soft (Annealed)  
H: Hard (Drawn)

## 1. Flaring tool

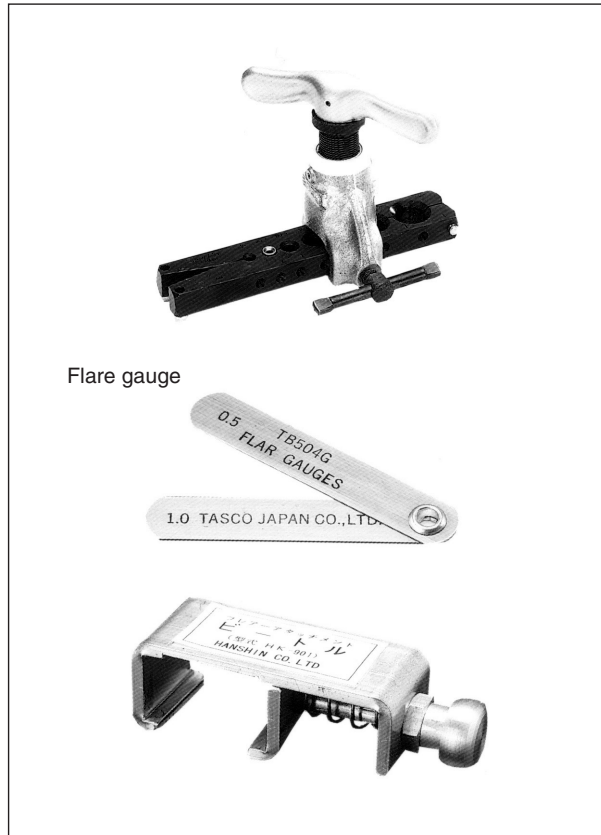

### ■ Specifications

- Dimension A

Unit:mm

| Nominal size | Tube O.D.<br>Do | A <sup>+0</sup> <sub>-0.4</sub> |                        |
|--------------|-----------------|---------------------------------|------------------------|
|              |                 | Class-2 (R-410A)                | Class-1 (Conventional) |
| 1/4          | 6.35            | 9.1                             | 9.0                    |
| 3/8          | 9.52            | 13.2                            | 13.0                   |
| 1/2          | 12.70           | 16.6                            | 16.2                   |
| 5/8          | 15.88           | 19.7                            | 19.4                   |
| 3/4          | 19.05           | 24.0                            | 23.3                   |

### ■ Differences

- Change of dimension A

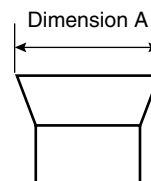

For class-1: R-407C  
For class-2: R-410A

Conventional flaring tools can be used when the work process is changed.  
(change of work process)

Previously, a pipe extension margin of 0 to 0.5mm was provided for flaring. For R-410A air conditioners, perform pipe flaring with a pipe extension margin of 1.0 to 1.5mm.  
(For clutch type only)

Conventional tool with pipe extension margin adjustment can be used.

**2. Torque wrench**

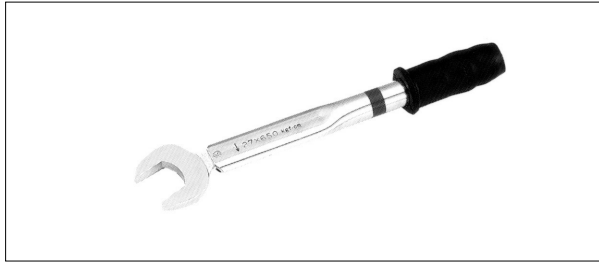

■ Specifications

- Dimension B Unit:mm

| Nominal size | Class-1 | Class-2 | Previous |
|--------------|---------|---------|----------|
| 1/2          | 24      | 26      | 24       |
| 5/8          | 27      | 29      | 27       |

No change in tightening torque  
 No change in pipes of other sizes

■ Differences

- Change of dimension B  
 Only 1/2", 5/8" are extended

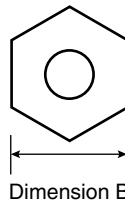

For class-1: R-407C  
 For class-2: R-410A

**3. Vacuum pump with check valve**

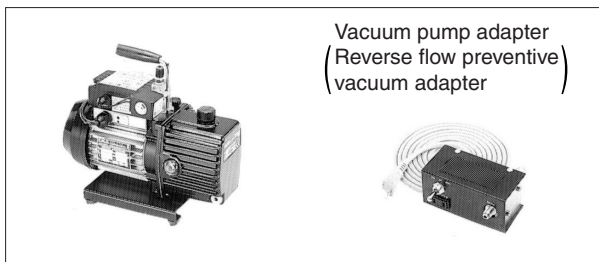

■ Specifications

- Discharge speed  
 50 l/min (50Hz)  
 60 l/min (60Hz)
- Suction port UNF7/16-20(1/4 Flare)  
 UNF1/2-20(5/16 Flare) with adapter
- Maximum degree of vacuum  
 Select a vacuum pump which is able to keep the vacuum degree of the system in excess of -14.6 psi (5 torr or 5000 micron or - 755 mmHg).

■ Differences

- Equipped with function to prevent reverse oil flow
- Previous vacuum pump can be used by installing adapter.

#### 4. Leak tester



- Specifications
  - Hydrogen detecting type, etc.
  - Applicable refrigerants  
R-410A, R-407C, R-404A, R-507A, R-134a, etc.
- Differences
  - Previous testers detected chlorine. Since HFCs do not contain chlorine, new tester detects hydrogen.

#### 5. Refrigerant oil



- Specifications
  - Contains synthetic oil, therefore it can be used for piping work of every refrigerant cycle.
  - Offers high rust resistance and stability over long period of time.
- Differences
  - Can be used for R-410A and R-22 units.

#### 6. Gauge manifold for R-410A

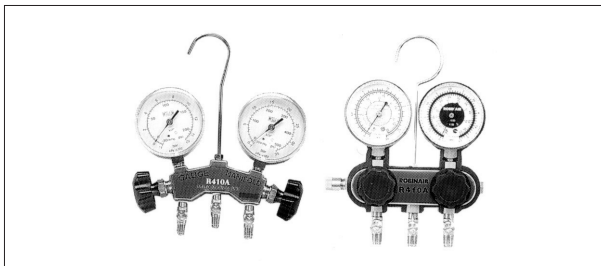

- Specifications
  - High pressure gauge  
15 to 770 psi (-76 cmHg to 53 kg/cm<sup>2</sup>)
  - Low pressure gauge  
15 to 550 psi (-76 cmHg to 38 kg/cm<sup>2</sup>)

- 1/4" → 5/16" (2min → 2.5min)
  - No oil is used in pressure test of gauges.  
→ For prevention of contamination
  - Temperature scale indicates the relationship between pressure and temperature in gas saturated state.
- Differences
- Change in pressure
  - Change in service port diameter

## 7. Charge hose for R-410A

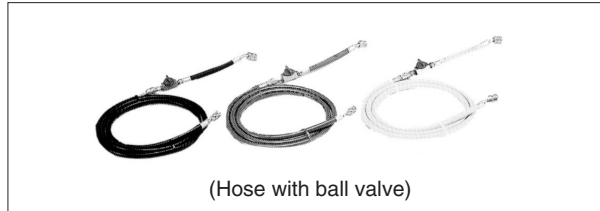

- Specifications
- Working pressure 737 psi (51.8 kg/cm<sup>2</sup>)
  - Rupture pressure 3685 psi (259 kg/cm<sup>2</sup>)
  - Available with and without hand-operate valve that prevents refrigerant from outflow.
- Differences
- Pressure proof hose
  - Change in service port diameter
  - Use of nylon coated material for HFC resistance

## 8. Weigher for refrigerant charge



- Specifications
- High accuracy  
TA101A (for 10-kg cylinder) = ± 2g  
TA101B (for 20-kg cylinder) = ± 5g
  - Equipped with pressure-resistant sight glass to check liquid refrigerant charging.
  - A manifold with separate ports for HFCs and previous refrigerants is equipped as standard accessories.
- Differences
- Measurement is based on weight to prevent change of mixing ratio during charging.

Regarding purchasing of service tools, please contact following address.  
Daikin U. S. Corporation (Dallas Office)  
1645 Wallace Dr, Ste 110 Carrollton, TX 75006  
"Tel : 1-972-245-1510 Fax : 1-972-245-1038"





## Symbols

“Under Centralized Control” Blinks (Repeats Single Blink) ..... 210

## A

A0 ..... 120  
 A1 ..... 121  
 A3 ..... 122  
 A6 ..... 124  
 A7 ..... 125  
 A9 ..... 127  
 AF ..... 129  
 AJ ..... 130  
 Abnormal Discharge Pipe Temperature ..... 146  
 Abnormal Outdoor Fan Motor Signal ..... 148  
 About Refrigerant R-410A ..... 246  
 Actuation of High Pressure Switch ..... 136  
 Actuation of Low Pressure Sensor ..... 137  
 Address Duplication of Central  
   Remote Controller ..... 188  
 Address Duplication, Improper Setting ..... 199, 207  
 Air Flow Direction Setting ..... 75  
 Applicable range of Field setting ..... 73

## B

Basic Control ..... 33

## C

C4 ..... 131  
 C5 ..... 132  
 C9 ..... 133  
 CHECK OPERATION FUNCTION ..... 102  
 CJ ..... 134  
 Centralized Control Group No. Setting ..... 76  
 Check No. 12 ..... 215  
 Check No. 13 ..... 215  
 Check No. 8 ..... 214  
 Check No. 9 ..... 214  
 Check Operation ..... 65  
 Check Operation not executed ..... 177  
 Compressor Motor Lock ..... 139  
 Compressor Motor Overcurrent/Lock ..... 141  
 Compressor PI Control ..... 34  
 Connectable Indoor Unit ..... 4  
 Connectable Indoor Units Number and Capacity ..... 4  
 Contents of Control Modes ..... 79  
 Cool/Heat Mode Switching ..... 89  
 Cooling Operation Fan Control ..... 39  
 Current Sensor Malfunction ..... 151

## D

Defrosting Operation ..... 43  
 Demand Operation ..... 57  
 Diode Module ..... 243  
 Discharge Pipe Protection Control ..... 51  
 Display “Under Centralized Control” Blinks  
   (Repeats Double Blink) ..... 213  
 Drain Level above Limit ..... 129  
 Drain Pump Control ..... 58

## E

E1 ..... 135  
 E3 ..... 136  
 E4 ..... 137  
 E5 ..... 139  
 E6 ..... 141  
 E7 ..... 142  
 E9 ..... 144  
 Electrical and Functional Parts  
   Indoor Units ..... 231  
   Outdoor Unit ..... 230  
 Electronic Expansion Valve PI Control ..... 38  
 Electronic circuit ..... 242  
 Emergency Operation ..... 55  
 Error of External Protection Device ..... 120  
 Example of Connection ..... 237  
 External Appearance ..... 3

## F

F3 ..... 146  
 F6 ..... 147  
 Fan Motor (M1F) Lock, Overload ..... 124  
 Field Setting ..... 69  
 Field Setting from Outdoor Unit ..... 81  
 Freeze Prevention ..... 62  
 Functional Parts Layout  
   RXYQ72M, 96M ..... 26

## H

H7 ..... 148  
 H9 ..... 150  
 Heating Operation Prohibition ..... 57  
 High Pressure Protection Control ..... 49

## I

Improper Combination of Optional Controllers for  
   Centralized Control ..... 197, 205  
 Indoor Unit Capacity ..... 4  
 Inverter Compressor Abnormal ..... 162  
 Inverter Current Abnormal ..... 163

|  |          |  |                    |
|--|----------|--|--------------------|
| Inverter Over-Ripple Protection .....  | 168      | Malfunction of System, Refrigerant System Address<br>Undefined .....                           | 192                |
| Inverter P.C.Board .....   | 242      | Malfunction of Thermistor (R1T) for Outdoor Air ....   | 150                |
| Inverter Protection Control .....  | 52       | Malfunction of Thermistor (R1T) for Suction Air ....   | 133                |
| Inverter Start up Error .....  | 165      | Malfunction of Thermistor (R2T)<br>for Heat Exchanger .....                                    | 131                |
| <b>J</b>   |          | Malfunction of Thermistor (R2T)<br>for Suction Pipe .....                                      | 153                |
| J2 .....   | 151      | Malfunction of Thermistor (R3T) for Gas Pipes ....   | 132                |
| J3 .....   | 152      | Malfunction of Thermistor (R4T) for<br>Outdoor Unit Heat Exchanger Deicer .....                | 154                |
| J5 .....   | 153      | Malfunction of Thermostat Sensor in<br>Remote Controller .....                                 | 134                |
| J6 .....   | 154      | Malfunction of Transmission Between Central Remote<br>Controller and Indoor Unit .....         | 200                |
| J7 .....   | 155      | Malfunction of Transmission Between Centralized<br>Controller and Indoor Unit .....            | 189                |
| J8 .....   | 156      | Malfunction of Transmission Between<br>Indoor Units and Outdoor Units .....                    | 178                |
| J9 .....   | 157      | Malfunction of Transmission Between Indoor Units and<br>Outdoor Units in the Same System ..... | 184                |
| JA .....   | 158      | Malfunction of Transmission Between Inverter and<br>Control PC Board .....                     | 166                |
| JC .....   | 160      | Malfunction of Transmission Between Main and Sub<br>Remote Controllers .....                   | 183                |
| <b>L</b>   |          | Malfunction of Transmission Between Optional<br>Controllers for Centralized Control .....      | 195, 203           |
| L4 .....   | 161      | Malfunction of Transmission Between<br>Outdoor Units .....                                     | 181                |
| L5 .....   | 162      | Malfunction of Transmission Between Remote<br>Controller and Indoor Unit .....                 | 180                |
| L8 .....   | 163      | <b>O</b>   |                    |
| L9 .....   | 165      | Oil Return Operation .....   | 41                 |
| LC .....   | 166      | Operation Lamp Blinks .....  | 208                |
| Low Noise Operation and Demand Operation .....   | 94       | Operation Mode .....   | 32                 |
| Low Pressure Drop Due to Refrigerant Shortage or<br>Electronic Expansion Valve Failure ..... | 172      | Operation When Power is Turned On .....  | 67                 |
| Low Pressure Protection Control .....  | 50       | Option List .....  | 235                |
| <b>M</b>   |          | Other Control .....  | 54                 |
| M1 .....   | 194, 202 | Outdoor Unit PC Board Layout .....   | 68                 |
| M8 .....   | 195, 203 | Outdoor Unit Rotation .....  | 54                 |
| MA .....   | 197, 205 | <b>P</b>   |                    |
| MC .....   | 199, 207 | P1 .....   | 168                |
| Malfunction code indication by outdoor<br>unit PCB .....                                     | 118      | P4 .....   | 170                |
| Malfunction of Capacity Determination Device .....   | 130      | PC Board Defect .....  | 121, 135, 194, 202 |
| Malfunction of Discharge Pipe Pressure Sensor ....   | 158      | PJ .....   | 171                |
| Malfunction of Discharge Pipe Thermistor<br>(R31~33T) .....                                  | 152      | Power Supply Insufficient or Instantaneous<br>Failure .....                                    | 175                |
| Malfunction of Drain Level Control<br>System (S1L) .....                                     | 122      | Power Transistor IGBT (On Inverter PC Board) ....  | 243                |
| Malfunction of Inverter Radiating Fin<br>Temperature Rise .....                              | 161      | Precautions for New Refrigerant (R-410A) .....   | 246                |
| Malfunction of Inverter Radiating Fin<br>Temperature Rise Sensor .....                       | 170      | Pressure Equalization prior to Startup .....   | 48                 |
| Malfunction of Moving Part of Electronic Expansion<br>Valve (20E) .....                      | 127      | Pressure Sensor .....  | 241                |
| Malfunction of Moving Part of Electronic Expansion<br>Valve (Y1E, Y2E) .....                 | 144      | Protection Control .....   | 49                 |
| Malfunction of Outdoor Unit Fan Motor .....  | 142      | Pump-down Residual Operation .....   | 44                 |
| Malfunction of Receiver Outlet Liquid Pipe<br>Thermistor (R6T) .....                         | 155      |  |                    |
| Malfunction of Sub-Cooling Gas Pipe<br>Thermistor (R5T) .....                                | 157      |  |                    |
| Malfunction of Suction Pipe Pressure Sensor .....  | 160      |  |                    |
| Malfunction of Swing Flap Motor (MA) .....   | 125      |  |                    |

|  |     |                      |          |
|--|-----|----------------------|----------|
| <b>R</b>   |     | <b>U</b>             |          |
| Refrigerant Additional Charging Operation .....      | 100 | U0 .....             | 172      |
| Refrigerant Circuit                                  |     | U1 .....             | 174      |
| RXYQ72M, 96M .....                                   | 24  | U2 .....             | 175      |
| Refrigerant Flow for Each Operation Mode             |     | U3 .....             | 177      |
| RXYQ72M, 96M .....                                   | 27  | U4 .....             | 178      |
| Refrigerant Overcharged .....                        | 147 | U5 .....             | 180      |
| Remote Controller Self-Diagnosis Function .....      | 115 | U7 .....             | 181      |
| Remote Controller's Inspection /                     |     | U8 .....             | 183      |
| Test Operation Button .....                          | 112 | U9 .....             | 184      |
| Replacement Procedure for INV Compressor,            |     | UA .....             | 186      |
| VRV .....  | 218 | UC .....             | 188      |
| Replacing The Inverter's Power Transistors and Diode |     | UE .....             | 189, 200 |
| Modules .....  | 242 | UF .....             | 191      |
| Restart Standby .....                                | 45  | UH .....             | 192      |
| Reverse Phase, Open Phase .....                      | 174 |                      |          |
| <b>S</b>   |     | <b>V</b>             |          |
| STD Compressor Overload Protection .....             | 53  | Vacuuming Mode ..... | 102      |
| Service Mode   |     |                      |          |
| How to Enter .....                                   | 113 |                      |          |
| Mode No .....  | 114 |                      |          |
| Operation Method .....                               | 113 |                      |          |
| Remote controller display example .....              | 114 |                      |          |
| Service Tools .....                                  | 248 |                      |          |
| Setting Contents and Code No.– VRV Unit .....        | 72  |                      |          |
| Setting Modes  |     |                      |          |
| Auto Restart after Power Failure Reset .....         | 74  |                      |          |
| Fan Speed Changeover When Thermostat                 |     |                      |          |
| is OFF .....   | 74  |                      |          |
| Filter Sign Setting .....                            | 73  |                      |          |
| Ultra-Long-Life Filter Sign Setting .....            | 73  |                      |          |
| Setting by pushbutton switches .....                 | 82  |                      |          |
| Setting of Air Flow Direction Adjustment Range ..... | 75  |                      |          |
| Special Control .....                                | 40  |                      |          |
| Specifications .....                                 | 6   |                      |          |
| Indoor Units .....                                   | 11  |                      |          |
| Outdoor Units .....                                  | 6   |                      |          |
| Startup Control .....                                | 40  |                      |          |
| Stopping Operation .....                             | 46  |                      |          |
| System is not Set yet .....                          | 191 |                      |          |
| <b>T</b>   |     | <b>Z</b>             |          |
| Test Operation                                       |     | dip switches .....   | 81       |
| Procedure and Outline .....                          | 64  |                      |          |
| Thermistor Resistance / Temperature                  |     |                      |          |
| Characteristics .....                                | 239 |                      |          |
| Thermostat Sensor in Remote Controller .....         | 60  |                      |          |
| Troubleshooting                                      |     |                      |          |
| (OP: Central Remote Controller) .....                | 194 |                      |          |
| Troubleshooting                                      |     |                      |          |
| (OP: Schedule Timer) .....                           | 200 |                      |          |
| Troubleshooting                                      |     |                      |          |
| (OP: Unified ON/OFF Controller) .....                | 208 |                      |          |
| Troubleshooting by Remote Controller .....           | 108 |                      |          |



# Drawings & Flow Charts

|   |          |  |
|---|----------|--|
| <b>A</b>  |          |  |
| Abnormal Discharge Pipe Temperature.....  | 146      |  |
| Abnormal Outdoor Fan Motor Signal .....   | 148      |  |
| Actuation of High Pressure Switch.....  | 136      |  |
| Actuation of Low Pressure Sensor.....   | 137      |  |
| Additional refrigerant charge total flow.....   | 100      |  |
| Address Duplication of Central<br>Remote Controller.....  | 188      |  |
| Address Duplication, Improper Setting.....  | 199, 207 |  |
| <b>B</b>  |          |  |
| BRC4C Type.....   | 77       |  |
| BRC7C Type.....   | 77       |  |
| BRC7E Type.....   | 77       |  |
| <b>C</b>  |          |  |
| Centralized Control Group No. Setting<br>BRC1C Type .....   | 76       |  |
| Group No. Setting Example.....  | 78       |  |
| Charge hose for R-410A .....  | 252      |  |
| Check No. 12 .....  | 215      |  |
| Check No. 13 .....  | 215      |  |
| Check No. 8 .....   | 214      |  |
| Check No. 9 .....   | 214      |  |
| Check Operation .....   | 65       |  |
| Check Operation not executed.....   | 177      |  |
| Check Work Prior to Turn Power Supply on .....  | 64       |  |
| Compressor Motor Lock.....  | 139      |  |
| Compressor Motor Overcurrent/Lock.....  | 141      |  |
| Contents of Control Modes<br>How to Select Operation Mode.....  | 80       |  |
| Cool / Heat Mode Switching.....   | 89       |  |
| Current Sensor Malfunction .....  | 151      |  |
| <b>D</b>  |          |  |
| Display “Under Centralized Control” Blinks<br>(Repeats Double Blink) .....                                    | 213      |  |
| Display “Under Centralized Control” Blinks<br>(Repeats Single Blink) .....                                    | 210      |  |
| Display of sensor and address data.....   | 114      |  |
| Drain Level above Limit.....  | 129      |  |
| Drain Pump Control<br>When the Float Switch is Tripped and “AF” is<br>Displayed on the Remote Controller..... | 59       |  |
| When the Float Switch is Tripped During Heating<br>Operation.....   | 59       |  |
| When the Float Switch is Tripped While Cooling<br>OFF by Thermostat.....                                      | 58       |  |
| When the Float Switch is Tripped While the Cooling<br>Thermostat is ON.....                                   | 58       |  |
| <b>E</b>  |          |  |
| Error of External Protection Device .....   | 120      |  |
| Example of Connection.....  | 237      |  |
| External ON/OFF input .....   | 74       |  |
| <b>F</b>  |          |  |
| Fan Motor (M1F) Lock, Overload.....   | 124      |  |
| Faulty Field Setting after Replacing Main PC Board or<br>Faulty Combination of PC Board .....                 | 171      |  |
| Field Setting From Outdoor Unit<br>Mode changing procedure .....  | 82       |  |
| Field Setting from Outdoor Unit<br>Setting by dip switches.....   | 81       |  |
| Field Wiring<br>RXYQ72M, 96M .....  | 224      |  |
| Flaring tool .....  | 249      |  |
| Forced fan ON .....   | 114      |  |
| Freeze Prevention .....   | 62       |  |
| Functional Parts Layout<br>RXYQ72M, 96M .....   | 26       |  |
| <b>G</b>  |          |  |
| Gauge manifold for R-410A .....   | 251      |  |
| <b>H</b>  |          |  |
| How to Enter the Service Mode .....   | 113      |  |
| <b>I</b>  |          |  |
| Improper Combination of Indoor Units and Outdoor<br>Units/Indoor Units and Remote Controller.....             | 186      |  |
| Improper Combination of Optional Controllers for<br>Centralized Control.....                                  | 197, 205 |  |
| Individual setting.....   | 114      |  |
| Inverter Compressor Abnormal.....   | 162      |  |
| Inverter Current Abnormal .....   | 163      |  |
| Inverter Over-Ripple Protection .....   | 168      |  |
| Inverter Start up Error .....   | 165      |  |
| <b>L</b>  |          |  |
| Leak tester .....   | 251      |  |
| Low Pressure Drop Due to Refrigerant Shortage or<br>Electronic Expansion Valve Failure .....                  | 172      |  |
| <b>M</b>  |          |  |
| Malfunction hysteresis display .....  | 114      |  |
| Malfunction of Capacity Determination Device .....  | 130      |  |
| Malfunction of Discharge Pipe Pressure Sensor .....   | 158      |  |
| Malfunction of Discharge Pipe Thermistor<br>(R31~33T) .....   | 152      |  |
| Malfunction of Drain Level Control System<br>(S1L).....   | 122      |  |

|  |          |   |                    |
|--|----------|---|--------------------|
| Malfunction of Inverter Radiating Fin Temperature Rise .....                               | 161      | Operation of The Remote Controller's Inspection / Test Operation Button ..... | 112                |
| Malfunction of Inverter Radiating Fin Temperature Rise Sensor .....                        | 170      | Outdoor Unit PC Board Layout .....  | 68                 |
| Malfunction of Moving Part of Electronic Expansion Valve (20E) .....                       | 127      | <b>P</b>  |                    |
| Malfunction of Moving Part of Electronic Expansion Valve (Y1E, Y2E) .....                  | 144      | PC Board Defect.....  | 121, 135, 194, 202 |
| Malfunction of Oil Equalizing Pipe Thermistor (R7T) .....                                  | 156      | Piping Diagrams   |                    |
| Malfunction of Outdoor Unit Fan Motor .....  | 142      | FXFQ, FXSQ, FXMQ, FXHQ,   |                    |
| Malfunction of Receiver Outlet Liquid Pipe Thermistor (R6T) .....                          | 155      | FXAQ, FXLQ, FXNQ .....  | 221                |
| Malfunction of Sub-Cooling Gas Pipe Thermistor (R5T) .....                                 | 157      | RXYQ72M, 96M .....  | 220                |
| Malfunction of Suction Pipe Pressure Sensor .....  | 160      | Power Supply Insufficient or Instantaneous Failure.....                       | 175                |
| Malfunction of Swing Flap Motor (MA) .....   | 125      | Pressure Sensor .....   | 241                |
| Malfunction of System, Refrigerant System Address Undefined.....                           | 192      | <b>R</b>  |                    |
| Malfunction of Thermistor (R1T) for Outdoor Air .....                                      | 150      | Refrigerant Circuit   |                    |
| Malfunction of Thermistor (R1T) for Suction Air.....                                       | 133      | RXYQ72M, 96M .....  | 25                 |
| Malfunction of Thermistor (R2T) for Heat Exchanger .....                                   | 131      | Refrigerant Flow for Each Operation Mode                                      |                    |
| Malfunction of Thermistor (R2T) for Suction Pipe ...                                       | 153      | RXYQ72M, 96M .....  | 27                 |
| Malfunction of Thermistor (R3T) for Gas Pipes.....   | 132      | Refrigerant oil .....   | 251                |
| Malfunction of Thermistor (R4T) for Outdoor Unit Heat Exchanger Deicer .....               | 154      | Refrigerant Overcharged .....   | 147                |
| Malfunction of Thermostat Sensor in Remote Controller.....                                 | 134      | Remote Controller Self-Diagnosis Function.....                                | 115                |
| Malfunction of Transmission Between Central Remote Controller and Indoor Unit.....         | 200      | Replacement Procedure for INV Compressor, VRV .....                           | 218                |
| Malfunction of Transmission Between Centralized Controller and Indoor Unit.....            | 189      | Reverse Phase, Open Phase .....   | 174                |
| Malfunction of Transmission Between Indoor Units and Outdoor Units.....                    | 178      | <b>S</b>  |                    |
| Malfunction of Transmission Between Indoor Units and Outdoor Units in the Same System..... | 184      | Self-diagnosis by Wireless Remote Controller .....                            | 110                |
| Malfunction of Transmission Between Inverter and Control PC Board.....                     | 166      | Setting of Air Flow Direction Adjustment Range.....                           | 75                 |
| Malfunction of Transmission Between Main and Sub Remote Controllers.....                   | 183      | Setting of Demand Operation   |                    |
| Malfunction of Transmission Between Optional Controllers for Centralized Control.....      | 195, 203 | Image of operation in the case of A .....                                     | 97                 |
| Malfunction of Transmission Between Outdoor Units.....                                     | 181      | Image of operation in the case of A and B .....                               | 97                 |
| Malfunction of Transmission Between Remote Controller and Indoor Unit.....                 | 180      | Image of operation in the case of B .....                                     | 97                 |
| Method of Replacing The Inverter's Power Transistors and Diode Modules .....               | 242      | Setting of Low Noise Operation  |                    |
| Diode Module .....   | 243      | Image of operation in the case of A .....                                     | 95                 |
| Power Transistor IGBT (On Inverter PC Board).....  | 243      | Image of operation in the case of A and B .....                               | 95                 |
|  |          | Image of operation in the case of B .....                                     | 95                 |
| <b>O</b>   |          | Simplified Remote Controller .....  | 71                 |
| Operation Lamp Blinks.....   | 208      | System is not Set yet.....  | 191                |
|  |          | <b>T</b>  |                    |
|  |          | Test Operation  |                    |
|  |          | Procedure and Outline .....   | 64                 |
|  |          | Thermostat Sensor in Remote Controller  |                    |
|  |          | Cooling .....   | 60                 |
|  |          | Heating.....  | 61                 |
|  |          | Torque wrench.....  | 250                |
|  |          | Troubleshooting (OP: Central Remote Controller)...                            | 194                |
|  |          | Troubleshooting (OP: Schedule Timer) .....                                    | 200                |
|  |          | Troubleshooting (OP: Unified ON/OFF Controller).....                          | 208                |
|  |          | Turn Power on .....   | 64                 |
|  |          | <b>U</b>  |                    |
|  |          | Unit No. transfer.....  | 114                |

**W**

Weigher for refrigerant charge ..... 252  
Wired Remote Controller..... 69  
Wireless Remote Controller - Indoor Unit ..... 70  
Wiring Diagrams for Reference  
    Indoor Unit ..... 226  
    Outdoor Unit ..... 223





- Daikin Industries, Ltd.'s products are manufactured for export to numerous countries throughout the world. Daikin Industries, Ltd. does not have control over which products are exported to and used in a particular country. Prior to purchase, please therefore confirm with your local authorized importer, distributor and/or retailer whether this product conforms to the applicable standards, and is suitable for use, in the region where the product will be used. This statement does not purport to exclude, restrict or modify the application of any local legislation.
- Ask a qualified installer or contractor to install this product. Do not try to install the product yourself. Improper installation can result in water or refrigerant leakage, electrical shock, fire or explosion.
- Use only those parts and accessories supplied or specified by Daikin. Ask a qualified installer or contractor to install those parts and accessories. Use of unauthorized parts and accessories or improper installation of parts and accessories can result in water or refrigerant leakage, electrical shock, fire or explosion.
- Read the User's Manual carefully before using this product. The User's Manual provides important safety instructions and warnings. Be sure to follow these instructions and warnings.

If you have any inquiries, please contact your local importer, distributor and/or retailer.



© 2004 Daikin Industries, Limited.

Daikin®, Daikin AC™, Absolute Comfort™, VRV® and REFNET™ are trademarks pending or registered trademarks of Daikin Industries, Limited. All rights reserved. LowWorks® and LON® are registered trademarks of Echelon Corporation. BACnet® is a Data Communication Protocol for Building Automation and Control Networks, developed under the auspices of the American Society of Heating, Refrigerating and Air-Conditioning Engineers (ASHRAE).



JMI-0107



JQA-1452

**About ISO9001**

ISO 9001 is a plant certification system defined by the International Organization for Standardization (ISO) relating to quality assurance. ISO 9001 certification covers quality assurance aspects related to the "design, development, manufacture, installation, and supplementary service" of products manufactured at the plant.



EC99J2044



JQA-E-90108

**About ISO 14001**

ISO 14001 is the standard defined by the International Organization for Standardization (ISO) relating to environmental management systems. Our group has been acknowledged by an internationally accredited compliance organisation as having an appropriate programme of environmental protection procedures and activities to meet the requirements of ISO 14001.

Dealer

**DAIKIN AC (AMERICAS), INC.**

1645 Wallace Drive, Suite 110  
Carrollton, TX75006  
info@daikinac.com  
www.daikinac.com

©All rights reserved

● Specifications, designs and other content appearing in this brochure are current as of Oct. 2006 but subject to change without notice.